

Engineering Manual

WC™ Wall-Cassette

Mission Critical

Wall Mounted A/C's
(Single Circuit DX & CW)



Features & Benefits

- > 4 to 18 kW (1-5 Tons) Capacities
- > Precision Applications
 - Small Computer Rooms
 - Network Closets
 - IDF / MDF / AV Rooms
 - Equipment Control Rooms
- > Floor Space-Saving Wall Mounted
- > Split DX Air, Water & Glycol Cooled Plus Chilled Water Systems
- > Total Temp & Humidity Control
 - Free-Energy Hot Gas Reheat or Electric Reheat/Heat
 - Steam Humidifier
- > Microprocessor Controls & More

From
4 to 18 kW
Small Data Rooms

AboveAir™ MissionCritical™ wall cassette mounted air conditioners are the reliable environmental control solution to your precision cooling needs. Available in a wide variety of cooling methods and a full range of options, **AboveAir™** Air Conditioners are a step above!

- ☑ Space-Saving wall mounted design
- ☑ Total Temperature & Humidity Control
- ☑ Split Remote Outdoor or Indoor Condensing Units (DX - Air, Water or Glycol Cooled)
- ☑ EC Backward-Inclined Plug Fans
- ☑ Scroll Compressors (Fixed & 2-Speed)
- ☑ Flexible options and accessories
- ☑ R410a Refrigerant
- ☑ Energy efficient operation

Contents

Introduction	2
Model Configurations	2
Features and Benefits	3
Model Nomenclature	4
Guide Specifications	5-9
Cooling Capacity Data - DX Units	10-12
Cooling Capacity Data - CW Units	13
Physical Data - DX & CW Units	14-15
Heat Rejection Data - DX Units	16-17
Electrical Data	17-20
Dimensional Data	21-25
Other AboveAir Products	Back Cover!

DX - Air Cooled

WCH & XPU-()

DX - Air Cooled Split with Propeller Fan, Outdoor Remote Condensing Unit

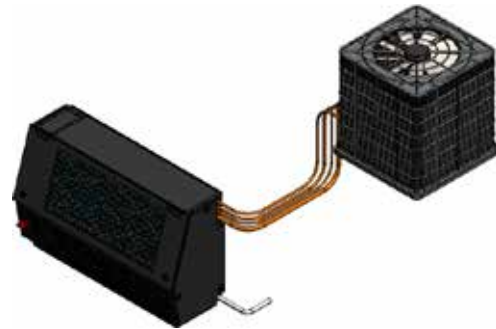

WCH with CCU or XCU -()

DX - Air Cooled Split with Centrifugal Blower, Indoor Remote Condensing Unit

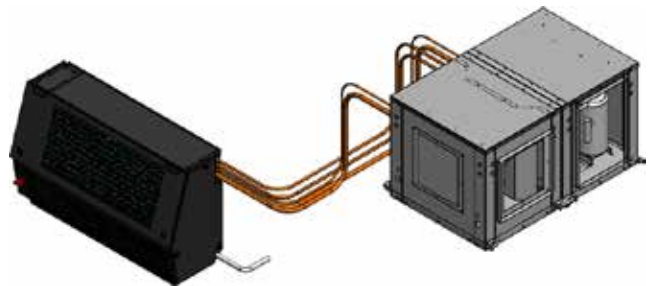

DX - Water/Glycol Cooled

WCH with CWU or CGU -()

DX - Water/Glycol Cooled Split with Indoor Condensing Unit

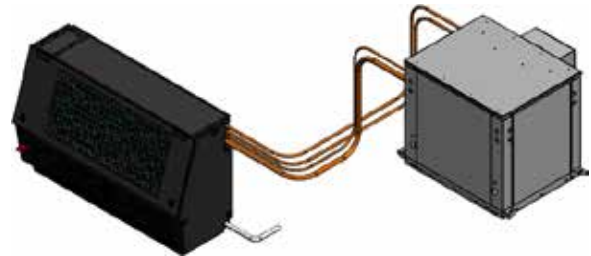

Chilled Water Systems

WCC-()

Chilled Water Air Handling Units



FEATURES & BENEFITS

AboveAir™ WC™ Wall-Cassette precision A/C's are designed to meet your unique application dependent requirements. Select from a wide range of options and configurations:



4-18kW (1-5 Tons)

Single Circuit Split DX &
Chilled Water Air Handlers

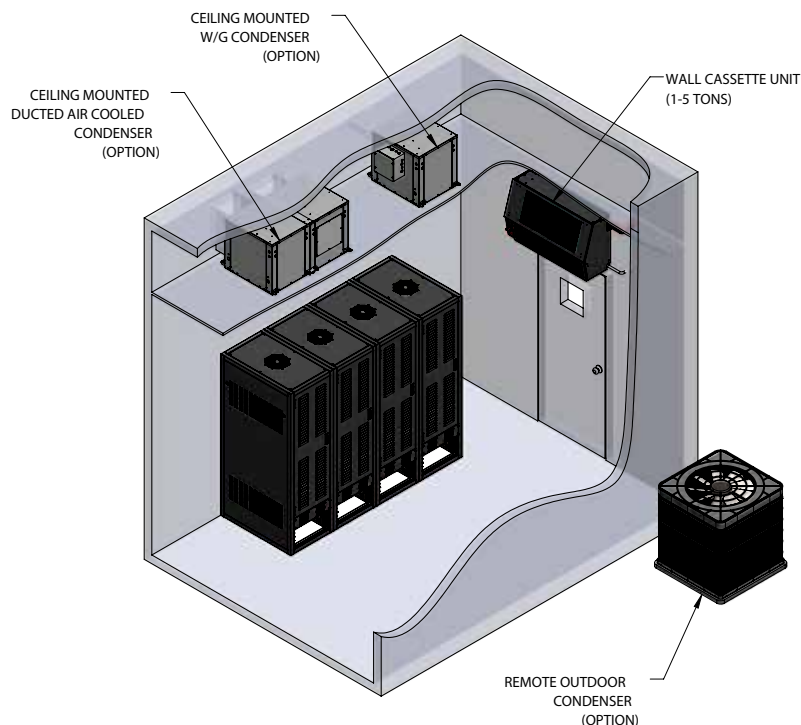

Variety of Standard & Optional Features



Standard & Optional Features:

- MC-2000, Advanced Microprocessor Controls
- Dehumidification Mode with Energy-Free Hot Gas Reheat or Electric Reheat/Heat
- Electrode Steam Canister Humidifier
- Scroll Compressor (Fixed or 2-Speed)
- EC Backward-Inclined Plug Fans
- High Efficiency Air Filtration
- Low Ambient Head Pressure Control
- 2 & 3-way 150 psig to 400 psig Water/Glycol Cooled Regulating Valves
- Hot Gas Bypass with Quench Valve
- Low Entering Condenser Water/Glycol Kit

Accessories:

- Condensate Pumps
- Main Power Electrical Disconnects
- Remote Water-Leak Detectors
- Condenser Water/Glycol Flow Switches
- Compressor Sound Jackets
- Condenser Water/Glycol Hose Kits
- Mounting Vibration Isolators
- Glycol Pump Packages & Drycoolers
- ... and more!



Features & Benefits

Model Nomenclature

WC Wall-Cassette Air Handling Unit Evaporators

Split, DX - Remote Condensing Units

WC	H	- 011	S	- 7	- HG	00	H	- EC	- B	- 0
a	b	- c	d	- e	- f	g	h	- i	- j	- k

XPU	- 011	S	- 7	- AA	- VF	1	- 2	B
a	- b	c	- d	- e	- f	g	- h	i

- a: WC** - MissionCritical Wall-Cassette
- b: C** - Chilled Water Air Handling Unit
H - DX, Split Air Handling Unit
- c: 004** = 4.0kW (1.0T); **005** = 5kW (1.5T); **007** = 7kW (2.0T);
009 = 9kW (2.5T); **011** = 11kW (3.0T); **012** = 12kW (3.5T);
014 = 14kW (4.0T); **018** = 18kW (5.0T)
- d: S** - Single Circuit DX System
X - Chilled Water System
- e: 1** - 208-230V / 1 Ph / 60 Hz
3 - 208-230V / 3 Ph / 60 Hz (w/ Electric Reheat/Heat Only)
7 - 277V / 1 Ph / 60 Hz
- f: 00** - No Hot Gas Reheat
HG - Hot Gas Reheat (2-POS, On/Off)
- g: 00** - No Unit Mtd Electric Heat
EO - Electric Heat Only, No Reheat
ER - Electric Reheat/Heat
- h: 0** - No Humidifier
H - Electrode Canister Steam Humidifier (requires side cabinet)
- i: EC** - EC = EC Plug Fan (Direct-Drive, Backward-Inclined Centrifugal Impeller, 0-10Vdc)
- j: B** - Cabinet Size ... A = 4-7kW (1-2T); B = 9-11kW (2.5-3T); or C = 12-18kW (3.5-5T)
- k: 0** - Not Applicable / No Compressor (*compressor located in remote condensing section*)
A - Chilled Water Valve - 2-Way, 300 psi (ON/OFF, 2-POS)
B - Chilled Water Valve - 3-Way, 300 psi (ON/OFF, 2-POS)
C - Chilled Water Valve - 2-Way, 300 psi (MOD, 0-10 VDC)
D - Chilled Water Valve - 3-Way, 300 psi (MOD, 0-10 VDC)
E - Chilled Water Valve by Others

- a: C/XCU** - DX, Split Indoor Ceiling Mtd Remote Air Cooled Centrifugal Blower Condensing Unit (Compr w/ CCU Cond Unit)
CGU - DX, Split Indoor Ceiling or Floor Mtd Remote Glycol Cooled Condensing Unit (Compr w/ CGU Cond Unit)
CWU - DX, Split Indoor Ceiling or Floor Mtd Remote Water Cooled Condensing Unit (Compr w/ CWU Cond Unit)
XPU - DX, Split Outdoor Mtd Remote Air Cooled Propeller Fan Condensing Unit (Compr w/ XPU Cond Unit)
- b: 004** = 4.0kW (1.0T); **005** = 5kW (1.5T); **007** = 7kW (2.0T);
009 = 9kW (2.5T); **011** = 11kW (3.0T); **012** = 12kW (3.5T);
014 = 14kW (4.0T); **018** = 18kW (5.0T)
- c: S** - Single Circuit DX System
- d: 1** - 208-230V / 1 Ph / 60 Hz
3 - 208-230V / 3 Ph / 60 Hz
4 - 460-480V / 3 Ph / 60 Hz
5 - 575V / 3 Ph / 60 Hz
7 - 277V / 1 Ph / 60 Hz
8 - 460-480V / 1 Ph / 60 Hz
- e: 00** - N/A
AA - Axial Fan w/ Std Motor
AB - DWDI FC BD Blower w/ ODP Motor
AD - Direct-Drive DWDI FC Blower w/ PSC Motor
EA - Axial Fan w/ ECM
EC - EC DD Backward-Inclined Impeller
ED - Direct-Drive DWDI FC Blower w/ ECM Motor
- f: 00** - Not Applicable
LD - Ducted, 90 Degree / Right-Angle, In-Front / Out Left-Side
MI - Ducted, Mirror-Image Same-Face Condenser Air Pattern
RD - Ducted, 90 Degree / Right-Angle, In-Rear / Out Right-Side
SF - Ducted, Same Face Condenser Air Pattern
ST - Ducted, Straight-Thru (ZST) Condenser Air Pattern
VF - Free Airflow, Vertical Discharge Air Pattern
- g: 0** - Not Applicable
1 - Slab or Wrap Around Type Condenser/Condensing Unit
S - SpotCool Condenser Section (4-11kW, 1-3T Units)
A - HK-A Condensing Unit Section (4-11kW, 1-3T Units)
B - HK-B Condensing Unit Section (9-18kW, 3.5-5T Units)
- h: 2** - Fixed Sd Scroll Compressor w/ Quench Hot Gas Bypass
3 - 2-Speed Scroll Compressor Option
- i: 0** - Not Applicable / No Head Pressure Control
1 - Low Amb ECM Variable Speed Fan Head Pressure Control
A - Low Amb Fan Cycling Head Pressure Control
B - Low Amb Variable Speed Fan Head Pressure Control
C - Low Amb Flooded Head Pressure Control
D - Water/Glycol Regulating Valve - 2-Way, 150 psig
E - Water/Glycol Regulating Valve - 2-Way, 350 psig
F - Water/Glycol Regulating Valve - 3-Way, 150 psig
G - Water/Glycol Regulating Valve - 3-Way, 350 psig

WCH & XPU-()

DX - Air Cooled Split with Propeller Fan, Outdoor Remote Condensing Unit

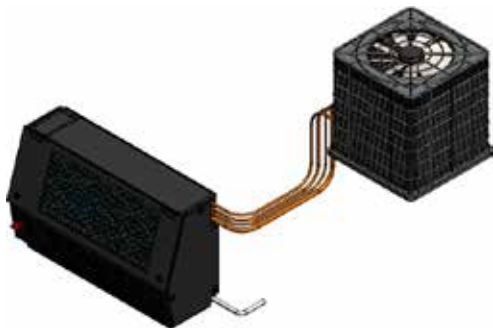

General

Summary



These specifications describe the requirements for a wall cassette mounted precision air conditioner. The system shall be designed to control space temperature and humidity.

The air conditioning manufacturer shall design and furnish all equipment in the quantities and configurations shown on the project plans and specifications.

The system shall be provided by AboveAir Technologies in Frederick, Maryland, USA. The system shall be listed by Intertek (ETL Semko), Inc. to conform with UL Std 1995 and be certified to CAN/CSA Std C22.2 No. 236 (Control No. 3091370). The system shall be NYC MEA229-06-E and Chicago Code Approved. The system model number shall be _____.

Design Requirements

The system shall be an AboveAir Technologies WC™ wall-cassette brand factory assembled and tested. The system shall be designed for indoor installation.

The system shall have a total cooling capacity of _____ BTU/H, and a sensible cooling capacity of _____ BTU/H, based on an entering air condition of _____ °F DB, and _____ °F WB, _____ % RH.

The evaporator section shall be designed for _____ Volt, _____ Phase, _____ Hertz main power supply. The remote condensing unit section (if applicable) shall be designed for _____ Volt, _____ Phase, _____ Hertz main power supply.

Submittals

Submittals shall be provided after manufacturer's receipt of a written purchase order and shall include: Detailed Performance and Electrical Data; Guide Specifications; and Dimensional Drawings.

Quality Assurance

The system shall be factory run tested prior to shipment. Testing shall include, but shall not be limited to: "HiPot" Test (2 times rated voltage plus 1000 volts, per UL 1995 testing requirements). The system shall be designed and manufactured according to world class quality standards.

Products

Standard Features

Cabinet

The cabinet chassis and access panels shall be powder-coat painted heavy gauge galvanized steel for decor matching and corrosion resistance. Cabinet access panels shall rest in recessed pockets designed for minimum air leakage. The cabinet and access panels shall be lined with 2 lb/ft² high density sound and thermal insulation and sealed with self-extinguishing gasketing conforming to NFPA 90A and 90B.

Component Access

The unit shall be easily serviceable through front, side & top access panels.

Electrical System

General:

The electrical system shall conform to National Electric Code (NEC) requirements according to UL 1995. The control circuit shall be a 24 VAC low voltage circuit.

The electrical system shall include, but not be limited to the following factory installed items: main power distribution block; grounding lug; 24 VAC control transformer; terminal connections; and motor controllers with start protection and circuit breakers for blower motors, compressors and each electric heater stage (if applicable).

Chilled Water Systems: (single point)

Self-Contained systems shall be designed for single point main power connection.

Split DX Systems: (separate power)

Split systems shall require separate main power supplies to the evaporator and condensing unit sections. The evaporator and condensing unit sections shall be electrically interlocked by a field wired 24 volt control signal.

Overflow Safety Float Switch:

The system shall be provided with a factory installed float type condensate overflow safety switch. The circuit shall be designed to shut down all system water producing operations in the event of an overflow condition.

Main Power, Disconnect

(WC_ Evap Section)



The indoor evaporator section shall be provided with a factory installed main power non-fused disconnect. The disconnect shall be NEMA rated for indoor or outdoor installation as required.

Air Distribution

EC Backward-Inclined Plug Fans



The evaporator blower assembly shall be either twin or triple backward-inclined direct-drive centrifugal impellers with energy saving variable speed EC (electronically communicated) motor. The blower shall be designed for _____ CFM @ _____ inches external static pressure (e.s.p.)

Air Filtration



The filter(s) shall be 1 inch thick pleated and Merv-8 efficiency rated (based on ASHRAE 52.2). The filter(s) shall be serviceable through the front hinged access panel without shutting down the system.

Direct Expansion Systems

DX - Evaporator Coil



The DX evaporator coil shall be constructed of copper tubes and aluminum fins. The system shall be designed for a draw-through air pattern for maximum heat transfer. Coil end-plates shall be hot dipped galvanized. The evapora-

tor coil shall be mounted in an insulated stainless steel condensate drain pan.

Scroll Compressors



Each compressor shall be the high efficiency, low sound Scroll type mounted on vibration isolators and located in a separate compartment out of the evaporator air stream to facilitate servicing while equipment is operating. Each compressor shall be complete with reversible positive oil pump, charging and service ports, internal spring isolation, and discharge gas vibration eliminator.

(Note: 2-Speed Scroll Compressors are optionally available from 5-18kW (1.5-5 Tons)!

DX - Refrigeration Circuit



Each refrigeration circuit shall be pre-piped with type "L" refrigerant copper tubing. The refrigeration system shall include but not be limited to: expansion valve with external equalizer and rapid bleed-through capacity. Features shall include filter dryer, sight glass, pressure fittings and high pressure/low pressure safety cutouts.

Cooling Configurations

DX - Air Cooled Split

(Split DX w/ Outdoor Condensing Unit)
WCH-() & XPU-()



The system shall be a split configuration with compact space-saving wall-cassette mounted precision DX air handling unit with outdoor DX air cooled propeller fan remote condensing unit. The compressor shall be located in the condensing unit. The condensing unit shall be sized for full heat of rejection at 95°F ambient and be capable of operation to ___ °F low ambient air temperature.

The system shall be refrigerant charged

and run tested at the factory prior to shipment. The evaporator and condensing unit sections shall ship separately with a dry-nitrogen charge ready for field refrigerant charging.

DX - Air Cooled Split

(Split DX w/ Indoor Condensing Unit)
WCH-() & CCU or XCU-()

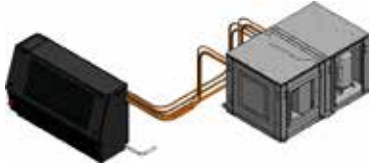

The system shall be a split configuration with compact space-saving wall-cassette mounted precision DX air handling unit with indoor DX - air cooled centrifugal blower remote condensing unit. The compressor shall be located in the condensing unit. The condensing unit shall be sized for full heat of rejection at 95°F ambient and be capable of operation to ___ °F low ambient air temperature.

The system shall factory tested prior to shipment. The air handling and condensing unit sections shall ship separately from the factory with a dry-nitrogen holding charge for field sweat (copper) connection and refrigerant charging.

DX - Water Cooled

(Split DX with Indoor Condensing Unit)
WCH-() & CWU-()

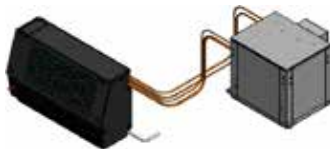

The system shall be a split configuration with compact space-saving wall-cassette mounted precision DX air handling unit with indoor DX - water cooled remote condensing unit. The compressor shall be located in the condensing unit. The system shall include a water cooled tube-in-tube coaxial condenser and factory installed head pressure controlling 2-way water regulating valve rated for 150 psi w.w.p. The water cooled condenser shall be designed to provide the total required system heat of rejection at 85°F entering water temperature and 95°F leaving water temperature.

The system shall factory tested prior to shipment. The air handling and condensing unit sections shall ship separately from the factory with a dry-nitrogen holding charge for field sweat (copper) connection and refrigerant charging.

(Note: 3-Way and High Pressure valves are

optionally available)

DX - Glycol Cooled

(Split DX with Indoor Condensing Unit)
WCH-() & CGU-()

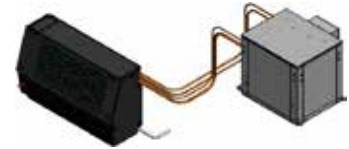

The system shall be a split configuration with compact space-saving wall-cassette mounted precision DX air handling unit with indoor DX - glycol cooled remote condensing unit. The compressor shall be located in the condensing unit. The system shall include a glycol cooled tube-in-tube coaxial condenser and factory installed head pressure controlling 2-way glycol regulating valve rated for 150 psi w.w.p. The condenser shall be designed to provide the total required system heat of rejection at 110°F entering glycol temperature and 120°F leaving glycol temperature based on 40% ethylene glycol solution. Source glycol shall be provided by a remote glycol drycooler source (see AboveAir Technologies' FluidCool™ drycoolers).

The system shall factory tested prior to shipment. The air handling and condensing unit sections shall ship separately from the factory with a dry-nitrogen holding charge for field sweat (copper) connection and refrigerant charging.

(Note: 3-Way and High Pressure valves are optionally available)

Glycol Pump Packages & Drycoolers

FC_-() / PA_-()



Glycol condenser source shall be provided by a FluidCool™ brand remote air cooled glycol drycooler and Pump-All™ brand pump package.

The glycol drycooler shall be the outdoor mounted propeller fan type complete with factory installed aquastat fan cycling controls, motor starters with overload protection and non-fused disconnect switch.

The glycol pump package shall be a (single or dual) pump package designed for outdoor installation complete with individual pump motor starters. Dual glycol pump packages shall be provided with manual lead-lag switch and field in-

Guide Specifications - WC™ Wall Cassette (4-18kW, 1-5 Tons)

stalled flow switch for automatic switchover to backup pump upon loss of flow.

An expansion tank and air purge fitting valve shall be factory provided for field installation.

The drycooler shall provide _____ BTUH total heat rejection at a flow rate of _____ GPM with _____ °F EGT and _____ °F LGT at _____ °F ambient air temperature. Each pump shall be _____ Hp and shall be sized to provide _____ GPM @ _____ Ft. w.g. total system head. The glycol solution shall be _____ % (ethylene or propylene) by volume.

The drycooler and pump package shall be designed for _____ Volt, _____ Phase, _____ Hertz main power supply.

(Note: See AboveAir Technologies' Fluid-Cool™ indoor & outdoor glycol drycooler and PumpAll™ glycol pump packages engineering manuals for more information.)

Chilled Water Systems WCC-()



The system shall be a compact space-saving wall-cassette mounted precision chilled water precision air conditioner.

The chilled water cooling coil shall be constructed of copper tubes and aluminum fins. Coil end-plates shall be hot dipped galvanized. The cooling coil shall be mounted in an insulated stainless steel condensate drain pan.

Chilled water flow shall be controlled by a factory installed 2-Way (2-POS, ON/OFF) control valve rated for a maximum 300 psig w.w.p.

(Note: 3-way, Modulating (0-10Vdc) & Higher Pressure valves are optionally available.)

Options

DX Air Cooled Condenser - Low Ambient Control

0°F Ambient - Fan Cycling (XPU Models)

Fan cycling controls shall be factory installed to the direct drive condenser fan to allow for low ambient operation to 0°F.

-20°F Ambient - Variable Spd Fan

(CCU, XCU & XPU Models)

Variable fan speed head pressure controls (JCI P266 or Modulating EC) shall be factory installed to allow for low ambient operation to -20°F. Compressor cold start time delay relay and crankcase heater shall be factory installed with the -20°F low ambient control feature.

-30°F Flooded Condenser (All Air Cooled Condensing Models)

A flooded condenser system shall be provided to allow for low ambient condenser operation to -30°F. The flooded system shall include a factory installed liquid refrigerant receiver and modulating head pressure control valve. Compressor cold start time delay relay and crankcase heater shall be factory installed with the -30°F low ambient control feature.

DX - Water / Glycol Cooled Head Pressure Control

DX - Water/Glycol Reg. Valves (Factory Installed!)



- 2-Way, 150 psig Reg. Valve
- 3-Way, 150 psig Reg. Valve
- 2-Way, 350 psig Reg. Valve
- 3-Way, 350 psig Reg. Valve
- 2-Way, 400 psig Reg. Valve
- 3-Way, 400 psig Reg. Valve

System head pressure shall be controlled by a factory provided _____-Way water / glycol regulating valve rated for _____ psig w.w.p.

Chilled Water Control Valves

Chilled Water Control Valves



Zone Valves, 2-Position ON/OFF:

- 2-Way, 300 psig (2-POS, ON/OFF, NC)
- 3-Way, 300 psig (2-POS, ON/OFF, NC)

Modulating Valves, 0-10Vdc:

- 2-Way, 300 psig (0-10Vdc, NC)
- 3-Way, 300 psig (0-10Vdc, NC)

A _____-way chilled water system control valve shall be factory installed within the air conditioning unit. The valve shall provide precision space cooling and/or dehumidification control. The valve shall be the 24 VAC, _____-Way, (2-Position ON/OFF or Modulating 0-10Vdc), normally closed type.

(Note: Higher pressure rated 400 psig control valves are also available. Please consult your local AboveAir representative for more information.)

Hot Gas Bypass Systems

Hot Gas Bypass To Suction Line with Quench Valve (3rd Line Not Required!)



Each refrigerant circuit of the Split DX system shall be provided with a factory installed hot gas bypass system to include: hot gas (discharge) bypass; desuperheating quench; and hot gas & quench solenoid valves. The hot gas bypass system shall be designed to supply hot gas and liquid refrigerant to the suction line as required to provide coil freeze-protection and capacity modulation under low load conditions. All hot gas bypass components shall be factory installed and shall not require additional field refrigerant lines on split DX systems.

Suction-Line Accumulator



Each refrigerant circuit shall be provided with a factory installed Suction-Line Accumulator to prevent liquid slugging of the compressor and excessive refrigerant dilution of the compressor oil during low load conditions. The accumulator shall return refrigerant and oil to the compressor at a sufficient rate to maintain both system operating efficiency and proper oil level. The accumulators shall be wrapped with 1/2" closed-cell neoprene insulation to prevent sweating.

CONTROL OPTIONS

MC-2000™, Advanced Temp/Humid Microprocessor Controller w/ Alarms & BMS Connection



The system shall be provided with a MC-2000™ advanced microprocessor based temperature and humidity controller with alarms.

Select Features/Benefits:

- 4x20 Character Liquid Crystal Alpha-numerical Display
- User Configurable
- Run-Time Hours
- Current Unit Mode Status
- Alarm Status
- Digital & Analog Inputs / Outputs
- Temperature Anticipation
- Remote Stop / Start Contact
- Summary Alarm Contact
- Automatic or Manual (selectable) Restart After Power Loss
- Sequential Load After Restart
- Recovery Delay
- Compressor Short Cycle Timers
- Cold Start Time Delay
- Security Password Access
- Self-Diagnostics
- Service Mode

Unit Status Display

The control system shall display current unit functions and room status (if applicable):

- Current Dry Bulb Temp Set Point
- Current Relative Humidity Set Point
- System ON/OFF
- Cooling
- Heating
- Humidifying
- Dehumidifying
- Reheating
- Actual Room DB Temperature
- Actual Room Relative Humidity

Alarm Conditions:

Alarm conditions activate an audible and visual indicator plus close a summary alarm dry contact connection. The control system shall alert to the following alarm conditions (optional, if applicable):

- | | |
|--------------------|----------------------|
| • High Temperature | • High Head Press |
| • Low Temperature | • Smoke Detection |
| • High Humidity | • Firestat |
| • Low Humidity | • Leak Detection |
| • Sensor Failure | • Loss of Power |
| • Summary Failure | • Dirty Filter |
| • Loss of Air Flow | • Loss of Fluid Flow |

Digital & Analog Control Inputs / Outputs:

The control system shall be capable of both digital (ON/OFF) and analog (proportional integral, PI) input and output control.

Select MC-2000 Options:

- Multi-Unit N+1 Sequencing
- BMS Communications Interface:
 - BACnet over MS/TP (RS485 Serial)
 - BACnet Over IP (Ethernet / EIA485)
 - ModBus RS485 Serial Connection

Heat / Reheat Options

Hot Gas Reheat



The system shall be provided with a hot gas reheat coil with 3-way heat reclaim control valve. The hot gas reheat coil shall provide free-energy space neutral leaving air temperature by offsetting the sensible cooling during dx dehumidification operation.

(Note: The maximum allowable refrigerant run for system with Hot Gas Reheat is 40 linear feet, including both horizontal and vertical refrigerant line components.)

Electric Reheat/Heat



An electric heating system shall be factory installed to provide Electric Reheat to offset sensible cooling during the dehumidification mode and to provide heating during heat mode.

Heater elements shall be the low-watt density finned-tubular (1-3T) or nichrome-wire (3.5-5T) type. The heater shall be complete with individual heater stage starter/contactors and overheat safeties. Systems incorporating factory installed electric heaters shall require only single point power to the main unit power distribution. The electric heat shall have a capacity of _____ BTU/H and a KW rating of ___ KW, controlled in ___ stages.

Humidification Options

Steam Humidification



An electrode steam canister type humidification system shall be factory installed within the air conditioning system. The humidifier shall be complete with disposable canister, steam distributor, fill and drain valve, air gap, automatic flush cycle, manual humidity output adjustment and field installed remote wall mounted humidistat. The humidifier shall have a maximum output capacity of _____ lbs/hr.

Accessories

Condensate Pump

(Factory or Field Installed Options)



A plenum rated condensate pump shall be factory provided and installed on the side of the indoor WC Wall Cassette air handling unit. The condensate pump shall be provided with dual internal float switches: one for pump operation initiation and the other for pump reservoir overflow safety.

(Note: Condensate Pumps for systems with Steam Humidifier Option shall ship loose for field installation.)

Main Power, Non-Fused Disconnect

(Remote Condenser/ing Section)



The remote condensing unit shall be factory provided with a main power non-fused disconnect for field installation. The disconnect shall be NEMA rated for indoor or outdoor installation as required.

Remote Water-Leak Detector



A remote water-leak detector shall be factory provided for field installation. The remote water-leak detector shall be wired to shut down all A/C unit water producing functions upon sensing a water leak.

(Note: Cable Type Remote Water Detectors are also optionally available.)

Flow Switch - Condenser Water



A factory installed flow switch shall shut-down / lockout compressor operation prior to a high refrigerant pressure switch alarm upon sensing a loss or low dx condenser water/glycol flow. The flow switch alarm shall be indicated both via MC-2000 microprocessor display and auxiliary dry-contact terminal connection.

Low Entering Condenser Water / Glycol Kit to 45°F EWT/EGT

A low enter condenser water/glycol kit shall be provided with liquid refrigerant receiver, compressor crankcase heater, insulated wrapped coaxial condenser and unit internal condenser water/glycol piping. The Low EWT/EGT kit shall allow for continued winter A/C operation when condenser source water/glycol drops below 65°F (down to 45°F).

Hose Kits - Automatic



Condenser water/glycol hose kits shall be factory provided. Each kit shall include the piping specialties necessary to ensure a proper installation: a Hays 2500 Series Mesurflo Automatic Flow Control Valve, two 36" flexible hoses, ball valves on the return and supply sides with P/T Ports, high flow "Y-ball" strainers for sizes 1/2"-2" and a manual air vent on the return. Hose materials shall be

the reinforced and bonded EPDM rubber type with a temperature rating of 32°F to 225°F and a working pressure of 400 psig. Minimum burst pressure shall be four (4) times the working pressure at maximum rated temperature. The hoses shall have stainless steel braid over an EPDM liner. The "Y-Ball" strainers shall have a stainless steel 20 mesh screen that is easily accessible for cleaning without disconnecting the hoses.

Mounting Vibration Isolators

Rubber/Cork Anti-Vibration Pads:



Each indoor ceiling or floor mounted condensing unit section shall be provided with a set of quantity four (4"x4"x7/8") Rubber/Cork Anti-Vibration Pad vibration mounting isolators.

Spring Mounting Isolators:



Each indoor ceiling or floor mounted condensing unit section shall be provided with a set of quantity four adjustable spring vibration mounting isolators with non-skid neoprene acoustical isolation pads. Isolators shall sized for the total distributive weight of the unit with a 1" deflection.

Compressor Sound Jacket



Each compressor shall be provided with a factory installed compressor sound jacket with a snap closure system for ease of removal and reinstallation. Sound jackets shall have a noise reduction coefficient (NRC) of 0.85 per ASTM (C423) and a sound transmission class/loss (STC) of 11 per ASTM E-90.

DX - Air Cooled, Cooling Capacities (4-18kW, 1-5 Tons)

Nominal Size	4kW (1.0 Ton)	5kW (1.5 Tons)	7kW (2.0 Tons)	9kW (2.5 Tons)
Model:	WCH w- XPU/CCU-004S-*	WCH w- XPU/CCU-005S-*	WCH w- XPU/CCU-007S-*	WCH w- XPU/CCU-009S-*
Cabinet Size:	A-Cabinet			B-Cabinet

DX - AIR COOLED
(4-9kW, 1-2.5 Tons)

Airflow Rate	CFM (CMH)	500 (850)	750 (1,274)	1,000 (1,699)	1,250 (2,124)
Net Cooling Capacity MBH (kW)					
85°F DB / 64.4°F WB, 52°F DP, (29.4°C DB / 18°C WB) 32% RH					
Total	MBH (kW)	17.1 (5.0)	18.3 (5.4)	23.7 (7.0)	31.3 (9.2)
Sensible	MBH (kW)	15.5 (4.6)	18.3 (5.4)	23.7 (7.0)	31.3 (9.2)
Eff. Rating w/ XPU	SCOP	2.61	2.58	2.65	3.00
Eff. Rating w/ CCU	SCOP	2.49	2.42	2.49	2.62
75°F DB / 62.5°F WB, 55.1°F DP, (23.9°C DB / 16.9°C WB) 50% RH					
Total	MBH (kW)	16.2 (4.8)	17.3 (5.1)	22.7 (6.6)	28.8 (8.4)
Sensible	MBH (kW)	11.8 (3.5)	13.8 (4.0)	17.6 (5.2)	25.4 (7.5)
75°F DB / 61°F WB, 52°F DP, (23.9°C DB / 16.1°C WB) 44.6% RH					
Total	MBH (kW)	15.8 (4.6)	16.8 (4.9)	22.1 (6.5)	28.3 (8.3)
Sensible	MBH (kW)	12.4 (3.6)	14.7 (4.3)	18.8 (5.5)	28.3 (8.3)
72°F DB / 60°F WB, 52°F DP, (22.2°C DB / 15.6°C WB) 50% RH					
Total	MBH (kW)	15.4 (4.5)	16.4 (4.8)	21.6 (6.3)	27.4 (8.0)
Sensible	MBH (kW)	11.6 (3.4)	13.5 (4.0)	17.2 (5.1)	25.0 (7.3)

Nominal Size	11kW (3.0 Tons)	12kW (3.5 Tons)	14kW (4.0 Tons)	18kW (5.0 Tons)
Model:	WCH w- XPU/CCU-011S-*	WCH w- XPU/XCU-012S-*	WCH w- XPU/XCU-014S-*	WCH w- XPU/XCU-035S-*
Cabinet Size:	B-Cabinet		C-Cabinet	

DX - AIR COOLED
(11-18kW, 3-5 Tons)

Airflow Rate	CFM (CMH)	1,500 (2,549)	1,650 (2,803)	1,800 (3,058)	2,200 (3,738)
Net Cooling Capacity MBH (kW)					
85°F DB / 64.4°F WB, 52°F DP, (29.4°C DB / 18°C WB) 32% RH					
Total	MBH (kW)	38.5 (11.3)	49.5 (14.5)	52.2 (15.3)	62.1 (18.2)
Sensible	MBH (kW)	38.5 (11.3)	49.4 (14.5)	52.2 (15.3)	62.1 (18.2)
Eff. Rating w/ XPU	SCOP	2.91	3.05	2.92	2.78
Eff. Rating w/ C/XCU	SCOP	2.48	2.60	2.73	2.54
75°F DB / 62.5°F WB, 55.1°F DP, (23.9°C DB / 16.9°C WB) 50% RH					
Total	MBH (kW)	35.9 (10.5)	47.3 (13.9)	49.8 (14.6)	59.7 (17.5)
Sensible	MBH (kW)	30.2 (8.9)	37.2 (10.9)	39.5 (11.6)	47.0 (13.8)
75°F DB / 61°F WB, 52°F DP, (23.9°C DB / 16.1°C WB) 44.6% RH					
Total	MBH (kW)	35.2 (10.3)	46.0 (13.5)	48.7 (14.3)	58.3 (17.1)
Sensible	MBH (kW)	33.5 (9.8)	39.6 (11.6)	42.6 (12.5)	51.0 (15.0)
72°F DB / 60°F WB, 52°F DP, (22.2°C DB / 15.6°C WB) 50% RH					
Total	MBH (kW)	34.3 (10.0)	45.0 (13.2)	47.5 (13.9)	56.8 (16.7)
Sensible	MBH (kW)	29.8 (8.7)	36.5 (10.7)	38.8 (11.4)	46.1 (13.5)

Split, DX - Air Cooled

WCH & XPU-()

DX - Air Cooled Split with Propeller Fan,
Outdoor Remote Condensing Unit

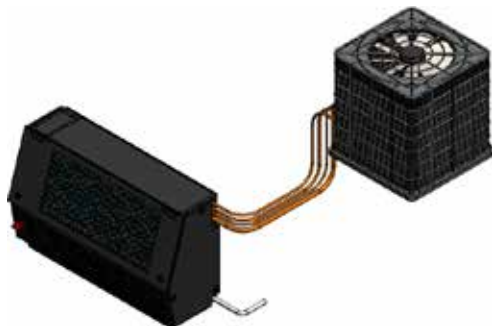

WCH with CCU or XCU -()

DX - Air Cooled Split with Centrifugal Blower,
Indoor Remote Condensing Unit

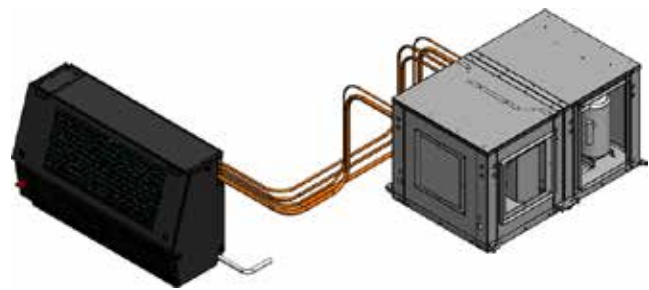

DX - Water Cooled, Cooling Capacities (4-18kW, 1-5 Tons)

DX - WATER COOLED
(4-9kW, 1-2.5 Tons)

Nominal Size		4kW (1.0 Ton)	5kW (1.5 Tons)	7kW (2.0 Tons)	9kW (2.5 Tons)
Model:		WCH w- CWU-004S-*	WCH w- CWU-005S-*	WCH w- CWU-007S-*	WCH w- CWU-009S-*
Cabinet Size:		A-Cabinet			B-Cabinet
Airflow Rate	CFM (CMH)	500 (850)	750 (1,274)	1,000 (1,699)	1,250 (2,124)
Net Cooling Capacity MBH (kW)					
85°F DB / 64.4°F WB, 52°F DP, (29.4°C DB / 18°C WB) 32% RH					
Total	MBH (kW)	17.9 (5.2)	19.4 (5.7)	25.2 (7.4)	32.6 (9.5)
Sensible	MBH (kW)	15.7 (4.6)	19.4 (5.7)	25.2 (7.4)	32.6 (9.5)
Efficiency Rating	SCOP	2.69	3.12	3.13	3.64
75°F DB / 62.5°F WB, 55.1°F DP, (23.9°C DB / 16.9°C WB) 50% RH					
Total	MBH (kW)	17.1 (5.0)	18.2 (5.3)	23.8 (7.0)	30.2 (8.8)
Sensible	MBH (kW)	12.2 (3.6)	14.2 (4.2)	18.2 (5.3)	25.7 (7.5)
75°F DB / 61°F WB, 52°F DP, (23.9°C DB / 16.1°C WB) 44.6% RH					
Total	MBH (kW)	16.6 (4.9)	17.8 (5.2)	23.3 (6.8)	29.6 (8.7)
Sensible	MBH (kW)	12.9 (3.8)	15.2 (4.5)	19.3 (5.7)	28.0 (8.2)
72°F DB / 60°F WB, 52°F DP, (22.2°C DB / 15.6°C WB) 50% RH					
Total	MBH (kW)	16.2 (4.8)	17.4 (5.1)	22.7 (6.7)	28.9 (8.5)
Sensible	MBH (kW)	12.0 (3.5)	13.9 (4.1)	17.8 (5.2)	25.4 (7.4)

DX - WATER COOLED
(11-18kW, 3-5 Tons)

Nominal Size		11kW (3.0 Tons)	12kW (3.5 Tons)	14kW (4.0 Tons)	18kW (5.0 Tons)
Model:		WCH w- CWU-011S-*	WCH w- CWU-012S-*	WCH w- CWU-014S-*	WCH w- CWU-018S-*
Cabinet Size:		B-Cabinet	C-Cabinet		
Airflow Rate	CFM (CMH)	1,500 (2,549)	1,650 (2,803)	1,800 (3,058)	2,200 (3,738)
Net Cooling Capacity MBH (kW)					
85°F DB / 64.4°F WB, 52°F DP, (29.4°C DB / 18°C WB) 32% RH					
Total	MBH (kW)	40.0 (11.7)	53.0 (15.5)	54.5 (16.0)	65.1 (19.1)
Sensible	MBH (kW)	40.0 (11.7)	53.0 (15.5)	54.5 (16.0)	65.1 (19.1)
Efficiency Rating	SCOP	3.38	3.28	3.28	3.18
75°F DB / 62.5°F WB, 55.1°F DP, (23.9°C DB / 16.9°C WB) 50% RH					
Total	MBH (kW)	37.8 (11.1)	49.8 (14.6)	52.2 (15.3)	62.7 (18.4)
Sensible	MBH (kW)	31.0 (9.1)	38.3 (11.2)	40.6 (11.9)	48.3 (14.2)
75°F DB / 61°F WB, 52°F DP, (23.9°C DB / 16.1°C WB) 44.6% RH					
Total	MBH (kW)	37.1 (10.9)	48.5 (14.2)	50.9 (14.9)	61.1 (17.9)
Sensible	MBH (kW)	34.5 (10.1)	40.8 (12.0)	43.3 (12.7)	51.5 (15.1)
72°F DB / 60°F WB, 52°F DP, (22.2°C DB / 15.6°C WB) 50% RH					
Total	MBH (kW)	36.0 (10.6)	47.4 (13.9)	49.8 (14.6)	59.7 (17.5)
Sensible	MBH (kW)	30.4 (8.9)	37.6 (11.0)	39.9 (11.7)	47.4 (13.9)

Split, DX - Water Cooled

WCH with CWU-()
DX - Water Cooled Split with Indoor Condensing Unit

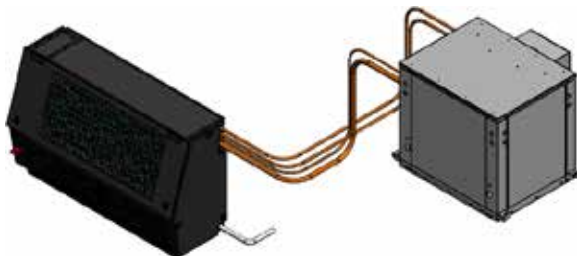

DX - Glycol Cooled, Cooling Capacities (4-18kW, 1-5 Tons)

Nominal Size	4kW (1.0 Ton)	5kW (1.5 Tons)	7kW (2.0 Tons)	9kW (2.5 Tons)
Model:	WCH w- CGU-004S-*	WCH w- CGU-005S-*	WCH w- CGU-007S-*	WCH w- CGU-009S-*
Cabinet Size:	A-Cabinet			B-Cabinet

DX - GLYCOL COOLED
(4-9kW, 1-2.5 Tons)

Airflow Rate	CFM (CMH)	N/A - Use 005 Data	750 (1,274)	1,000 (1,699)	1,250 (2,124)
Net Cooling Capacity MBH (kW)					
85°F DB / 64.4°F WB, 52°F DP, (29.4°C DB / 18°C WB) 32% RH					
Total	MBH (kW)	----	17.4 (5.1)	22.5 (6.6)	29.8 (8.7)
Sensible	MBH (kW)	----	17.4 (5.1)	22.5 (6.6)	29.8 (8.7)
Efficiency Rating	SCOP	----	2.10	2.04	2.32
75°F DB / 62.5°F WB, 55.1°F DP, (23.9°C DB / 16.9°C WB) 50% RH					
Total	MBH (kW)	----	16.2 (4.8)	21.4 (6.3)	27.1 (8.0)
Sensible	MBH (kW)	----	13.3 (3.9)	17.0 (5.0)	25.0 (7.3)
75°F DB / 61°F WB, 52°F DP, (23.9°C DB / 16.1°C WB) 44.6% RH					
Total	MBH (kW)	----	15.9 (4.6)	20.8 (6.1)	26.6 (7.8)
Sensible	MBH (kW)	----	14.4 (4.2)	18.2 (5.3)	26.6 (7.8)
72°F DB / 60°F WB, 52°F DP, (22.2°C DB / 15.6°C WB) 50% RH					
Total	MBH (kW)	----	15.4 (4.5)	20.3 (6.0)	25.8 (7.6)
Sensible	MBH (kW)	----	13.1 (3.8)	16.7 (4.9)	23.9 (7.0)

Nominal Size	11kW (3.0 Tons)	12kW (3.5 Tons)	14kW (4.0 Tons)	18kW (5.0 Tons)
Model:	WCH w- CGU-011S-*	WCH w- CGU-012S-*	WCH w- CGU-014S-*	WCH w- CGU-018S-*
Cabinet Size:	B-Cabinet	C-Cabinet		

DX - GLYCOL COOLED
(11-18kW, 3-5 Tons)

Airflow Rate	CFM (CMH)	1,500 (2,549)	1,650 (2,803)	1,800 (3,058)	2,200 (3,738)
Net Cooling Capacity MBH (kW)					
85°F DB / 64.4°F WB, 52°F DP, (29.4°C DB / 18°C WB) 32% RH					
Total	MBH (kW)	36.7 (10.8)	47.2 (13.8)	50.0 (14.6)	59.3 (17.4)
Sensible	MBH (kW)	36.7 (10.8)	47.2 (13.8)	50.0 (14.6)	59.3 (17.4)
Efficiency Rating	SCOP	2.15	2.15	2.14	2.04
75°F DB / 62.5°F WB, 55.1°F DP, (23.9°C DB / 16.9°C WB) 50% RH					
Total	MBH (kW)	34.0 (10.0)	44.6 (13.1)	47.1 (13.8)	56.3 (16.5)
Sensible	MBH (kW)	29.9 (8.8)	36.1 (10.6)	38.4 (11.3)	45.6 (13.4)
75°F DB / 61°F WB, 52°F DP, (23.9°C DB / 16.1°C WB) 44.6% RH					
Total	MBH (kW)	33.2 (9.7)	43.7 (12.8)	46.2 (13.5)	55.2 (16.2)
Sensible	MBH (kW)	33.1 (9.7)	39.3 (11.5)	42.3 (12.4)	50.7 (14.9)
72°F DB / 60°F WB, 52°F DP, (22.2°C DB / 15.6°C WB) 50% RH					
Total	MBH (kW)	32.4 (9.5)	42.4 (12.4)	44.9 (13.1)	53.6 (15.7)
Sensible	MBH (kW)	29.4 (8.6)	35.3 (10.3)	37.6 (11.0)	44.6 (13.1)

Split, DX - Glycol Cooled

WCH with CGU-()
DX - Glycol Cooled Split with Indoor Condensing Unit

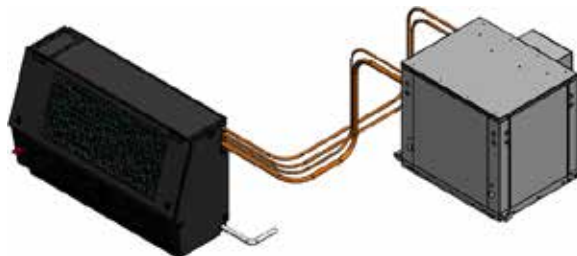

Chilled Water System, Cooling Capacities

Nominal Size	4kW (1.0 Ton)	5kW (1.5 Tons)	7kW (2.0 Tons)	9kW (2.5 Tons)
Model:	WCC-004S-*	WCC-005S-*	WCC-007S-*	WCC-009S-*
Cabinet Size:	A-Cabinet			B-Cabinet

CHILLED WATER SYSTEMS 45°F EWT 55°F LWT (4-9kW, 1-2.5 Tons)	Airflow Rate	CFM (CMH)	500 (850)	750 (1,274)	1,000 (1,699)	1,250 (2,124)	
	Net Cooling Capacity MBH (kW)						
	85°F DB / 64.4°F WB, 52°F DP, (29.4°C DB / 18°C WB) 32% RH						
	Total	MBH (kW)	16.9 (5.0)	23.0 (6.7)	28.2 (8.3)	43.2 (12.7)	
	Sensible	MBH (kW)	16.2 (4.7)	22.8 (6.7)	28.2 (8.3)	41.3 (12.1)	
	Flow Rate, (Coil PD)	GPM / FT WG	3.4 / 5.7	4.7 / 10.3	5.8 / 15.3	8.8 / 13.9	
	75°F DB / 62.5°F WB, 55.1°F DP, (23.9°C DB / 16.9°C WB) 50% RH						
	Total	MBH (kW)	13.5 (4.0)	18.0 (5.3)	21.6 (6.3)	34.6 (10.1)	
	Sensible	MBH (kW)	11.2 (3.3)	15.5 (4.5)	19.2 (5.6)	28.4 (8.3)	
	Flow Rate, (Coil PD)	GPM / FT WG	2.8 / 3.9	3.7 / 6.5	4.4 / 9.3	7.1 / 9.4	
	75°F DB / 61°F WB, 52°F DP, (23.9°C DB / 16.1°C WB) 44.6% RH						
	Total	MBH (kW)	12.2 (3.6)	16.5 (4.8)	20.0 (5.9)	31.4 (9.2)	
	Sensible	MBH (kW)	11.5 (3.4)	16.2 (4.7)	20.0 (5.9)	29.4 (8.6)	
	Flow Rate, (Coil PD)	GPM / FT WG	2.5 / 3.1	3.4 / 5.6	4.1 / 8.1	6.4 / 7.8	
	72°F DB / 60°F WB, 52°F DP, (22.2°C DB / 15.6°C WB) 50% RH						
	Total	MBH (kW)	10.5 (3.1)	14.5 (4.2)	17.5 (5.1)	27.8 (8.1)	
	Sensible	MBH (kW)	10.1 (3.0)	14.1 (4.1)	17.5 (5.1)	25.7 (7.5)	
	Flow Rate, (Coil PD)	GPM / FT WG	2.2 / 2.6	3.0 / 4.4	3.6 / 6.4	5.7 / 6.3	

VALVE DATA	Chilled Water Control Valve									
	Standard Valve	TX	2-Way (2-POS, ON/OFF) - Factory Installed							
	Valve Size, (Cv)	IN (NO)	1/2 (3.5)	1/2 (3.5)	3/4 (7.5)	3/4 (7.5)				
	Optional Valve	TX	3-Way (2-POS, ON/OFF), 2 or 3-Way Modulating (0-10 VDC) - Factory Installed							
	Chilled Water IN/OUT	OD IN	5/8	5/8	7/8	7/8				

Nominal Size	11kW (3.0 Tons)	12kW (3.5 Tons)	14kW (4.0 Tons)	18kW (5.0 Tons)
Model:	WCC-011S-*	WCC-012S-*	WCC-014S-*	WCC-018S-*
Cabinet Size:	B-Cabinet		C-Cabinet	

CHILLED WATER SYSTEMS 45°F EWT 55°F LWT (11-18kW, 3-5 Tons)	Airflow Rate	CFM (CMH)	1,500 (2,549)	1,650 (2,803)	1,800 (3,058)	2,200 (3,738)	
	Net Cooling Capacity MBH (kW)						
	85°F DB / 64.4°F WB, 52°F DP, (29.4°C DB / 18°C WB) 32% RH						
	Total	MBH (kW)	49.4 (14.5)	62.5 (18.3)	66.9 (19.6)	77.9 (22.8)	
	Sensible	MBH (kW)	48.0 (14.1)	58.2 (17.1)	62.8 (18.4)	74.3 (21.8)	
	Flow Rate, (Coil PD)	GPM / FT WG	10.1 / 17.9	12.7 / 8.2	13.7 / 9.4	16.0 / 12.5	
	75°F DB / 62.5°F WB, 55.1°F DP, (23.9°C DB / 16.9°C WB) 50% RH						
	Total	MBH (kW)	38.9 (11.4)	50.2 (14.7)	53.5 (15.7)	61.7 (18.1)	
	Sensible	MBH (kW)	32.6 (9.6)	40.3 (11.8)	43.3 (12.7)	50.8 (14.9)	
	Flow Rate, (Coil PD)	GPM / FT WG	8.0 / 11.7	10.2 / 5.4	10.9 / 6.2	12.8 / 8.3	
	75°F DB / 61°F WB, 52°F DP, (23.9°C DB / 16.1°C WB) 44.6% RH						
	Total	MBH (kW)	35.7 (10.5)	45.6 (13.4)	48.7 (14.3)	56.4 (16.5)	
	Sensible	MBH (kW)	34.0 (10.0)	41.6 (12.2)	44.8 (13.1)	52.8 (15.5)	
	Flow Rate, (Coil PD)	GPM / FT WG	7.4 / 10.1	9.3 / 4.6	10.0 / 5.2	11.7 / 7.0	
	72°F DB / 60°F WB, 52°F DP, (22.2°C DB / 15.6°C WB) 50% RH						
	Total	MBH (kW)	31.5 (9.2)	40.5 (11.9)	43.2 (12.7)	49.6 (14.5)	
	Sensible	MBH (kW)	29.6 (8.7)	36.4 (10.7)	39.1 (11.5)	45.9 (13.5)	
	Flow Rate, (Coil PD)	GPM / FT WG	6.5 / 8.0	8.3 / 3.7	8.9 / 4.2	10.3 / 5.5	

VALVE DATA	Chilled Water Control Valve									
	Standard Valve	TX	2-Way (2-POS, ON/OFF) - Factory Installed							
	Valve Size, (Cv)	IN (NO)	3/4 (7.5)	3/4 (7.5)	3/4 (7.5)	1 (8.0)				
	Optional Valve	TX	3-Way (2-POS, ON/OFF), 2 or 3-Way Modulating (0-10 VDC) - Factory Installed							
	Chilled Water IN/OUT	OD IN	7/8	7/8	7/8	1-1/8				

Physical Data - All Systems

Nominal Size		4kW (1.0 Ton)	5kW (1.5 Tons)	7kW (2.0 Tons)	9kW (2.5 Tons)
WC Model Size		004	005	007	009
Reheat / Heat - Capacity includes evaporator motor heat, (Optional)					
Electric Reheat / Heat - (Optional)					
Capacity	MBH (kW)	11,536 (3.38)	11,638 (3.41)	17,577 (5.15)	17,713 (5.19)
Stages	TXT	One	One	One	One
Hot Gas Reheat - (Optional - Maxium 40 Ft. Linear Interconnecting Refrigerant Piping Run!)					
Capacity	MBH (kW)	11.2 (3.3)	16.7 (4.9)	22.1 (6.5)	27.6 (8.1)
Control Valve	TXT	3-Way Diverting (2-POS, ON/OFF) - Factory Installed			
Humidification - Electrode Steam Canister Humidifier with Adjustable Output - (Optional)					
Steam Canister	lb/hr (kg/hr)	5 (2.3)	5 (2.3)	5 (2.3)	5 (2.3)
Power Input	kW	1.7	1.7	1.7	1.7
Evaporator Fan / Motor - Direct-Drive, Backward-Inclined EC Plug Fan Impeller (Variable Speed Adjustable for Balancing)					
Std Airflow Rate	CFM (CMH)	500 (850)	750 (1,274)	1,000 (1,699)	1,250 (2,124)
Std Blower Motor Each	HP (kW)	0.36 (0.266)	0.36 (0.266)	0.36 (0.266)	0.36 (0.266)
Type (Qty.)	TXT (NO)	EC-Plug (2)	EC-Plug (2)	EC-Plug (2)	EC-Plug (2)
Evaporator Coil - Aluminum Fin, Copper Tube					
DX Coil Rows / Face Area	NO / FT2 (m2)	2 / 2.33 (0.22)	2 / 2.33 (0.22)	2 / 2.33 (0.22)	3 / 3.17 (0.30)
CW Coil Rows / Face Area	NO / FT2 (m2)	3 / 2.33 (0.22)	3 / 2.33 (0.22)	3 / 2.33 (0.22)	4 / 3.17 (0.30)
Face Velocity	FPM (m/s)	215 (1.09)	322 (1.64)	429 (2.18)	394 (2.00)
Filters - 1 in (51 mm), Merv-8 Efficient					
Nom. Size	IN (mm)	13x31x1 (330x330x25)	13x31x1 (330x330x25)	13x31x1 (330x330x25)	13x39x1 (330x991x25)
Quantity	TXT	One	One	One	One
Effeciency Rating	TXT	Merv-8	Merv-8	Merv-8	Merv-8
Compressor - High Efficiency, Fixed Speed Scroll Standard					
Type (Qty.)	TXT (NO)	Scroll (1)	Scroll (1)	Scroll (1)	Scroll (1)
2-Speed or Digital Scroll	TXT	2-Spd Optional	2-Spd Optional	2-Spd Optional	2-Spd Optional
Refrigerant Charge - Base Unit w/o Receiver or Hot Gas Reheat Coil (consult factory for these values)					
DX - Air Cooled w/ XPU	lb (kg)	4.6 (2.1)	4.9 (2.2)	5.0 (2.3)	8.4 (3.8)
DX - Air Cooled w/ CCU	lb (kg)	8.5 (3.9)	8.2 (3.7)	8.2 (3.7)	8.9 (4)
DX - Water Cooled	lb (kg)	1.8 (0.8)	1.8 (0.8)	1.8 (0.8)	3.2 (1.5)
DX - Glycol Cooled	lb (kg)	1.8 (0.8)	1.8 (0.8)	1.8 (0.8)	3.2 (1.5)
Connection Sizes					
Cond. Drain w/ Unit Mtd Pump	OD IN	1/2	1/2	1/2	1/2
Cond. Drain w/o Unit Mtd Pump	PVC OD IN	3/4	3/4	3/4	3/4
Humidifier Inlet	OD IN	1/4	1/4	1/4	1/4
DX Refrig & W/G Condenser	TXT	See Page 16 for Split DX Refrigerant & Water/Glycol Condenser Piping Connections			
Chilled Water IN/OUT	OD IN	5/8	5/8	7/8	7/8
Dimensions - (Overall Nominal, For more information see detailed dimensional drawing section)					
WCH & WCC (HxWxD)	IN (mm)	24x42x14.8 (609.6x1066.8x375.9)	24x42x14.8 (609.6x1066.8x375.9)	24x42x14.8 (609.6x1066.8x375.9)	24x52x14.8 (609.6x1320.8x375.9)
Weight - (Approximate)					
WCH-*	LBS (kg)	140 (64)	140 (64)	140 (64)	155 (71)
WCC-*	LBS (kg)	140 (64)	140 (64)	140 (64)	155 (71)
Hot Gas Reheat Opt. Wt. Add	LBS (kg)	15 (7)	15 (7)	15 (7)	25 (12)
Electric RH/HT Opt. Wt. Add	LBS (kg)	10 (5)	10 (5)	10 (5)	10 (5)
Steam Humidifier Opt. Wt. Add	LBS (kg)	40 (18)	40 (18)	40 (18)	40 (18)
XPU-*	LBS (kg)	125 (57)	125 (57)	130 (59)	155 (70)
CCU-* or XCU-*	LBS (kg)	200 (91)	200 (91)	220 (100)	235 (107)
CWU-* or CGU-*	LBS (kg)	135 (61)	135 (61)	140 (63)	145 (66)
Shipping Pallet (add to above)	LBS (kg)	70 (32)	70 (32)	70 (32)	70 (32)

ALL SYSTEMS

Physical Data - All Systems

Nominal Size		11kW (3.0 Tons)	12kW (3.5 Tons)	14kW (4.0 Tons)	18kW (5.0 Tons)
WC Model Size		011	012	014	018
Reheat / Heat - Capacity includes evaporator motor heat, (Optional)					
Electric Reheat / Heat - (Optional)					
Capacity	MBH (kW)	18,089 (5.3)	35,017 (10.26)	35,188 (10.31)	35,905 (10.52)
Stages	TXT	One	One	One	One
Hot Gas Reheat - (Optional - Maxium 40 Ft. Linear Interconnecting Refrigerant Piping Run)					
Capacity	MBH (kW)	33 (9.7)	36.2 (10.6)	39.5 (11.6)	48.2 (14.1)
Control Valve	TXT				
Humidification - Electrode Steam Canister Humidifier with Adjustable Output - (Optional)					
Steam Canister	lb/hr (kg/hr)	5 (2.3)	5 (2.3)	5 (2.3)	5 (2.3)
Power Input	kW	1.7	1.7	1.7	1.7
Evaporator Fan / Motor - Direct-Drive, Backward-Inclined EC Plug Fan Impeller (Variable Speed Adjustable for Balancing)					
Std Airflow Rate	CFM (CMH)	1,500 (2,549)	1,650 (1,784)	1,800 (2,803)	2,200 (3,738)
Std Blower Motor	HP (kW)	0.36 (0.266)	0.36 (0.266)	0.36 (0.266)	0.36 (0.266)
Type (Qty.)	TXT (NO)	EC-Plug (2)	EC-Plug (3)	EC-Plug (3)	EC-Plug (3)
Evaporator Coil - Aluminum Fin, Copper Tube					
DX Coil Rows / Face Area	NO / FT2 (m2)	3 / 3.17 (0.30)	3 / 4.67 (0.43)	3 / 4.67 (0.43)	3 / 4.67 (0.43)
CW Coil Rows / Face Area	NO / FT2 (m2)	4 / 3.17 (0.30)	4 / 4.67 (0.43)	5 / 4.67 (0.43)	5 / 4.67 (0.43)
Face Velocity	FPM (m/s)	473 (2.40)	353 (1.79)	385 (1.96)	471 (2.39)
Filters - 1 in (51 mm), Merv-8 Efficient					
Nom. Size	IN (mm)	13x39x1 (330x991x25)	13x28Cx1 (330x330x25)	13x28Cx1 (330x330x25)	13x28Cx1 (330x330x25)
Quantity	TXT	One	One	Two	Two
Effeciency Rating	TXT	Merv-8	Merv-8	Merv-8	Merv-8
Compressor - High Efficiency, Fixed Speed Scroll Standard					
Type (Qty.)	TXT (NO)	Scroll (1)	Scroll (1)	Scroll (1)	Scroll (1)
2-Speed or Digital Scroll	TXT	2-Spd or Digital Opt	2-Spd or Digital Opt	2-Spd or Digital Opt	2-Spd or Digital Opt
Refrigerant Charge - Base Unit w/o Receiver or Hot Gas Reheat Coil (consult factory for these values)					
DX - Air Cooled w/ XPU	lb (kg)	8.6 (3.9)	11.0 (5)	12.2 (5.5)	14.4 (6.5)
DX - Air Cooled w/ CCU or XCU	lb (kg)	9.2 (4.2)	9.8 (4.4)	13.3 (6)	12.9 (5.9)
DX - Water Cooled	lb (kg)	3.1 (1.4)	4.6 (2.1)	4.5 (2.0)	4.6 (2.1)
DX - Glycol Cooled	lb (kg)	3.1 (1.4)	4.6 (2.1)	4.5 (2.0)	4.6 (2.1)
Connection Sizes					
Cond. Drain w/ Pump	OD IN	1/2	N/A	N/A	NA
Cond. Drain w/o Pump	PVC OD IN	3/4	3/4	3/4	3/4
Humidifier Inlet	OD IN	1/4	1/4	1/4	1/4
DX Refrig & W/G Condenser	TXT	See Page 17 for Split DX Refrigerant & Water/Glycol Condenser Piping Connections			
Chilled Water IN/OUT	OD IN	7/8	7/8	7/8	1-1/8
Dimensions - (Overall Nominal, For more information see detailed dimensonal drawing section)					
WCH & WCC (HxWxL)	IN (mm)	24x52x14.8 (609.6x1320.8x375.9)	24x70x14.8 (609.6x1778x375.9)	24x70x14.8 (609.6x1778x375.9)	24x70x14.8 (609.6x1778x375.9)
Weight - (Approximate)					
WCH-*	LBS (kg)	155 (71)	205 (93)	205 (93)	205 (93)
WCC-*	LBS (kg)	155 (71)	205 (93)	205 (93)	205 (93)
Hot Gas Reheat Opt. Wt. Add	LBS (kg)	25 (12)	30 (12)	30 (12)	30 (12)
Electric RH/HT Opt. Wt. Add	LBS (kg)	10 (5)	15 (7)	15 (7)	15 (7)
Steam Humidifier Opt. Wt. Add	LBS (kg)	40 (18)	40 (18)	40 (18)	40 (18)
XPU-*	LBS (kg)	160 (73)	180 (82)	185 (84)	200 (91)
CCU-* or XCU-*	LBS (kg)	250 (113)	475 (215)	485 (220)	495 (224)
CWU-* or CGU-*	LBS (kg)	150 (68)	315 (143)	320 (145)	325 (147)
Shipping Pallet (add to above)	LBS (kg)	70 (32)	70 (32)	70 (32)	70 (32)

ALL SYSTEMS

DX - Heat Rejection Data - WC Wall-Cassette (4-9kW, 1.0-2.5 Tons)

DX - Heat Rejection Data

Nominal Size	4kW (1.0 Ton)	5kW (1.5 Tons)	7kW (2.0 Tons)	9kW (2.5 Tons)
DX - Air Cooled Model	WCH w- XPU/CCU-004*	WCH w- XPU/CCU-005*	WCH w- XPU/CCU-007*	WCH w- XPU/CCU-009*

DX - AIR COOLED CONDENSING UNIT DATA - 95°F AMBIENT

Outdoor, Remote Propeller Fan Air Cooled Condensing Units - (XPU models)					
Remote Condensing Unit Model	TXT	XPU-004S	XPU-005S	XPU-007S	XPU-009S
Airflow Rate (208/277-1)	CFM (CMH)	1,600 (2,718)	1,881 (3,196)	2,614 (4,441)	3,167 (5,381)
Airflow Rate (208/460-3 & 460-1)	CFM (CMH)	N/A	N/A	2,218 (3,768)	3,700 (6,286)
E.S.P.	IN WG	Free Discharge	Free Discharge	Free Discharge	Free Discharge
Fan Motor	HP (kW)	1/6 (0.12)	1/6 (0.12)	1/4 (0.19)	1/4 (0.19)
Blower / Motor Qty.	NO	One	One	One	One
Blower Type	TXT	DD - Axial	DD - Axial	DD - Axial	DD - Axial
Rows / Face Area	NO / FT2 (m2)	1 / 8.40 (0.78)	1 / 9.90 (0.92)	1 / 9.80 (0.91)	1 / 17.25 (1.6)
Indoor, Remote Centrifugal Blower Air Cooled Condensing Unit Data - (CCU Models)					
Remote Condensing Unit Model	TXT	CCU-004S-_-A	CCU-005S-_-A	CCU-007S-_-A	CCU-009S-_-C
Airflow Rate	CFM	1,000	1,200	1,400	1,700
E.S.P.	IN WG	0.3	0.3	0.3	0.3
Std Blower Motor	HP (kW)	1/2 (0.37)	1/2 (0.37)	3/4 (0.56)	3/4 (0.56)
Blower / Motor Qty.	NO	One	One	One	One
Blower Type	TXT	DD - Centrifugal	DD - Centrifugal	DD - Centrifugal	DD - Centrifugal
Rows / Face Area	NO / FT2	4 / 2.0	4 / 2.0	4 / 2.5	4 / 2.5

AIR
COOLED
DX

DX - WATER COOLED CONDENSING UNIT DATA

Nominal Size	4kW (1.0 Ton)	5kW (1.5 Tons)	7kW (2.0 Tons)	9kW (2.5 Tons)
DX - Water Cooled Model	WCH w- CWU-004S*	WCH w- CWU-005S*	WCH w- CWU-007S*	WCH w- CWU-009S*

Water Cooled Condenser Data - 85°F EWT / 95°F LWT, 0% Glycol Solution (rated at 75°F DB/62.5°F WB EAT Cooling Performance)					
Total Heat of Rej.	MBH (kW)	20.3 (5.9)	21.5 (6.3)	28.4 (8.3)	34.7 (10.2)
Flow 85°F EWT	GPM (l/m)	4.8 (18.2)	5.1 (19.3)	6.7 (25.4)	8.0 (30.3)
Fluid Pressure Drop	FT WG (kPa)	9.8 (29.3)	11.1 (33.2)	15.7 (46.9)	8.4 (25.1)
Condenser Type	TXT	Coaxial	Coaxial	Coaxial	Coaxial
Water Reg. Valve	TXT	2-Way, 150 psig - factory installed, (3-way & High Pressure Valves are Optional)			
Valve Size, (Cv)	IN (NO)	1/2 (4.7)	1/2 (4.7)	3/4 (7.4)	3/4 (7.4)

WATER
COOLED
DX

DX - GLYCOL COOLED CONDENSING UNIT DATA

Nominal Size	4kW (1.0 Ton)	5kW (1.5 Tons)	7kW (2.0 Tons)	9kW (2.5 Tons)
DX - Glycol Cooled Model	WCH w- CGU-004S*	WCH w- CGU-005S*	WCH w- CGU-007S*	WCH w- CGU-009S*

Glycol Cooled Condenser Data - 110°F EWT / 120°F LWT, 40% Glycol Solution (rated at 75°F DB/62.5°F WB EAT Cooling Performance)					
Total Heat of Rej.	MBH (kW)	N/A - use 005 data	20.2 (5.9)	26.7 (7.8)	32.5 (9.5)
Flow 110°F EGT, 40% EG	GPM (l/m)	----	5.2 (19.7)	6.9 (26.1)	8.4 (31.8)
Fluid Pressure Drop	FT WG (kPa)	----	11.7 (35)	16.9 (50.5)	9.3 (27.8)
Condenser Type	TXT	----	Coaxial	Coaxial	Coaxial
Glycol Reg. Valve	TXT	2-Way, 150 psig - factory installed, (3-way & High Pressure Valves are Optional)			
Valve Size, (Cv)	IN (NO)	----	1/2 (4.7)	3/4 (7.4)	3/4 (7.4)

GLYCOL
COOLED
DX

Connection Data

DX - Split, DX - Air Handling Units - (WCH models)					
Liquid Line	OD IN	(1) 3/8	(1) 3/8	(1) 3/8	(1) 3/8
Suction Line	OD IN	(1) 3/4	(1) 3/4	(1) 3/4	(1) 3/4
Hot Gas Reheat Inlet Line (Optional)	OD IN	(1) 1/2	(1) 1/2	(1) 1/2	(1) 1/2
Hot Gas Reheat Outlet Line (Optional)	OD IN	(1) 1/2	(1) 1/2	(1) 1/2	(1) 1/2
DX - Outdoor, Axial Fan DX - Air Cooled, Remote Condensing Units - (XPU Models)					
Liquid Line	OD IN	(1) 3/8	(1) 3/8	(1) 3/8	(1) 3/8
Suction Line	OD IN	(1) 3/4	(1) 3/4	(1) 3/4	(1) 7/8
Hot Gas Reheat Inlet Line (Optional)	OD IN	(1) 1/2	(1) 1/2	(1) 1/2	(1) 1/2
Hot Gas Reheat Outlet Line (Optional)	OD IN	(1) 1/2	(1) 1/2	(1) 1/2	(1) 1/2
DX - Indoor, Centrifugal Blower DX - Air Cooled, Remote Condensing Units - (CCU & XCU models)					
Liquid Line	OD IN	(1) 3/8	(1) 3/8	(1) 3/8	(1) 3/8
Suction Line	OD IN	(1) 3/4	(1) 3/4	(1) 3/4	(1) 7/8
Hot Gas Reheat Inlet Line (Optional)	OD IN	(1) 1/2	(1) 1/2	(1) 1/2	(1) 1/2
Hot Gas Reheat Outlet Line (Optional)	OD IN	(1) 1/2	(1) 1/2	(1) 1/2	(1) 1/2
DX - Indoor, DX - Water / Glycol Cooled, Remote Condensing Units - (CWU & CGU models)					
Condenser Water/Glycol IN/OUT	OD IN	5/8	5/8	7/8	7/8
Liquid Line	OD IN	(1) 3/8	(1) 3/8	(1) 3/8	(1) 3/8
Suction Line	OD IN	(1) 3/4	(1) 3/4	(1) 3/4	(1) 7/8
Hot Gas Reheat Inlet Line (Optional)	OD IN	(1) 1/2	(1) 1/2	(1) 1/2	(1) 1/2
Hot Gas Reheat Outlet Line (Optional)	OD IN	(1) 1/2	(1) 1/2	(1) 1/2	(1) 1/2

ALL
DX
SYSTEMS

DX - Heat Rejection Data - WC Wall-Cassette (11-18kW, 3-5 Tons)

DX - Heat Rejection Data

Nominal Size		11kW (3.0 Tons)	12kW (3.5 Tons)	14kW (4.0 Tons)	18kW (5.0 Tons)
DX - Air Cooled Model		WCH w- XPU/CCU-011S*	WCH w- XPU/XCU-012S*	WCH w- XPU/XCU-014S*	WCH w- XPU/XCU-018S*

DX - AIR COOLED CONDENSING UNIT DATA - 95°F AMBIENT

Outdoor, Remote Propeller Fan Air Cooled Condensing Units - (XPU models)					
Remote Condensing Unit Model	TXT	XPU-011S	XPU-012S	XPU-014S	XPU-018S
Airflow Rate (208/277-1)	CFM (CMH)	3,167 (5,381)	1,881 (3,196)	2,614 (4,441)	3,167 (5,381)
Airflow Rate (208/460-3 & 460-1)	CFM (CMH)	3,700 (6,286)	N/A	2,218 (3,768)	3,700 (6,286)
E.S.P.	IN WG	Free Discharge	Free Discharge	Free Discharge	Free Discharge
Fan Motor	HP (kW)	1/4 (0.19)	1/4 (0.19)	1/4 (0.19)	1/4 (0.19)
Blower / Motor Qty.	NO	One	One	One	One
Blower Type	TXT	DD - Axial	DD - Axial	DD - Axial	DD - Axial
Rows / Face Area	NO / FT2 (m2)	1 / 17.25 (1.6)	1 / 9.90 (0.92)	1 / 9.80 (0.91)	1 / 17.25 (1.6)
Indoor, Remote Centrifugal Blower Air Cooled Condensing Unit Data - (CCU & XCU Models)					
Remote Condensing Unit Model	TXT	CCU-011S_-C	XCU-012S_-B	XCU-014S_-B	XCU-018S_-B
Airflow Rate	CFM	1,700	2,250	2,500	3,200
E.S.P.	IN WG	0.3	1.0	1.0	1.0
Std Blower Motor	HP	3/4 (0.56)	1-1/2 (1.12)	1-1/2 (1.12)	2 (1.49)
Blower / Motor Qty.	NO	One	One	One	One
Blower Type	TXT	DD - Centrifugal	BD - Centrifugal	BD - Centrifugal	BD - Centrifugal
Rows / Face Area	NO / FT2	4 / 2.5	4 / 6.5	4 / 6.5	4 / 6.5

DX - WATER COOLED CONDENSING UNIT DATA

Nominal Size		11kW (3.0 Tons)	12kW (3.5 Tons)	14kW (4.0 Tons)	18kW (5.0 Tons)
DX - Water Cooled Model		WCH w- CWU-011S*	WCH w- CWU-012S*	WCH w- CWU-014S*	WCH w- CWU-018S*

Water Cooled Condenser Data - 85°F EWT / 95°F LWT, 0% Glycol Solution (rated at 75°F DB/62.5°F WB EAT Cooling Performance)					
Total Heat of Rej.	MBH (kW)	43.8 (12.8)	57.4 (16.8)	60.7 (17.8)	72.7 (21.3)
Flow 85°F EWT	GPM (l/m)	10.1 (38.2)	13.5 (51.1)	14.1 (53.4)	17.2 (65.1)
Fluid Pressure Drop	FT WG (kPa)	13.6 (40.6)	10.0 (29.9)	11.1 (33.2)	14.8 (44.2)
Condenser Type	TXT	Coaxial	Coaxial	Coaxial	Coaxial
Water Reg. Valve	TXT	2-Way, 150 psig - factory installed, (3-way & High Pressure Valves are Optional)			
Valve Size, (Cv)	IN (NO)	3/4 (7.4)	3/4 (7.4)	3/4 (7.4)	1 (11.7)

DX - GLYCOL COOLED CONDENSING UNIT DATA

Nominal Size		11kW (3.0 Tons)	12kW (3.5 Tons)	14kW (4.0 Tons)	18kW (5.0 Tons)
DX - Glycol Cooled Model		WCH w- CGU-011S*	WCH w- CGU-012S*	WCH w- CGU-014S*	WCH w- CGU-018S*

Glycol Cooled Condenser Data - 110°F EWT / 120°F LWT, 40% Glycol Solution (rated at 75°F DB/62.5°F WB EAT Cooling Performance)					
Total Heat of Rej.	MBH (kW)	41.2 (12.1)	53.9 (15.8)	57.0 (16.7)	68.4 (20)
Flow 110°F EGT, 40% EG	GPM (l/m)	10.4 (39.4)	13.8 (52.2)	14.6 (55.3)	17.6 (66.6)
Fluid Pressure Drop	FT WG (kPa)	14.3 (42.7)	10.5 (31.4)	11.8 (35.3)	15.5 (46.3)
Condenser Type	TXT	Coaxial	Coaxial	Coaxial	Coaxial
Glycol Reg. Valve	TXT	2-Way, 150 psig - factory installed, (3-way & High Pressure Valves are Optional)			
Valve Size, (Cv)	IN (NO)	3/4 (7.4)	3/4 (7.4)	3/4 (7.4)	1 (11.7)

Connection Data

DX - Split, DX - Air Handling Units - (WCH models)					
Liquid Line	OD IN	(1) 3/8	(1) 3/8	(1) 3/8	(1) 1/2
Suction Line	OD IN	(1) 7/8	(1) 7/8	(1) 7/8	(1) 7/8
Hot Gas Reheat Inlet Line (Optional)	OD IN	(1) 1/2	(1) 5/8	(1) 5/8	(1) 5/8
Hot Gas Reheat Outlet Line (Optional)	OD IN	(1) 1/2	(1) 1/2	(1) 1/2	(1) 1/2
DX - Outdoor, Axial Fan DX - Air Cooled, Remote Condensing Units - (XPU Models)					
Liquid Line	OD IN	(1) 3/8	(1) 3/8	(1) 3/8	(1) 3/8
Suction Line	OD IN	(1) 7/8	(1) 7/8	(1) 7/8	(1) 7/8
Hot Gas Reheat Inlet Line (Optional)	OD IN	(1) 1/2	(1) 1/2	(1) 1/2	(1) 1/2
Hot Gas Reheat Outlet Line (Optional)	OD IN	(1) 1/2	(1) 5/8	(1) 5/8	(1) 5/8
DX - Indoor, Centrifugal Blower DX - Air Cooled, Remote Condensing Units - (CCU & XCU models)					
Liquid Line	OD IN	(1) 3/8	(1) 3/8	(1) 3/8	(1) 3/8
Suction Line	OD IN	(1) 7/8	(1) 7/8	(1) 7/8	(1) 7/8
Hot Gas Reheat Inlet Line (Optional)	OD IN	(1) 1/2	(1) 1/2	(1) 1/2	(1) 1/2
Hot Gas Reheat Outlet Line (Optional)	OD IN	(1) 1/2	(1) 5/8	(1) 5/8	(1) 5/8
DX - Indoor, DX - Water / Glycol Cooled, Remote Condensing Units - (CWU & CGU models)					
Condenser Water/Glycol IN/OUT	OD IN	7/8	5/8	7/8	1-1/8
Liquid Line	OD IN	(1) 3/8	(1) 3/8	(1) 3/8	(1) 3/8
Suction Line	OD IN	(1) 7/8	(1) 7/8	(1) 7/8	(1) 7/8
Hot Gas Reheat Inlet Line (Optional)	OD IN	(1) 1/2	(1) 1/2	(1) 1/2	(1) 1/2
Hot Gas Reheat Outlet Line (Optional)	OD IN	(1) 1/2	(1) 5/8	(1) 5/8	(1) 5/8

DX Heat Rejection Data

ELECTRICAL COMPONENT DATA - WC Series

Unit Size (Nominal)	WC Model	Main Power Supply	Evap Fan Motor (Nameplate)				Electric Reheat/Heat (Optional)		Steam Humidifier (Optional)		
			Qty.	FLA	HP (kW)	Type	KW	FLA	LB/HR (kg/hr)	FLA	KW
4-5kW (1-1.5 Tons)	WCH/C-004 & 005-1-*	208/1/60	2	1.3	0.36 (0.266)	EC	3.34	16.1	5 (2.3)	8.2	1.7
	WCH/C-004 & 005-7-*	277/1/60	2	1.0	0.36 (0.266)	EC	3.34	12.1	5 (2.3)	6.2	1.7
7-11kW (2-3 Tons)	WCH/C-007 thru 011-1-*	208/1/60	2	1.3	0.36 (0.266)	EC	5.01	24.1	5 (2.3)	8.2	1.7
	WCH/C-007 thru 011-7-*	277/1/60	2	1.0	0.36 (0.266)	EC	5.01	18.1	5 (2.3)	6.2	1.7
	WCH/C-007 thru 011-3-*	208/3/60	2	1.3	0.36 (0.266)	EC	5.01	13.9	5 (2.3)	8.2	1.7
	WCH/C-007 thru 011-4-*	460/3/60	See Note-2 Below								
12-18kW (3.5-5 Tons)	WCH/C-012 thru 018-1-*	208/1/60	3	1.0	0.36 (0.266)	EC	10.0	48.1	5 (2.3)	8.2	1.7
	WCH/C-012 thru 018-7-*	277/1/60	3	1.3	0.36 (0.266)	EC	10.0	36.1	5 (2.3)	6.2	1.7
	WCH/C-012 thru 018-3-*	208/3/60	3	1.0	0.36 (0.266)	EC	10.0	27.8	5 (2.3)	8.2	1.7
	WCH/C-012 thru 018-4-*	460/3/60	See Note-2 Below								

DX Split and Chilled Water - Air Handling Units (WCH & WCC-005 thru 018, 4-18kW)

MODEL	WCH & WCC-004 & 005		WCH & WCC-007, 009 & 011				WCH & WCC-012, 014 & 018			
Nominal Size	4-5kW (1-1.5 Tons)		7-11kW (2-3 Tons)				12-18kW (3.5-5 Tons)			
Power Supply	208/1/60	277/1/60	208/1/60	277/1/60	208/3/60	460/3/60 (Note-2)	208/1/60	277/1/60	208/3/60	460/3/60 (Note-2)
Cooling Only (or DX Cooling with Hot Gas Reheat)										
FLA	2.6	2.0	2.6	2.0	---	---	3.9	3.0	---	---
MCA	3.3	2.5	3.3	2.5	---	---	4.9	3.7	---	---
MOP	15	15	15	15	---	---	15	15	---	---
with Electric Reheat/Heat or Heat Only (No Humidifier)										
FLA	18.7	14.0	26.7	20.1	16.5	---	52.0	39.1	31.7	---
MCA	23.4	17.5	33.4	25.1	20.7	---	65.0	48.8	39.6	---
MOP	25	20	30	30	25	---	70	50	40	---
with Humidifier with or without DX Cooling with Hot Gas Reheat (No Electric Reheat/Heat)										
FLA	10.8	8.2	10.8	8.2	---	---	12.1	9.2	---	---
MCA	11.5	8.7	11.5	8.7	---	---	13.1	9.9	---	---
MOP	15	15	15	15	---	---	15	15	---	---
with Electric Heat or Electric Reheat/Heat & Humidifier										
FLA	26.9	20.2	34.9	26.3	24.7	---	60.2	45.3	39.9	---
MCA	31.6	23.7	41.6	31.3	28.9	---	73.2	55.0	47.8	---
MOP	35	25	45	35	30	---	80	60	50	---

Notes:

- 1) FLA = Full Load Amps; MCA = Min Circuit Amps; MOP = Max Overcurrent Protection (Max Fuse Size)
- 2) A field installed 460V to 208V Step-Down Main Power Transformer shall be required for 460/3/60 Main Power Supply Applications. Selection of the WC Series 277V system is recommended for these applications for ease of installation.

DX - AIR & WATER / GLYCOL COOLED, REMOTE CONDENSING UNITS

Unit Size (Nominal)	Condenser / Cond Unit Model	Main Power Supply	Type	Compressor (Fixed Speed)				Cond Fan Motor			Unit Nameplate Data			
				Qty.	RLA	LRA	Type	Qty.	HP (kW)	FLA	Type	FLA	MCA	MOP
4kW (1.0 Ton)	XPU-004S-1*	208/1/60	Outdoor Pad/Roof Mtd	1	9.0	48.0	Scroll	1	1/6 (0.12)	1.1	PSC	10.1	12.4	20
	XPU-004S-7*	277/1/60	Outdoor Pad/Roof Mtd	1	6.8	36.0	Scroll	1	1/6 (0.12)	0.8	PSC	7.6	9.3	15
	CCU-004S-1*	208/1/60	Indoor Ceiling Mtd	1	9.0	48.0	Scroll	1	1/2 (0.37)	4.0	PSC	13.0	15.3	20
	CCU-004S-7*	277/1/60	Indoor Ceiling Mtd	1	7.1	43.0	Scroll	1	1/2 (0.37)	2.2	PSC	9.3	11.1	15
	CWU/CGU-004S-1*	208/1/60	Indoor Ceiling Mtd	1	9.0	48.0	Scroll	---	---	---	---	9.0	11.3	20
	CWU/CGU-004S-7*	277/1/60	Indoor Ceiling Mtd	1	7.1	43.0	Scroll	---	---	---	---	7.1	8.9	15
5kW (1.5 Tons)	XPU-005S-1*	208/1/60	Outdoor Pad/Roof Mtd	1	9.0	48.0	Scroll	1	1/6 (0.12)	1.1	PSC	10.1	12.4	20
	XPU-005S-7*	277/1/60	Outdoor Pad/Roof Mtd	1	6.8	36.0	Scroll	1	1/6 (0.12)	0.8	PSC	7.6	9.3	15
	CCU-005S-1*	208/1/60	Indoor Ceiling Mtd	1	9.0	48.0	Scroll	1	1/2 (0.37)	4.0	PSC	13.0	15.3	20
	CCU-005S-7*	277/1/60	Indoor Ceiling Mtd	1	7.1	43.0	Scroll	1	1/2 (0.37)	2.2	PSC	9.3	11.1	15
	CWU/CGU-005S-1*	208/1/60	Indoor Ceiling Mtd	1	9.0	48.0	Scroll	---	---	---	---	9.0	11.3	20
	CWU/CGU-005S-7*	277/1/60	Indoor Ceiling Mtd	1	7.1	43.0	Scroll	---	---	---	---	7.1	8.9	15
7kW (2.0 Tons)	XPU-007S-1*	208/1/60	Outdoor Pad/Roof Mtd	1	10.9	62.9	Scroll	1	1/6 (0.12)	1.1	PSC	12.0	14.7	25
	XPU-007S-7*	277/1/60	Outdoor Pad/Roof Mtd	1	8.2	47.2	Scroll	1	1/6 (0.12)	0.8	PSC	9.0	11.1	15
	XPU-007S-3*	208/3/60	Outdoor Pad/Roof Mtd	1	7.7	55.4	Scroll	1	1/6 (0.12)	1.1	PSC	8.8	10.7	15
	XPU-007S-4*	460/3/60	Outdoor Pad/Roof Mtd	1	3.6	28.0	Scroll	1	1/4 (0.19)	1.0	PSC	4.6	5.5	15
	CCU-007S-1*	208/1/60	Indoor Ceiling Mtd	1	12.8	58.3	Scroll	1	3/4 (0.56)	5.4	PSC	18.2	21.4	30
	CCU-007S-7*	277/1/60	Indoor Ceiling Mtd	1	9.6	54.0	Scroll	1	3/4 (0.56)	3.9	PSC	13.5	15.9	25
	CCU-007S-3*	208/3/60	Indoor Ceiling Mtd	1	7.7	55.4	Scroll	1	3/4 (0.56)	5.4	PSC	13.1	15.0	20
	CCU-007S-4*	460/3/60	Indoor Ceiling Mtd	1	3.6	28.0	Scroll	1	3/4 (0.56)	2.8	PSC	6.4	7.3	15
	CWU/CGU-007S-1*	208/1/60	Indoor Ceiling Mtd	1	12.8	58.3	Scroll	---	---	---	---	12.8	16.0	25
	CWU/CGU-007S-7*	277/1/60	Indoor Ceiling Mtd	1	10.9	60.0	Scroll	---	---	---	---	10.9	13.6	20
	CWU/CGU-007S-3*	208/3/60	Indoor Ceiling Mtd	1	7.7	55.4	Scroll	---	---	---	---	7.7	9.6	15
	CWU/CGU-007S-4*	460/3/60	Indoor Ceiling Mtd	1	3.6	28.0	Scroll	---	---	---	---	3.6	4.5	15
9kW (2.5 Tons)	XPU-009S-1*	208/1/60	Outdoor Pad/Roof Mtd	1	12.8	64.0	Scroll	1	1/4 (0.19)	2.0	PSC	14.8	18.0	30
	XPU-009S-7*	277/1/60	Outdoor Pad/Roof Mtd	1	9.6	48.1	Scroll	1	1/4 (0.19)	1.5	PSC	11.1	13.5	20
	XPU-009S-3*	208/3/60	Outdoor Pad/Roof Mtd	1	8.3	58.0	Scroll	1	1/4 (0.19)	2.0	PSC	10.3	12.4	20
	XPU-009S-4*	460/3/60	Outdoor Pad/Roof Mtd	1	5.1	28.0	Scroll	1	1/4 (0.19)	1.0	PSC	6.1	7.4	15
	CCU-009S-1*	208/1/60	Indoor Ceiling Mtd	1	12.8	64.0	Scroll	1	3/4 (0.56)	5.4	PSC	18.2	21.4	30
	CCU-009S-7*	277/1/60	Indoor Ceiling Mtd	1	10.9	60.0	Scroll	1	3/4 (0.56)	3.9	PSC	14.8	17.5	25
	CCU-009S-3*	208/3/60	Indoor Ceiling Mtd	1	8.3	58.0	Scroll	1	3/4 (0.56)	5.4	PSC	13.7	15.8	20
	CCU-009S-4*	460/3/60	Indoor Ceiling Mtd	1	5.1	28.0	Scroll	1	3/4 (0.56)	2.8	PSC	7.9	9.2	15
	CWU/CGU-009S-1*	208/1/60	Indoor Ceiling Mtd	1	12.8	64.0	Scroll	---	---	---	---	12.8	16.0	25
	CWU/CGU-009S-7*	277/1/60	Indoor Ceiling Mtd	1	10.9	60.0	Scroll	---	---	---	---	10.9	13.6	20
	CWU/CGU-009S-3*	208/3/60	Indoor Ceiling Mtd	1	8.3	58.0	Scroll	---	---	---	---	8.3	10.4	15
	CWU/CGU-009S-4*	460/3/60	Indoor Ceiling Mtd	1	5.1	28.0	Scroll	---	---	---	---	5.1	6.4	15
11kW (3.0 Tons)	XPU-011S-1*	208/1/60	Outdoor Pad/Roof Mtd	1	16.7	79.0	Scroll	1	1/4 (0.19)	2.0	PSC	18.7	22.9	35
	XPU-011S-7*	277/1/60	Outdoor Pad/Roof Mtd	1	12.5	59.3	Scroll	1	1/4 (0.19)	1.5	PSC	14.0	17.2	25
	XPU-011S-3*	208/3/60	Outdoor Pad/Roof Mtd	1	10.4	73.0	Scroll	1	1/4 (0.19)	2.0	PSC	12.4	15.0	25
	XPU-011S-4*	460/3/60	Outdoor Pad/Roof Mtd	1	5.8	38.0	Scroll	1	1/4 (0.19)	1.0	PSC	6.8	8.3	15
	CCU-011S-1*	208/1/60	Indoor Ceiling Mtd	1	16.7	79.0	Scroll	1	3/4 (0.56)	5.4	PSC	22.1	26.3	40
	CCU-011S-7*	277/1/60	Indoor Ceiling Mtd	1	13.5	72.0	Scroll	1	3/4 (0.56)	3.9	PSC	17.4	20.8	30
	CCU-011S-3*	208/3/60	Indoor Ceiling Mtd	1	10.4	73.0	Scroll	1	3/4 (0.56)	5.4	PSC	15.8	18.4	25
	CCU-011S-4*	460/3/60	Indoor Ceiling Mtd	1	5.8	38.0	Scroll	1	3/4 (0.56)	2.8	PSC	8.6	10.1	15
	CWU/CGU-011S-1*	208/1/60	Indoor Ceiling Mtd	1	16.7	79.0	Scroll	---	---	---	---	16.7	20.9	35
	CWU/CGU-011S-7*	277/1/60	Indoor Ceiling Mtd	1	13.5	72.0	Scroll	---	---	---	---	13.5	16.9	30
	CWU/CGU-011S-3*	208/3/60	Indoor Ceiling Mtd	1	10.4	73.0	Scroll	---	---	---	---	10.4	13.0	20
	CWU/CGU-011S-4*	460/3/60	Indoor Ceiling Mtd	1	5.8	38.0	Scroll	---	---	---	---	5.8	7.3	15

Notes:

- 1) FLA = Full Load Amps; MCA = Min Circuit Amps; MOP = Max Overcurrent Protection (Max Fuse Size)
- 2) 277/1/60 systems may require factory provided field installed step-down transformer.
- 3) - - - - Consult local AboveAir Sales Representative for non-cataloged system power supply information.

DX - AIR & WATER / GLYCOL COOLED, REMOTE CONDENSING UNITS ... Continued from Page 19

Unit Size (Nominal)	Condenser / Cond Unit Model	Main Power Supply	Type	Compressor (Fixed Speed)				Cond Fan Motor				Unit Nameplate Data			
				Qty.	RLA	LRA	Type	Qty.	HP (kW)	FLA	Type	FLA	MCA	MOP	
12kW (3.5 Tons)	XPU-012S-1*	208/1/60	Outdoor Pad/Roof Mtd	1	16.7	109.0	Scroll	1	1/4 (0.19)	2.0	AC	18.7	22.9	35	
	XPU-012S-7*	277/1/60	Outdoor Pad/Roof Mtd	1	12.5	81.8	Scroll	1	1/4 (0.19)	1.5	AC	14.0	17.2	25	
	XPU-012S-3*	208/3/60	Outdoor Pad/Roof Mtd	1	13.5	88.0	Scroll	1	1/4 (0.19)	2.0	AC	15.5	18.9	30	
	XPU-012S-4*	460/3/60	Outdoor Pad/Roof Mtd	1	6.0	44.0	Scroll	1	1/4 (0.19)	1.0	AC	7.0	8.5	15	
	XCU-012S-1*	208/1/60	Indoor Ceiling Mtd	1	21.8	117.0	Scroll	1	1-1/2 (1.12)	7.5	AC	29.3	34.8	50	
	XCU-012S-7*	277/1/60	Indoor Ceiling Mtd	1	16.3	98.0	Scroll	1	1-1/2 (1.12)	5.6	AC	21.9	26.0	40	
	XCU-012S-3*	208/3/60	Indoor Ceiling Mtd	1	13.7	83.1	Scroll	1	1-1/2 (1.12)	5.4	AC	19.1	22.5	35	
	XCU-012S-4*	460/3/60	Indoor Ceiling Mtd	1	6.2	41.0	Scroll	1	1-1/2 (1.12)	2.8	AC	9.0	10.6	15	
	CWU/CGU-012S-1*	208/1/60	Indoor Ceiling Mtd	1	21.8	117.0	Scroll	---	---	---	---	---	21.8	27.3	45
	CWU/CGU-012S-7*	277/1/60	Indoor Ceiling Mtd	1	16.3	98.0	Scroll	---	---	---	---	---	16.3	20.4	35
	CWU/CGU-012S-3*	208/3/60	Indoor Ceiling Mtd	1	13.7	83.1	Scroll	---	---	---	---	---	13.7	17.1	30
	CWU/CGU-012S-4*	460/3/60	Indoor Ceiling Mtd	1	6.2	41.0	Scroll	---	---	---	---	---	6.2	7.8	15
14kW (4.0 Tons)	XPU-014S-1*	208/1/60	Outdoor Pad/Roof Mtd	1	19.9	109.0	Scroll	1	1/4 (0.19)	2.0	AC	21.9	26.9	45	
	XPU-014S-7*	277/1/60	Outdoor Pad/Roof Mtd	1	14.9	81.8	Scroll	1	1/4 (0.19)	1.5	AC	16.4	20.2	35	
	XPU-014S-3*	208/3/60	Outdoor Pad/Roof Mtd	1	13.1	83.1	Scroll	1	1/4 (0.19)	2.0	AC	15.1	18.4	30	
	XPU-014S-4*	460/3/60	Outdoor Pad/Roof Mtd	1	6.1	41.0	Scroll	1	1/4 (0.19)	1.0	AC	7.1	8.6	15	
	XCU-014S-1*	208/1/60	Indoor Ceiling Mtd	1	21.4	135.0	Scroll	1	1-1/2 (1.12)	7.5	AC	28.9	34.3	50	
	XCU-014S-7*	277/1/60	Indoor Ceiling Mtd	1	18.8	118.0	Scroll	1	1-1/2 (1.12)	5.6	AC	24.4	29.1	45	
	XCU-014S-3*	208/3/60	Indoor Ceiling Mtd	1	14.5	98.0	Scroll	1	1-1/2 (1.12)	5.4	AC	19.9	23.5	35	
	XCU-014S-4*	460/3/60	Indoor Ceiling Mtd	1	6.3	55.0	Scroll	1	1-1/2 (1.12)	2.8	AC	9.1	10.7	15	
	CWU/CGU-014S-1*	208/1/60	Indoor Ceiling Mtd	1	21.4	135.0	Scroll	---	---	---	---	---	21.4	26.8	45
	CWU/CGU-014S-7*	277/1/60	Indoor Ceiling Mtd	1	18.8	118.0	Scroll	---	---	---	---	---	18.8	23.5	40
	CWU/CGU-014S-3*	208/3/60	Indoor Ceiling Mtd	1	14.5	98.0	Scroll	---	---	---	---	---	14.5	18.1	30
	CWU/CGU-014S-4*	460/3/60	Indoor Ceiling Mtd	1	6.3	55.0	Scroll	---	---	---	---	---	6.3	7.9	15
18kW (5.0 Tons)	XPU-018S-1*	208/1/60	Outdoor Pad/Roof Mtd	1	26.4	134.0	Scroll	1	1/4 (0.19)	2.0	AC	28.4	35.0	60	
	XPU-018S-7*	277/1/60	Outdoor Pad/Roof Mtd	1	19.8	100.6	Scroll	1	1/4 (0.19)	1.5	AC	21.3	26.3	45	
	XPU-018S-3*	208/3/60	Outdoor Pad/Roof Mtd	1	16.0	110.0	Scroll	1	1/4 (0.19)	2.0	AC	18.0	22.0	35	
	XPU-018S-4*	460/3/60	Outdoor Pad/Roof Mtd	1	7.8	52.0	Scroll	1	1/4 (0.19)	1.0	AC	8.8	10.8	15	
	XCU-018S-1*	208/1/60	---	---	---	---	---	---	---	---	---	---	---	---	
	XCU-018S-7*	277/1/60	---	---	---	---	---	---	---	---	---	---	---	---	
	XCU-018S-3*	208/3/60	Indoor Ceiling Mtd	1	15.6	110.0	Scroll	1	2 (1.49)	6.9	AC	22.5	26.4	40	
	XCU-018S-4*	460/3/60	Indoor Ceiling Mtd	1	7.8	52.0	Scroll	1	2 (1.49)	3.5	AC	11.3	13.3	20	
	CWU/CGU-018S-1*	208/1/60	Indoor Ceiling Mtd	1	26.3	134.0	Scroll	---	---	---	---	---	26.3	32.9	50
	CWU/CGU-018S-7*	277/1/60	Indoor Ceiling Mtd	1	19.9	128.0	Scroll	---	---	---	---	---	19.9	24.9	40
	CWU/CGU-018S-3*	208/3/60	Indoor Ceiling Mtd	1	15.6	110.0	Scroll	---	---	---	---	---	15.6	19.6	35
	CWU/CGU-018S-4*	460/3/60	Indoor Ceiling Mtd	1	7.8	52.0	Scroll	---	---	---	---	---	7.8	9.7	15

Notes:

- 1) FLA = Full Load Amps; MCA = Min Circuit Amps; MOP = Max Overcurrent Protection (Max Fuse Size)
- 2) 277/1/60 systems may require factory provided field installed step-down transformer.
- 3) ---- Consult local AboveAir Sales Representative for non-cataloged system power supply information.

DX - Air Cooled

WCH & XPU-()

DX - Air Cooled Split with Propeller Fan,
Outdoor Remote Condensing Unit



WCH with CCU or XCU -()

DX - Air Cooled Split with Centrifugal Blower,
Indoor Remote Condensing Unit

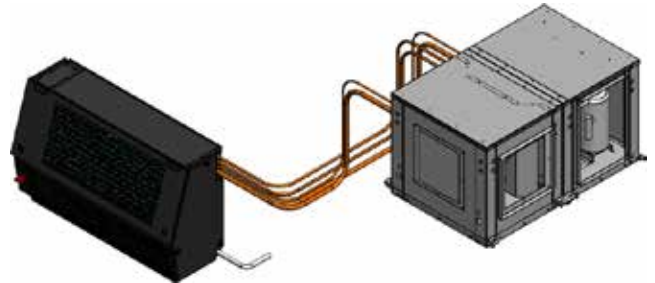

DX - Water / Glycol Cooled

WCH with CWU or CGU -()

DX - Water/Glycol Cooled Split with Indoor Condensing Unit

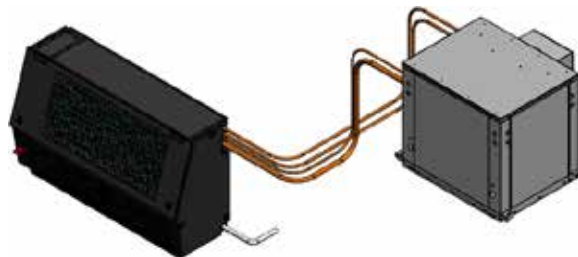

Chilled Water Systems

WCC-()

Chilled Water Air Handling Units



4-18kW (1-5 Tons) ... w/o Humidifier Option

(WCH or WCC-004 thru 018-_-__0)

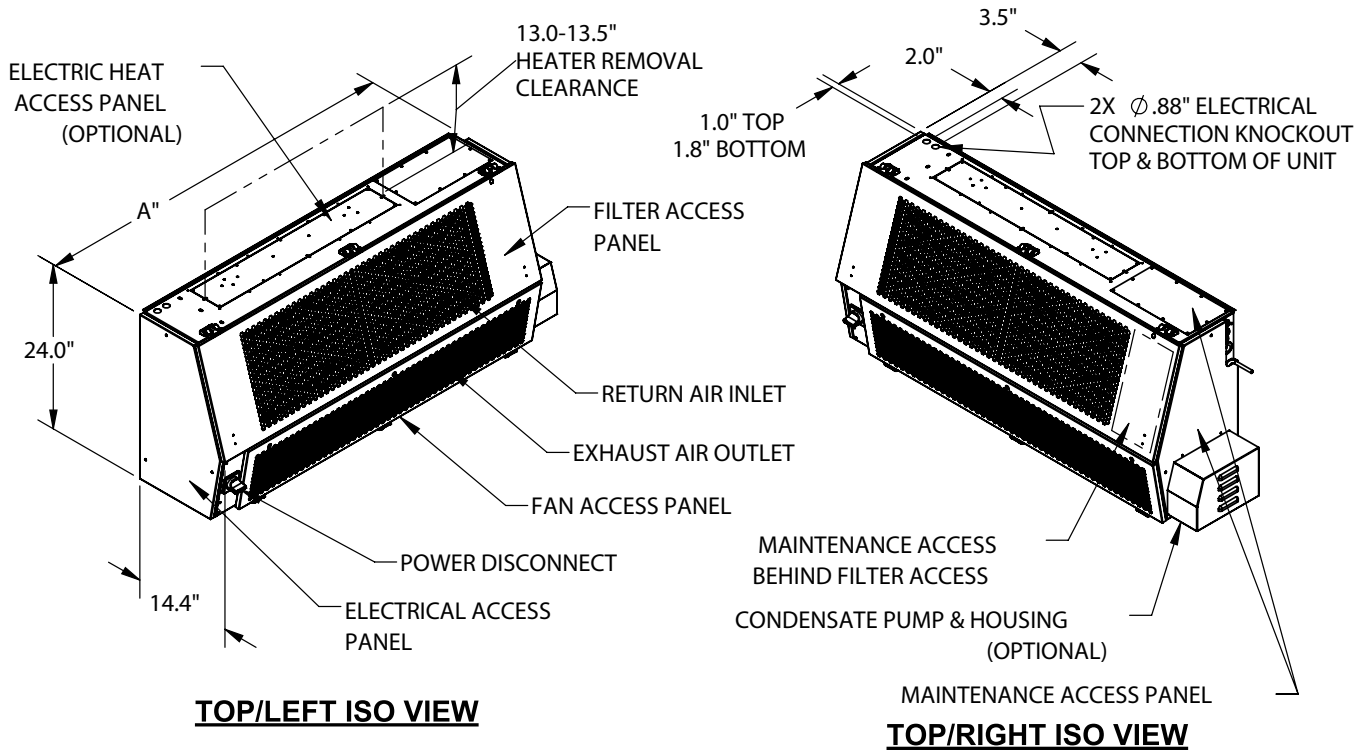

TOP/LEFT ISO VIEW

TOP/RIGHT ISO VIEW

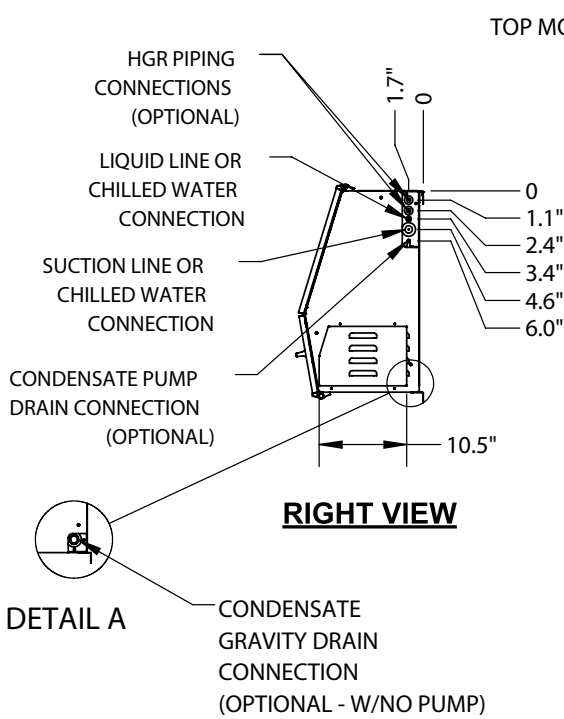

RIGHT VIEW

DETAIL A
CONDENSATE GRAVITY DRAIN CONNECTION (OPTIONAL - W/NO PUMP)

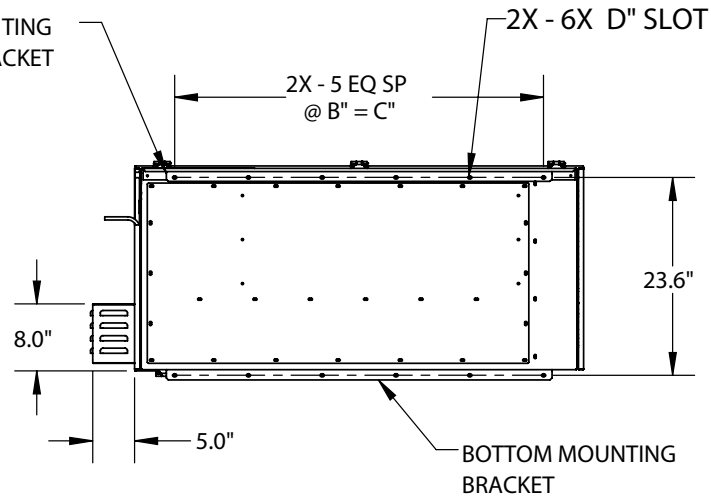

REAR VIEW WITH MOUNTING DIMENSIONS

TABULATED DIMENSIONS				
Unit Capacity	A	B	C	D
4-7kW (1-2T)	43.5	6.8	34.0	0.28 X 0.50
9-11kW (2.5-3T)	53.5	8.8	44.0	0.28 X 0.50
12-18kW (3.5-5T)	71.5	12.4	62.0	0.38 X 0.63

(MD601X-V2-1A)

4-18kW (1-5 Tons) ... w/ Humidifier Option

(WCH or WCC-004 thru 018-_-__H)

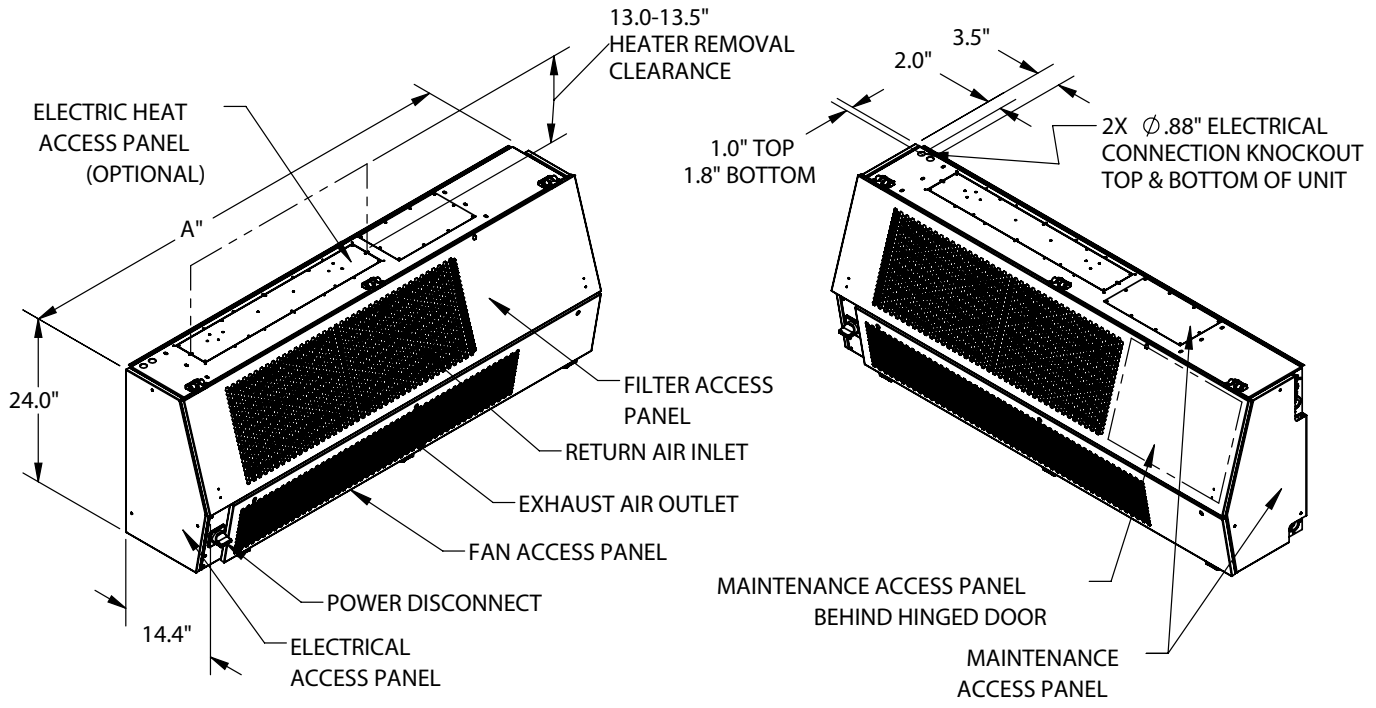

TOP/LEFT ISO VIEW

TOP/RIGHT ISO VIEW

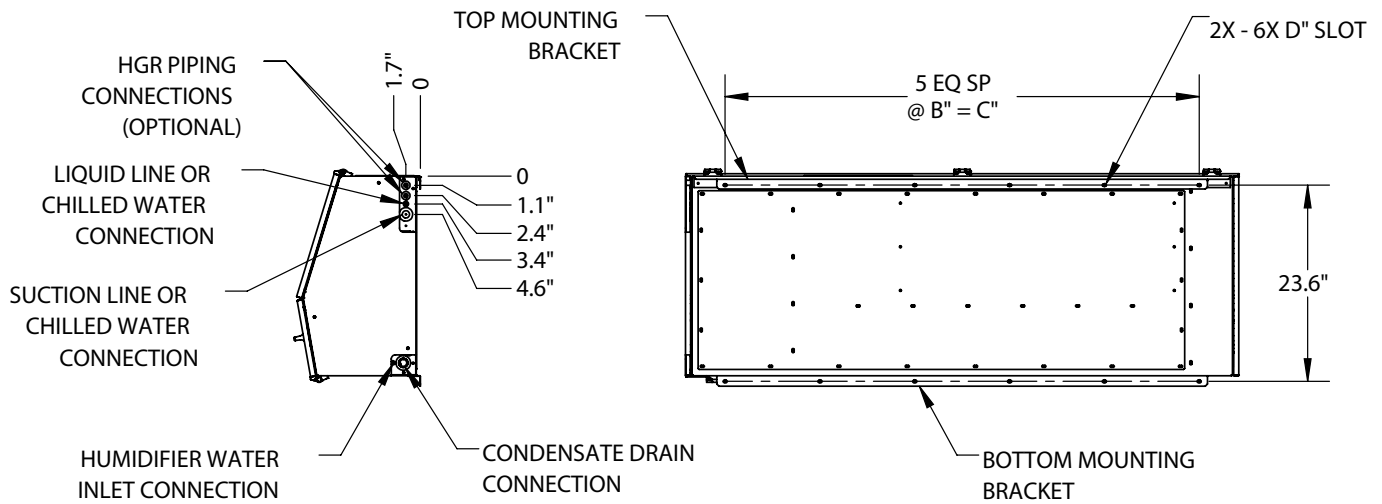

RIGHT VIEW

REAR VIEW WITH MOUNTING DIMENSIONS

TABULATED DIMENSIONS				
Unit Capacity	A	B	C	D
4-7kW (1-2T)	56.5	9.4	47.0	0.28 X 0.50
9-11kW (2.5-3T)	66.5	11.4	57.0	0.28 X 0.50
12-18kW (3.5-5T)	84.5	15.0	75.0	0.38 X 0.63

(MD601X-V2-2)

Dimensional Data - Remote Air Cooled Condensers

4-18kW (1-5 Tons), Outdoor, DX - Air Cooled Propeller Fan, Remote Condensing Units & Condensers Models: XPU & XP1-005 thru 018

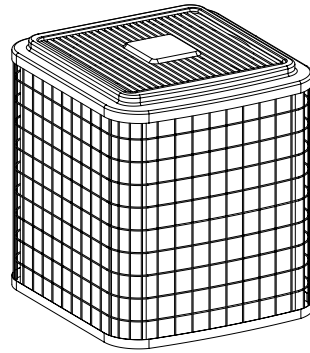

FRONT / LEFT / TOP

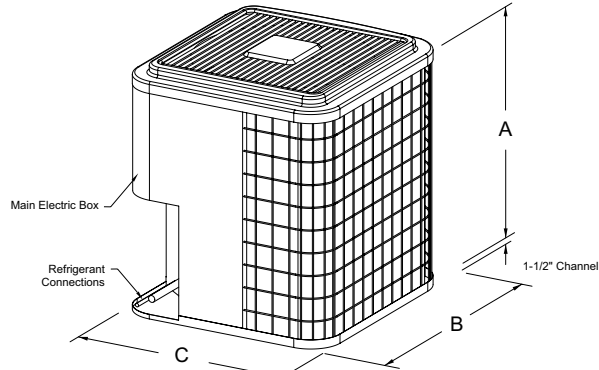

REAR / LEFT / TOP

XPU(-) Model No.	Unit Size (Nominal)	DIMENSIONS (inches)		
		A	B	C
XPU-004	4kW (1T)	24-13/16	23-1/8	23-1/8
XPU-005	5kW (1.5T)	25	25-3/4	25-3/4
XPU-007	7kW (2T)	28-11/16	23-1/8	23-1/8
XPU-009	9kW (2.5T)	31-3/16	25-3/4	25-3/4

XPU(-) Model No.	Unit Size (Nominal)	DIMENSIONS (inches)		
		A	B	C
XPU-011	11kW (3T)	32-5/16	31-3/16	31-3/16
XPU-012	12kW (3.5T)	35-3/4	31-3/16	31-3/16
XPU-014	14kW (4T)	35-3/4	31-3/16	31-3/16
XPU-018	18kW (5T)	28-15/16	31-3/16	31-3/16

4-11kW (1-3 Tons), Indoor Ceiling Mounted, Remote Centrifugal Blower DX - Air Cooled Condensing Units & Condensers “Same-Face (standard) or Optional Straight-Thru & “90° L” Air Patterns” Models: CCU & CCX-005 thru 011

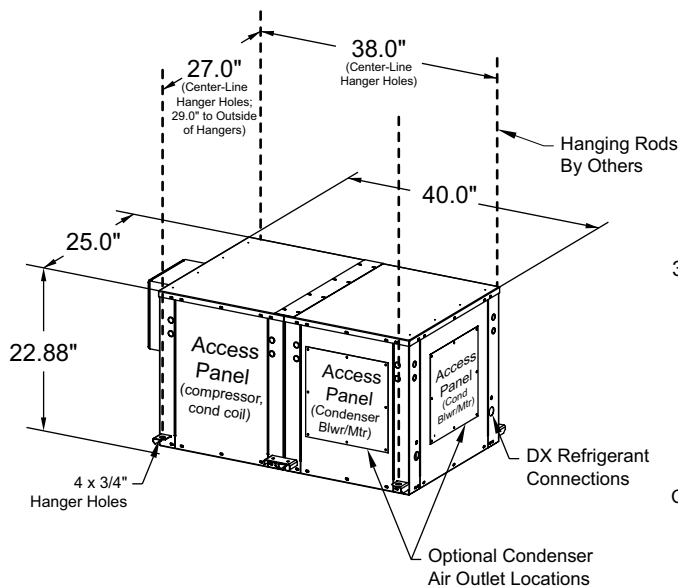

Front / Right / Top

3-Side Access:
18"-24" on Front, Left & Right Sides!

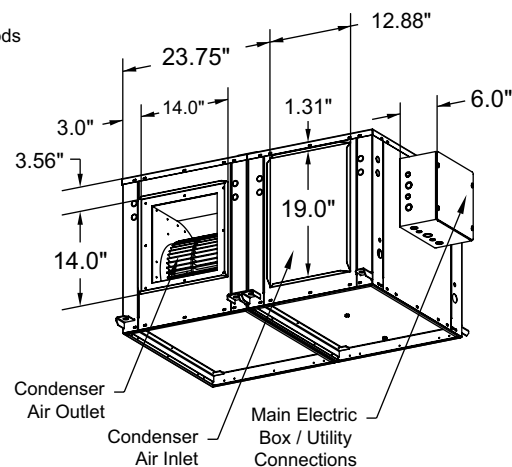

Rear / Left / Bottom

Belt-Driven: 4-18kW (1-5 Tons), Indoor Ceiling Mtd, Centrifugal Blower DX Air Cooled, Remote Condensing Units **“Same-Face (standard) or Optional Straight-Thru & “90° L” Air Patterns”**

2-Side Access:
 18"-24" on Left & Right Sides!

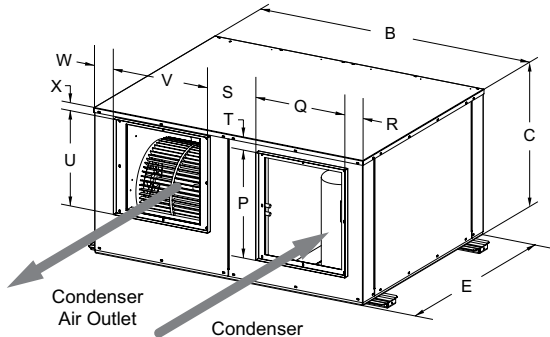

FRONT / RIGHT / TOP

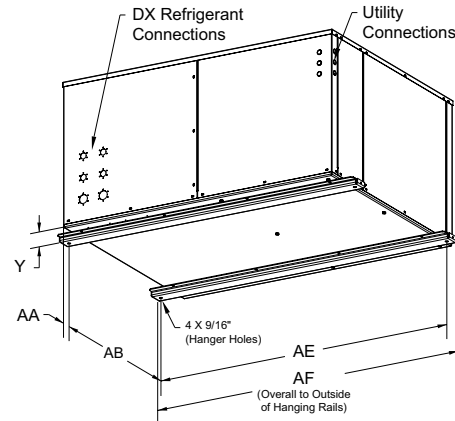

REAR / LEFT / BOTTOM

DIMENSIONS (inches)																	
XCU(-) Model No.	B	C	E	P	Q	R	S	T	U	V	W	X	Y	AA	AB	AE	AF
004, 005, 007, 009 & 011	44	22	34	16	16	2-3/4	6-7/8	2	16	16	2-3/8	1-5/16	1	5	24	47-1/2	50
014 & 018	54	27	42	20	18	3	9-5/8	2	17-3/8	19	4-3/8	1	1	5	32	57-1/2	60

4-18kW (1-5 Tons), Indoor, DX Water/Glycol Cooled, Remote Condensing Units Models: CWU & CGU-005 thru 018

3-Side Access:
 18"-24" on Front, Left & Right Sides!

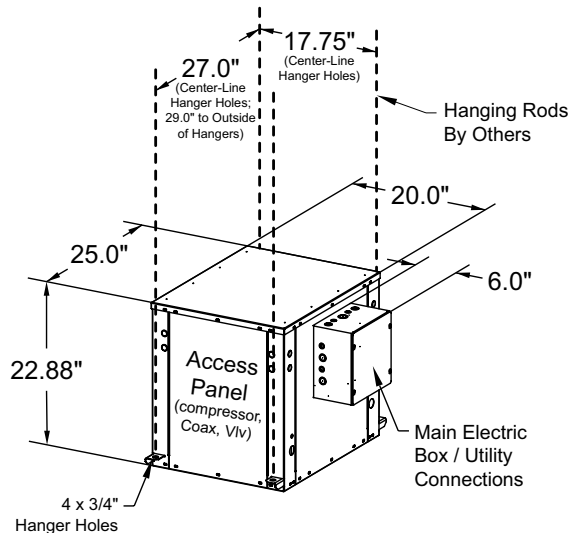

Front / Right / Top

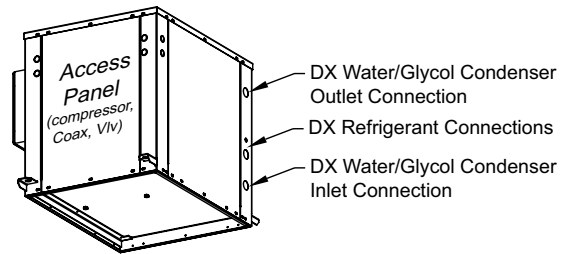

Rear / Left / Bottom

Innovative HVAC Solutions

MissionCritical Units - Precision A/C's



**SC-2x4 SpotCool
Ceiling Mounted A/C's**
(4-11kW, 1-3 Tons)



**HK Horizontal Ducted
Ceiling Mounted A/C's**
(4-70kW, 1-20 Tons)



**MC Vertical Floor Mtd A/C's
Up-Flow & Down-Flow**
(4-1080kW, 1-307 Tons)



**WC Wall-Cassette and
FC Floor-Console Mtd A/C's**
(4-18kW, 1-5 Tons)

Outdoor-Air Units - IAQ High Percent (20%-100% OA)



HK-OA Horizontal Ceiling Mtd
(1-30 Tons)



VK-OA Vertical Floor Mtd
(1-50 Tons)

Specialty Units - A/C's & Water Source Heat Pumps



**SC-2x4 SpotCool
Ceiling Mtd A/C's**
(4-11kW, 1-3 Tons)



**HK Horizontal Packaged
& Split Ceiling Mtd A/C's**
(4-70kW, 1-20 Tons)



**VK Vertical Packaged &
Split Floor Mtd A/C's**
(4-105kW, 1-30 Tons)

Remote Heat Rejection Units



**Remote Air Cooled
Condensers, Condensing Units &
Glycol Drycoolers**

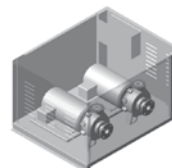

**Single, Dual & Triplex
Glycol Pump Packages**
(1/2 to 50 HP, VFD Optional)