

Engineering Manual

SC™ SpotCool

Mission Critical

Ceiling Mounted A/C's
(Single Circuit DX & CW)

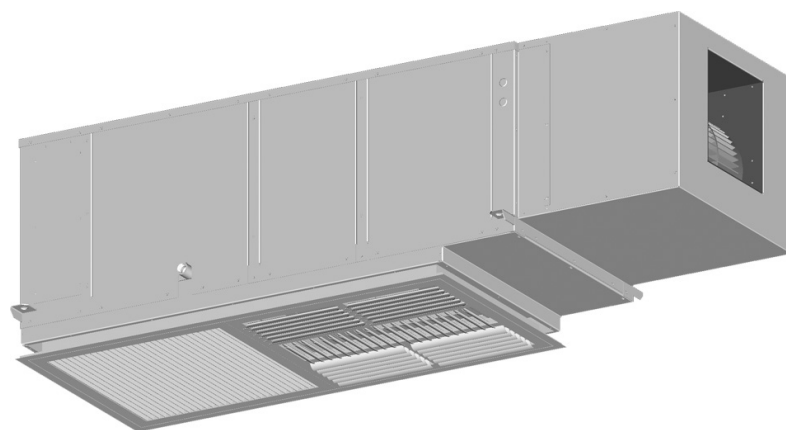

Features & Benefits

- > 4 to 11 kW (1-3 Tons) Capacities
- > Precision Applications
 - Small Computer Rooms
 - Network Closets
 - IDF / MDF / AV Rooms
 - Equipment Control Rooms
- > Floor Space-Saving Wall Mounted
- > 2' by 4' Ductless Spot Cooler or Optional Ducted Evaporator
- > DX Air, Water & Glycol Cooled Plus Chilled Water Systems
- > Total Temp & Humidity Control
 - Free-Energy Hot Gas Reheat or Electric Reheat/Heat
 - Steam Humidifier
- > Microprocessor Controls & More

From
4 to 11 kW

Small Data Rooms

AboveAir™ ceiling mounted air conditioners & heat pumps are the space saving environmental control solution to your comfort and precision cooling needs. Available in a wide variety of cooling methods and cabinet configurations including a full range of options, **AboveAir™** ceiling mounted Air Conditioners are a step above!

- ☑ Hidden above-the-ceiling installation
- ☑ Space saving ductless “spot-cooler” air pattern
- ☑ Environmentally friendly R410a refrigerant
- ☑ Variety of cooling methods
- ☑ Self-contained & split systems
- ☑ Flexible options and accessories
- ☑ Energy efficient operation
- ☑ Low sound operation

Contents

Introduction	2
Features and Benefits	3
Model Nomenclature	4
Guide Specifications	5-10
Performance Data	11-14
Electrical Data	15-18
Approximate Unit Weights (lbs)	19
Dimensional Data	20-30

DX - Air Cooled

SCA-()
DX - Air Cooled Self-Contained

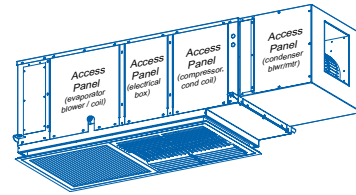

SCH/SCE & CCU/CCX -()
DX - Air Cooled Split with Centrifugal Blower
Indoor / Outdoor Remote Condensing Unit & Condensers

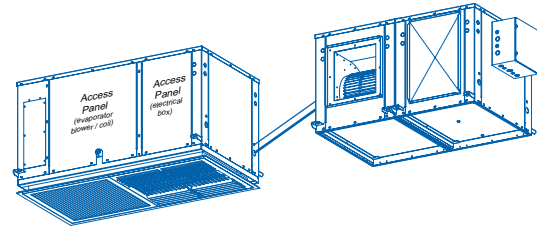

SCH/SCE & XPU/XP1-()
DX - Air Cooled Split with Propeller Fan
Outdoor Remote Condensing Unit & Condensers

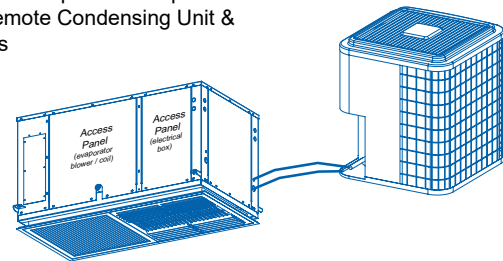

DX - Water/Glycol Cooled

SCW & SCG-()
DX - Water/Glycol Cooled Self-Contained

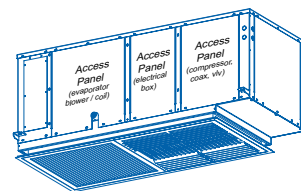

*** Split Water/Glycol also Available!**
(SPH & CWU/CGU)

Chilled Water Systems

SCC-()
Chilled Water Air Handling Units

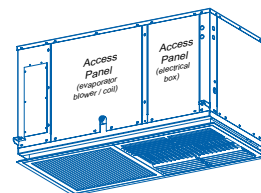

AboveAir™ Spot Coolers are designed to meet your unique application dependent requirements. Select from a wide range of options and configurations:

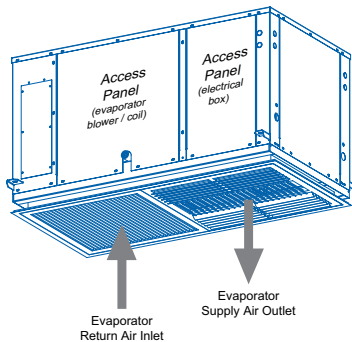

Spot Cooler with Integral Return-Filter & 3-Way Supply Grille

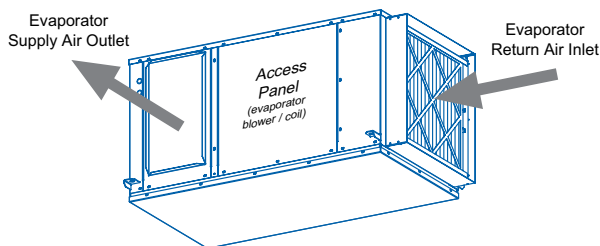

Optional Ducted Supply & Return Connections



Select Options:

- Digital Heat/Cool Thermostats
- Temp & Humid Microprocessor Controls with Alarms and Optional BMS Communications
- Steam Canister Humidifier
- Heating Mode with Electric Heating Coil
- Dehumidification Mode with Electric or Hot Gas Reheat
- Scroll Compressor (Fixed, 2-Spd or Digital)
- High Efficiency Air Filtration
- Low Ambient Head Pressure Control
- 2 & 3-way 150 psig to 400 psig Water/ Glycol Cooled Regulating Valves
- Hot Gas Bypass
- Low Entering Condenser Water/Glycol Kit
- EC (electronically commutated) Motors

Select Accessories:

- Condensate Pumps
- Main Power Electrical Disconnects
- Firestats
- Smoke Detectors
- Remote Water Detectors
- Compressor Sound Jackets
- Hanging Vibration Isolators
- Glycol Pump Packages & Drycoolers
- ... and more!



Model Nomenclature

Packaged Systems & Split Evaporators

Split, DX - Remote Condensers & Condensing Units

SC	E - 036	S - 4 - HG	00	H - ED - TB	C - 3	0
a	b - c	d - e - f	g	h - i - j	k - l	m

- a: SC** - SpotCool 2x4 Ceiling Mounted A/C
- b: A** - DX, Air Cooled - Packaged Self-Contained
C - Chilled Water Air Handling Unit
E - DX, Split Evaporator (Compressor with Evaporator)
G - DX, Glycol Cooled - Packaged Self-Contained
H - DX, Split Air Handling Unit
W - DX, Water Cooled - Packaged Self-Contained
- c: 012** = 1.0-Ton (4.0kW); **018** = 1.5-Tons (5kW); **024** = 2.0-Tons (7kW);
030 = 2.5-Tons (9kW); **036** = 3.0-Tons (11kW)
- d: S** - Single Circuit DX System
X - Chilled Water System
- e: 1** - 208-230V / 1 Ph / 60 Hz
3 - 208-230V / 3 Ph / 60 Hz
4 - 460-480V / 3 Ph / 60 Hz
5 - 575V / 3 Ph / 60 Hz
7 - 277V / 1 Ph / 60 Hz
8 - 460-480V / 1 Ph / 60 Hz
- f: 00** - No Hot Gas Reheat
HG - Hot Gas Reheat (2-POS, On/Off)
- g: 00** - No Unit Mtd Electric Heat
EO - Electric Heat Only, No Reheat
ER - Electric Reheat/Heat
- h: 0** - No Humidifier
H - Electrode Canister Steam Humidifier
- i: AD** - Direct-Drive DWDI FC Blower w/ PSC Motor
ED - Direct-Drive DWDI FC Blower w/ ECM Motor
- j: FD** - Ducted Front Discharge Evaporator Air Pattern - Optional
(Consult Factory for unit dimensional details!)
RD - Ducted Rear Discharge Evaporator Air Pattern
ST - Ducted Straight-Thru Evaporator Air Pattern - Optional
(Consult Factory for unit dimensional details!)
TB - Tee-Bar Layin w/ Bottom 2x4 Supply & Return Filter Grille
- k: C** - A = 1-2T (4-7kW) Cabinet; B = 2.5T (9kW) Cabinet; C = 3T (11kW) Cabinet; D = Low-Profile (16"H SC-A Cabinet);
E = Low-Profile (21"H SC-B Cabinet); E = Low-Profile (21"H SC-C Cabinet)
- l: 0** - No Compressor (*Compressor located in remote condensing section*)
1 - Fixed Speed Scroll Compressor w/ Hot Gas Bypass
3 - 2-Speed Scroll Compressor Option
A - Chilled Water Valve - 2-Way, 300 psi (ON/OFF, 2-POS)
B - Chilled Water Valve - 3-Way, 300 psi (ON/OFF, 2-POS)
C - Chilled Water Valve - 2-Way, 300 psi (MOD, 0-10 VDC)
D - Chilled Water Valve - 3-Way, 300 psi (MOD, 0-10 VDC)
E - Chilled Water Valve by Others
- m: 0** - Not Applicable / No Head Pressure Control
1 - Low Amb ECM Variable Speed Fan Head Pressure Control
A - Low Amb Fan Cycling Head Pressure Control
B - Low Amb Variable Speed Fan Head Pressure Control
C - Low Amb Flooded Head Pressure Control
D - Water/Glycol Regulating Valve - 2-Way, 150 psig
E - Water/Glycol Regulating Valve - 2-Way, 350 psig
F - Water/Glycol Regulating Valve - 3-Way, 150 psig
G - Water/Glycol Regulating Valve - 3-Way, 350 psig

XP1 - 036	S - 4 - AA - VF	1 - 0	A
a - b	c - d - e - f	g - h	i

- a: CCU** - DX, Split Indoor Ceiling Mtd Remote Air Cooled Centrifugal Blower Condensing Unit (Compr w/ CCU Cond Unit)
CCX - DX, Split Indoor Ceiling Mtd Remote Air Cooled Centrifugal Blower Condenser (Compr Located w/ SCE Evap)
CGU - DX, Split Indoor Ceiling or Floor Mtd Remote Glycol Cooled Condensing Unit (Compr w/ CGU Cond Unit)
CWU - DX, Split Indoor Ceiling or Floor Mtd Remote Water Cooled Condensing Unit (Compr w/ CWU Cond Unit)
XP1 - DX, Split Outdoor Mtd Remote Air Cooled Propeller Fan Condenser (Compr Located w/ SCE Evap)
XPU - DX, Split Outdoor Mtd Remote Air Cooled Propeller Fan Condensing Unit (Compr w/ XPU Cond Unit)
- b: 012** = 1.0-Ton (4.0kW); **018** = 1.5-Tons (5kW); **024** = 2.0-Tons (7kW);
030 = 2.5-Tons (9kW); **036** = 3.0-Tons (11kW)
- c: S** - Single Circuit DX System
- d: 1** - 208-230V / 1 Ph / 60 Hz
3 - 208-230V / 3 Ph / 60 Hz
4 - 460-480V / 3 Ph / 60 Hz
5 - 575V / 3 Ph / 60 Hz
7 - 277V / 1 Ph / 60 Hz
8 - 460-480V / 1 Ph / 60 Hz
- e: 00** - N/A
AA - Axial Fan w/ Std Motor
AB - DWDI FC BD Blower w/ ODP Motor
AD - Direct-Drive DWDI FC Blower w/ PSC Motor
EA - Axial Fan w/ ECM
EC - EC DD Backward-Inclined Impeller
ED - Direct-Drive DWDI FC Blower w/ ECM Motor
- f: 00** - Not Applicable
LD - Ducted, 90 Degree / Right-Angle, In-Front / Out Left-Side
MI - Ducted, Mirror-Image Same-Face Condenser Air Pattern
RD - Ducted, 90 Degree / Right-Angle, In-Rear / Out Right-Side
SF - Ducted, Same Face Condenser Air Pattern
ST - Ducted, Straight-Thru Condenser Air Pattern
VF - Free Airflow, Vertical Discharge Air Pattern
- g: 0** - Not Applicable
1 - Slab or Wrap Around Type Condenser/Condensing Unit
S - SpotCool Condenser Section
- h: 0** - No Compressor (*Compressor located in evaporator section*)
1 - Fixed Speed Scroll Compressor w/ Hot Gas Bypass
2 - Fixed Speed Scroll Compressor w/ Quench Hot Gas Bypass
3 - 2-Speed Scroll Compressor Option
- i: 0** - Not Applicable / No Head Pressure Control
1 - Low Amb ECM Variable Speed Fan Head Pressure Control
A - Low Amb Fan Cycling Head Pressure Control
B - Low Amb Variable Speed Fan Head Pressure Control
C - Low Amb Flooded Head Pressure Control
D - Water/Glycol Regulating Valve - 2-Way, 150 psig
E - Water/Glycol Regulating Valve - 2-Way, 350 psig
F - Water/Glycol Regulating Valve - 3-Way, 150 psig
G - Water/Glycol Regulating Valve - 3-Way, 350 psig

General

Summary

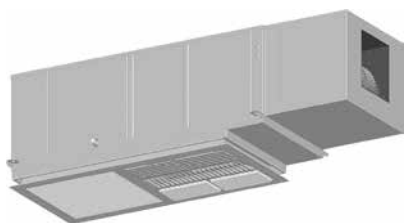

These specifications describe the requirements for a horizontal ceiling mounted air conditioner. The system shall be designed to control space temperature and humidity.

The air conditioning manufacturer shall design and furnish all equipment in the quantities and configurations shown on the project plans and specifications.

The system shall be provided by Above-Air Technologies in Frederick, Maryland, USA. The system shall be listed by Intertek (ETL Semko), Inc. to conform with UL Std 1995 and be certified to CAN/CSA Std C22.2 No. 236 (Control No. 3091370). The system shall be NYC MEA230-06-E and Chicago Code approved. The system model number shall be _____.

Design Requirements

The system shall be an AboveAir SC™ 2x4 SpotCool brand factory assembled and tested. Evaporator sections shall be designed for above the drop-ceiling installation. Remote condensers and condensing unit sections shall be designed for either outdoor slab or indoor above the drop-ceiling installation.

The system shall have a total cooling capacity of _____ BTU/H, and a sensible cooling capacity of _____ BTU/H, based on an entering air condition of _____ °F DB, and _____ °F WB, _____ % RH.

The evaporator section shall be designed for _____ Volt, _____ Phase, _____ Hertz main power supply. The remote condensing unit section (if applicable) shall be designed for _____ Volt, _____ Phase, _____ Hertz main power supply.

Submittals

Submittals shall be provided after manufacturer's receipt of a written purchase order and shall include: Detailed Performance and Electrical Data; Guide Specifications; and Dimensional Drawings.

1.4 Quality Assurance

The system shall be factory tested prior to shipment. Testing shall include, but shall not be limited to: system and component operational and functional testing; electrical "HiPot" insulation test; refrigerant and water piping circuit pressuring testing per UL 1995 Safety Standard for Heating and Cooling Equipment. The system shall be designed and manufactured according to world class quality standards.

Products

Standard Features

Cabinet

The cabinet chassis and access panels shall be constructed of heavy gauge galvanized steel. Cabinet access panels shall rest in recessed pockets designed for minimum air leakage. The cabinet and access panels shall be lined with 2 lb/ft² high density sound and thermal insulation and sealed with self-extinguishing gasketing conforming to NFPA 90A and 90B.

Component Access

The unit shall be serviceable within the ceiling through large side access panels and shall require only 2-side access.

Electrical System



General:

The electrical system shall conform to National Electric Code (NEC) requirements according to UL 1995. The control circuit shall be a 24 VAC low voltage circuit.

The electrical system shall include, but not be limited to the following factory installed items: 24 VAC control transformer; terminal connections; grounding lug; overload protection; and starter/contactors for blower motor, compressor, humidifier and each electric heater stage

Overflow Safety Float:

The system shall be provided with a factory installed float type condensate pan overflow safety switch. The circuit shall be designed to shut down all system water producing operations in the event of an overflow condition.

Packaged Systems: (single point power) Self-Contained systems shall be designed for single point main power connection.

Split DX Systems: (separate power) Split systems shall require separate main power supplies to the evaporator and remote heat rejection sections. The evaporator and remote heat rejection sections shall be electrically interlocked by a field wired 24 volt control signal.

Air Distribution

Evaporator Blower/Motor



The evaporator blower assembly shall be designed for _____ CFM @ _____ inches external static pressure (e.s.p.)

The blower shall be the direct-driven centrifugal type, double width double inlet (DWDI), and statically and dynamically balanced to a minimum vibration level.

Variety of Air Patterns

Air Pattern (Spot-Cooler)

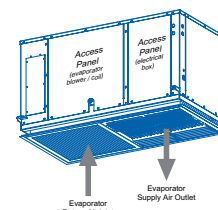

An integral 3-way supply and return-filter grille shall be factory provided for field installation. The grille assemble shall be designed for standard 2'x4' T-Bar ceiling installation.

Ducted Evap Supply & Return

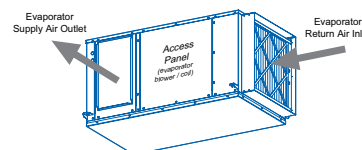

The system shall be provided with

flanged connections for field ducting of evaporator return air inlet and supply air discharge. The filter(s) shall be 1 inch thick and rated for 20% dust spot efficiency (based on ASHRAE 52.1). The filter shall be serviceable via side access and without shutting down the unit.

Air Filtration



The filter shall be 1 inch thick throwaway and Merv-8 efficiency rated (based on ASHRAE 52.2). The filter shall be serviceable through a hinged bottom access return grille (spotcoolers) or end / side access panel (ducted) without shutting down the system.

Direct Expansion Systems

DX - Evaporator Coils



The DX evaporator coil shall be constructed of copper tubes and aluminum fins. Coil end-plates shall be hot dipped galvanized. The evaporator coil shall be mounted in an insulated stainless steel condensate drain pan.

Scroll Compressors



The compressor shall be the high efficiency, low sound power scroll type. The compressor shall be mounted on vibration isolators. The compressor shall be complete with reversible positive oil pump, charging and service ports, internal spring isolation, and discharge gas vibration eliminator.

DX - Refrigeration Circuits



Each refrigeration circuit shall be pre-piped with ACR refrigerant copper tubing. The refrigeration system shall include, but not be limited to: expansion valve with external equalizer; sight glass; refrigerant filter-drier; refrigerant access valves and high & low refrigerant pressure safety switches.

Cooling Configurations

DX - Air Cooled Systems

DX - Air Cooled Self-Contained Systems, SCA-()

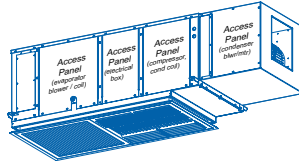

The system shall be a self-contained, ceiling mounted precision air conditioner with factory mounted integral dx air cooled condenser with direct-driven centrifugal blower. The condenser shall be sized for full heat of rejection at 95°F ambient and be capable of operation to 5°F low ambient air temperature.

The system shall ship from the factory as a one-piece unit; no field connection of condenser blower/motor shall be required. The system shall require only single point main power supply and shall ship from the factory with a full operating refrigerant charge.

DX - Air Cooled Split

Air Handling & Outdoor Remote Condensing Units, SCH-() & XPU-()

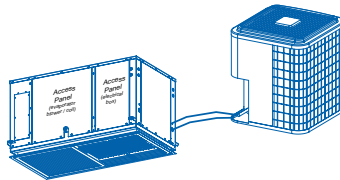

The system shall be a split configuration with indoor ceiling mounted precision dx air handling unit and remote outdoor air cooled propeller fan condensing unit. The compressor shall be located in the condensing unit. The condensing unit shall be sized for full heat of rejection at 95°F ambient and be capable of operation to 5°F low ambient air temperature.

The system shall factory tested prior to shipment. The air handling and condensing unit sections shall ship separately from the factory with a dry-nitrogen holding charge for field sweat (copper) connection and refrigerant charging.

DX - Air Cooled Split

(Split Evap & Outdoor Remote Condenser, SCE-() & XP1-())

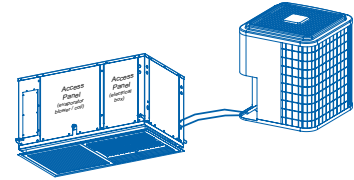

The system shall be a split configuration with indoor ceiling mounted precision dx evaporator and outdoor dx air cooled propeller fan remote condenser. The compressor shall be located in the indoor evaporator section. The condenser shall be sized for full heat of rejection at 95°F ambient and be capable of operation to 5°F low ambient air temperature.

The system shall be refrigerant charged and run tested at the factory prior to shipment. The evaporator and condenser sections shall ship separately with a dry-nitrogen charge ready for field refrigerant charging.

DX - Air Cooled Split

Air Handler & Indoor Remote Condensing Unit, SCH-() & CCU or XCU-()

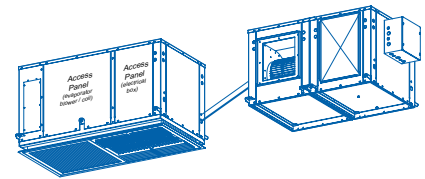

The system shall be a split configuration with indoor ceiling mounted precision dx air handling unit and remote indoor (optional outdoor) air cooled centrifugal blower condensing unit. The compressor shall be located in the condensing unit. The condensing unit shall be sized for full heat of rejection at 95°F ambient and be capable of operation to 5°F low ambient air temperature.

The system shall factory tested prior to shipment. The air handling and condensing unit sections shall ship separately from the factory with a dry-nitrogen holding charge for field sweat (copper) connection and refrigerant charging.

DX - Water Cooled Systems

DX - Water Cooled

Self-Contained Systems, SCW-()

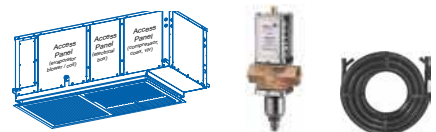

The system shall be a self-contained, ceiling mounted precision air conditioner

with integral dx water cooled condensing unit. The system shall include a water cooled tube-in-tube coaxial condenser and factory installed head pressure controlling 2-way water regulating valve rated for 150 psi w.w.p. The water cooled condenser shall be designed to provide the total required system heat of rejection at 85°F entering water temperature and 95°F leaving water temperature. Source water shall be provided by a remote water source (*by others*).

The system shall require only single point main power supply and shall ship from the factory with a full operating refrigerant charge.

DX - Glycol Cooled Systems

DX - Glycol Cooled

Self-Contained Systems, SCG-()



The system shall be a self-contained, ceiling mounted precision air conditioner with integral dx glycol cooled condensing unit. The system shall include a glycol cooled tube-in-tube coaxial condenser and factory installed head pressure controlling 2-way glycol regulating valve rated for 150 psi w.w.p. The condenser shall be designed to provide the total required system heat of rejection at 110°F entering glycol temperature and 120°F leaving glycol temperature based on 40% ethylene glycol solution. Source glycol shall be provided by a remote glycol drycooler source (*see AboveAir Technologies' FluidCool™ drycoolers*).

The system shall require only single point main power supply and shall ship from the factory with a full operating refrigerant charge.

(Note: Higher pressure and 3-way valves are optionally available, see option 2.4.3.)

Glycol Pump Packages & Drycoolers

FC_-() / PA_-()



Glycol condenser source shall be provided by a FluidCool™ brand remote air cooled glycol drycooler and Pump-All™ brand pump package.

The glycol drycooler shall be the outdoor

mounted propeller fan type complete with factory installed aquastat fan cycling controls, motor starters with overload protection and non-fused disconnect switch.

The glycol pump package shall be a (single or dual) pump package designed for outdoor installation complete with individual pump motor starters. Dual glycol pump packages shall be provided with manual lead-lag switch and field installed flow switch for automatic switchover to backup pump upon loss of flow.

An expansion tank and air purge fitting valve shall be factory provided for field installation.

The drycooler shall provide _____ BTUH total heat rejection at a flow rate of _____ GPM with _____ °F EGT and _____ °F LGT at _____ °F ambient air temperature. Each pump shall be _____ Hp and shall be sized to provide _____ GPM @ _____ Ft. w.g. total system head. The glycol solution shall be _____ % (*ethylene or propylene*) by volume.

The drycooler and pump package shall be designed for _____ Volt, _____ Phase, _____ Hertz main power supply.

(Note: See AboveAir Technologies' Fluid-Cool™ indoor & outdoor glycol drycooler and PumpAll™ glycol pump packages engineering manuals for more information.)

Chilled Water Systems

SCC-()

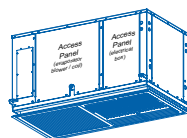

The system shall be a chilled water precision air handling unit with chilled water cooling coil and chilled water control valve.

The chilled water cooling coil shall be constructed of copper tubes and aluminum fins. Coil end-plates shall be hot dipped galvanized. The cooling coil shall be mounted in an insulated stainless steel condensate drain pan.

Chilled water flow shall be controlled by a factory installed slowly opening and closing 2-way motorized valve rated for a maximum 300 psig w.w.p.

(Note: 3-way, Modulating (0-10Vdc) & Higher Pressure valves are optionally available.)

Options

DX Air Cooled Condenser - Low Ambient Control

0°F Ambient - Fan Cycling (CCX, XP1 & XPU Models)

Fan cycling controls shall be factory installed to the direct drive condenser fan to allow for low ambient operation to 0°F.

-20°F Ambient - Variable Spd Fan (XCU, XP1 & XPU Models)

Variable fan speed head pressure controls (*JCI P266 or VFD66*) shall be factory installed to allow for low ambient operation to -20°F. Compressor cold start time delay relay and crankcase heater shall be factory installed with the -20°F low ambient control feature.

-30°F Flooded Condenser (All Condensing/er Models)

A flooded condenser system shall be provided to allow for low ambient condenser operation to -30°F. The flooded system shall include a factory installed liquid refrigerant receiver and modulating head pressure control valve. Compressor cold start time delay relay and crankcase heater shall be factory installed with the -30°F low ambient control feature.

DX - Water / Glycol Cooled Head Pressure Control

DX - Water/Glycol Reg. Valves (Factory Installed!)



- 2-Way, 150 psig Reg. Valve
- 3-Way, 150 psig Reg. Valve
- 2-Way, 350 psig Reg. Valve
- 3-Way, 350 psig Reg. Valve

System head pressure shall be controlled by a factory provided _____-way water / glycol regulating valve rated for _____ psig w.w.p.

Chilled Water Control Valves

Chilled Water Control Valves



Zone Valves, 2-Position ON/OFF:

- 2-Way, 300 psig (2-POS, ON/OFF, NC)
- 3-Way, 300 psig (2-POS, ON/OFF, NC)

Modulating Valves, 0-10Vdc:

(Requires MC-2000™)

- 2-Way, 300 psig (0-10Vdc, NC)
- 3-Way, 300 psig (0-10Vdc, NC)

A ___-way chilled water system control valve shall be factory installed within the air conditioning unit. The valve shall provide precision space cooling and/or dehumidification control. The valve shall be the 24 VAC, ___-Way, (2-Position ON/OFF or Modulating 0-10Vdc), normally closed type

Hot Gas Bypass Systems

Hot Gas Bypass To Evap Inlet



Each refrigerant circuit shall be provided with a factory installed hot gas (discharge) bypass valve. The hot gas bypass valve shall be designed to supply hot gas to evaporator inlet as required to provide coil freeze-protection and capacity modulation under low load conditions

Hot Gas Bypass To Suction Line with Quench Valve

(SPH/XPU-CCU/CWU-CGU Remote Condensing Units 3rd Line Not Required!)



Each refrigerant circuit of the Split DX system shall be provided with a factory installed hot gas bypass system to include: hot gas (discharge) bypass; desuperheating quench; and hot gas & quench solenoid valves. The hot gas bypass system shall be designed to supply hot gas and liquid refrigerant to the suction line as required to provide coil freeze-protection and capacity modula-

tion under low load conditions. All hot gas bypass components shall be factory installed and shall not require additional field refrigerant lines on split DX systems.

Suction-Line Accumulator



Each refrigerant circuit shall be provided with a factory installed Suction-Line Accumulator to prevent liquid slugging of the compressor and excessive refrigerant dilution of the compressor oil during low load conditions. The accumulator shall return refrigerant and oil to the compressor at a sufficient rate to maintain both system operating efficiency and proper oil level. The accumulators shall be wrapped with 1/2" closed-cell neoprene insulation to prevent sweating.

CONTROL OPTIONS

DT-201™ - Digital H/C Thermostat (7-day programmable)



Honeywell TH6000
(AC or HP w/o BacNet)

A remote wall mounted deluxe 7-day programmable heat pump ready thermostat with digital display shall be factory provided for field installation. The thermostat shall include FAN AUTO-ON, AUTO-COOL-OFF-HEAT-EM (emergency heat), SET and PROG/MAN selector switches.

MC-2000™, Advanced Temp/Humid Microprocessor Controller w/ Alarms & BMS Connection



The system shall be provided with a MC-2000™ advanced microprocessor based temperature and humidity controller with alarms.

Select Features/Benefits:

- 4x20 Character Liquid Crystal Alpha-numerical Display

- User Configurable
- Run-Time Hours
- Current Unit Mode Status
- Alarm Status
- Digital & Analog Inputs / Outputs
- Temperature Anticipation
- Remote Stop / Start Contact
- Summary Alarm Contact
- Automatic or Manual (selectable) Restart After Power Loss
- Sequential Load After Restart
- Recovery Delay
- Compressor Short Cycle Timers
- Cold Start Time Delay
- Security Password Access
- Self-Diagnostics
- Service Mode

Unit Status Display

The control system shall display current unit functions and room status (if applicable):

- Current Dry Bulb Temp Set Point
- Current Relative Humidity Set Point
- System ON/OFF
- Cooling
- Heating
- Humidifying
- Dehumidifying
- Reheating
- Actual Room DB Temperature
- Actual Room Relative Humidity

Alarm Conditions:

Alarm conditions activate an audible and visual indicator plus close a summary alarm dry contact connection. The control system shall alert to the following alarm conditions (if applicable):

- High Temperature
- Low Temperature
- High Humidity
- Low Humidity
- Sensor Failure
- Summary Failure
- Loss of Air Flow
- High Head Press
- Smoke Detection
- Firestat
- Leak Detection
- Sensor Failure
- Loss of Power
- Dirty Filter

Digital & Analog Control Inputs / Outputs:

The control system shall be capable of both digital (ON/OFF) and analog (proportional integral, PI) input and output control.

Select MC-2000 Options:

- Multi-Unit N+1 Sequencing
- BMS Communications Interface:
 - BACnet over MS/TP (RS485 Serial)
 - BACnet Over IP (Ethernet / EIA485)
 - ModBus RS485 Serial Connection

Heat / Reheat Options

Electric Reheat/Heat



An electric heating system shall be factory installed to provide:

- Electric Heat Only during heat mode
- Electric Reheat to offset sensible cooling during the dehumidification mode and to provide heating during heat mode.

Heater elements shall be the low-watt density finned-tubular type. The heater shall be complete with individual heater stage starter/contacter and overheat safeties. Systems incorporating factory installed electric heaters shall require only single point power to the main unit power distribution. The electric heat shall have a capacity of _____ BTU/H and a KW rating of ___ KW, controlled in ___ stages.

SCR Fired Heat/Reheat (Requires MC-2000™)

The electric heat/reheat shall be controlled through a "zero firing" silicon control rectifier (SCR) with an extruded aluminum heat sink and solid state logic system to provide close dry bulb temperature control of the leaving conditioned air temperature. The electric heat shall have a capacity of _____ BTUH and a KW rating of ___ KW.

Hot Gas Reheat



The system shall be provided with a hot gas reheat coil with 3-way heat reclaim control valve. The hot gas reheat coil shall provide free-energy space neutral leaving air temperature by offsetting the sensible cooling during dx dehumidification operation.

(Note: When compressor is located in the remote condensing unit, the maximum allowable refrigerant run for systems with Hot Gas Reheat is 40 linear feet, including both horizontal and vertical refrigerant line components.)

Humidification Options

Steam Canister Humidification (Requires MC-2000™)



An electrode steam canister type humidification system shall be factory installed within the air conditioning system. The humidifier shall be complete with disposable canister, steam distributor, fill and drain valve, air gap, automatic flush cycle, manual humidity output adjustment and field installed remote wall mounted humidistat. The humidifier shall have a maximum output capacity of _____ lbs/hr.

Accessories

Condensate Pump



A condensate pump shall be factory provided for field installation. The condensate pump shall be provided with dual internal float switches: one for pump operation initiation and the other for pump reservoir overflow safety. The condensate pump shall require a separate main power supply.

(Note: Plenum Rated Condensate Pumps are optionally available!)

Main Power, Non-Fused Disconnect



A main power non-fused disconnect shall be factory provided for field installation. The disconnect shall be NEMA rated for indoor or outdoor installation as required.

Remote Water-Leak Detector



A remote water-leak detector shall be

factory provided for field installation. The remote water-leak detector shall be wired to shut down all A/C unit water producing functions upon sensing a water leak.

Flow Switch - Condenser Water



A factory installed flow switch shall shut-down / lockout compressor operation prior to a high refrigerant pressure switch alarm upon sensing a loss or low dx condenser water/glycol flow. The flow switch alarm shall be indicated both via MC-2000 microprocessor display and auxiliary dry-contact terminal connection.

Low Entering Condenser Water / Glycol Kit to 45°F EWT/EGT

A low enter condenser water/glycol kit shall be provided with liquid refrigerant receiver, compressor crankcase heater, insulated wrapped coaxial condenser and unit internal condenser water/glycol piping. The Low EWT/EGT kit shall allow for continued winter A/C operation when condenser source water/glycol drops below 65°F (down to 45°F).

Firestat



A Firestat shall be factory provided for field installation in the return air duct and wired to the A/C unit electrical control panel. The Firestat shall shut-down all A/C system operations upon sensing a high return air temperature condition.

Smoke Detector - Factory Installed



A Smoke Detector shall be factory installed in the return air stream of the unit and wired to the A/C unit electrical control panel. The Smoke Detector shall shut-down all A/C system operations upon activation.

Free-Cooling Water/Glycol-Side Economizer Coil



The system shall include a factory installed water/glycol free cooling cycle complete with economizer cooling coil, aquastat, automatic control logic and field installed 3-way control valve. The FE coil shall be capable of providing rated sensible capacity without compressor operation when entering water/glycol fluid temperatures are 45°F or below.

(Note: 2-way DX/FE valve configurations are optionally available.)

Hanging / Mounting Isolators

Rubber/Cork Anti-Vibration Pads:



Each indoor horizontal ceiling mounted A/C shall be provided with a set of quantity four (4"x4"x7/8") Rubber/Cork Anti-Vibration Pad vibration mounting isolators.

Hanging Spring Isolators



Each horizontal ceiling mounted section shall be provided with spring vibration hanging isolators sized for the total distributive weight of the unit.

Hose Kits - Automatic



Condenser water/glycol hose kits shall be factory provided. Each kit shall include the piping specialties necessary to ensure a proper installation: a Hays

2500 Series Mesurflo Automatic Flow Control Valve, two 36" flexible hoses, ball valves on the return and supply sides with P/T Ports, high flow "Y-ball" strainers for sizes 1/2"-2" and a manual air vent on the return. Hose materials shall be the reinforced and bonded EPDM rubber type with a temperature rating of 32°F to 225°F and a working pressure of 400 psig. Minimum burst pressure shall be four (4) times the working pressure at maximum rated temperature. The hoses shall have stainless steel braid over an EPDM liner. The "Y-Ball" strainers shall have a stainless steel 20 mesh screen that is easily accessible for cleaning without disconnecting the hoses.

Compressor Sound Jacket



Each compressor shall be provided with a factory installed compressor sound jacket with a snap closure system for ease of removal and reinstallation. Sound jackets shall have a noise reduction coefficient (NRC) of 0.85 per ASTM (C423) and a sound transmission class/loss (STC) of 11 per ASTM E-90.

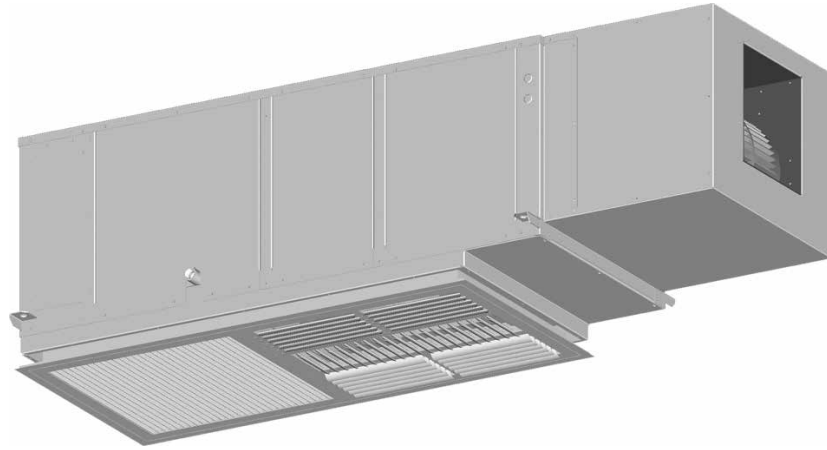

DX & CW System
“Spot-Cooler & Ducted”

Blank Page!

Performance Data (SC™ 2x4) - DX 4-11kW (1-3 Tons)

Nominal Size		4kW (1.0 Ton)	5kW (1.5 Tons)	7kW (2.0 Tons)	9kW (2.5 Tons)	11kW (3.0 Tons)
AIR COOLED DX						
Air Cooled Model		SCA, SCE & SCH-012	SCA, SCE & SCH-018	SCA, SCE & SCH-024	SCA, SCE & SCH-030	SCA, SCE & SCH-036
80°F DB / 67°F WB, 50% RH						
Total	BTUH	13,900	20,000	25,300	33,700	37,000
Sensible	BTUH	10,200	16,200	18,400	23,100	26,200
75°F DB / 62.5°F WB, 50% RH						
Total	BTUH	13,100	18,300	22,900	31,000	33,700
Sensible	BTUH	10,600	15,900	18,400	22,800	25,400
72°F DB / 60°F WB, 50% RH						
Total	BTUH	12,500	17,400	22,100	29,500	32,100
Sensible	BTUH	10,400	15,600	19,100	22,500	24,700
Water Cooled Model		SCW-012	SCW-018	SCW-024	SCW-030	SCW-036
80°F DB / 67°F WB, 50% RH						
Total	BTUH	14,700	20,000	26,800	35,900	39,300
Sensible	BTUH	10,200	16,700	19,100	24,400	27,400
75°F DB / 62.5°F WB, 50% RH						
Total	BTUH	13,800	19,400	24,400	33,000	35,900
Sensible	BTUH	10,400	16,400	18,900	24,200	26,600
72°F DB / 60°F WB, 50% RH						
Total	BTUH	13,300	18,400	23,200	31,500	34,200
Sensible	BTUH	10,800	16,000	18,600	23,800	25,900
Glycol Cooled Model		SCG-012	SCG-018	SCG-024	SCG-030	SCG-036
80°F DB / 67°F WB, 50% RH						
Total	BTUH	13,600	19,000	24,000	33,000	35,300
Sensible	BTUH	10,400	15,800	18,300	23,200	25,400
75°F DB / 62.5°F WB, 50% RH						
Total	BTUH	12,500	17,400	23,100	30,300	32,200
Sensible	BTUH	10,400	15,500	18,400	22,900	24,700
72°F DB / 60°F WB, 50% RH						
Total	BTUH	11,900	16,600	22,000	28,900	30,400
Sensible	BTUH	10,100	15,200	19,000	22,500	24,500

GENERAL SHARED DATA

Electric Reheat / Heat - BTUH includes evaporator motor heat, (Optional)						
Capacity @ 208V	BTUH (KW)	16,040 (4.7)	16,040 (4.7)	16,610 (4.9)	16,610 (4.9)	17,185 (5.0)
Capacity @ 230V	BTUH (KW)	17,675 (5.2)	17,675 (5.2)	18,245 (5.3)	18,245 (5.3)	18,820 (5.5)
Capacity @ 460V	BTUH (KW)	16,960 (5.0)	16,960 (5.0)	17,535 (5.1)	17,535 (5.1)	18,105 (5.3)
Cap. @ 277/480V	BTUH (KW)	17,675 (5.2)	17,675 (5.2)	18,245 (5.3)	18,245 (5.3)	18,820 (5.5)
Hot Gas Reheat - (Optional)						
Capacity	BTUH	12,690	18,210	21,350	26,060	30,125
Steam Canister Humidifier - (Optional)						
Steam Canister	LBS/HR	5	5	5	5	5
Evaporator Blower / Motor - Direct Drive, DWDI Centrifugal						
Airflow Rate	CFM	500	750	900	1,000	1,200
E.S.P.	IN WG	0.3	0.3	0.3	0.3	0.3
Blower Motor	HP	1/4	1/4	1/2	1/2	3/4
Evaporator Coil - Aluminum Fin, Copper Tube						
Rows / Face Area	NO / FT²	3 / 2.0	3 / 2.0	3 / 2.0	3 / 2.5	3 / 2.5
Filters - 20% Dust Spot Efficient (Spot Cooler Version)						
Nominal Size	(NO) IN	(1) 20 x 20 x 1	(1) 20 x 20 x 1	(1) 20 x 20 x 1	(1) 20 x 20 x 1	(1) 20 x 20 x 1
Compressor - Heat Pump Duty Scroll						
Qty., Horespower	(NO) HP	(1) 1.25	(1) 1.5	(1) 2.0	(1) 2.5	(1) 3.0
Connection Sizes						
Condensate Drain	FPT IN	3/4	3/4	3/4	3/4	3/4
Humidifier Inlet	OD IN	1/4	1/4	1/4	1/4	1/4

Performance Data (SC™ 2x4) DX 4-11kW (1-3 Tons)

Heat Rejection Data

Nominal Size Model Size	4kW (1.0 Ton) 012	5kW (1.5 Tons) 018	7kW (2.0 Tons) 024	9kW (2.5 Tons) 030	11kW (3.0 Tons) 036
----------------------------	----------------------	-----------------------	-----------------------	-----------------------	------------------------

DX - AIR COOLED CONDENSER DATA

AIR COOLED DX

Indoor, Integral or Remote Centrifugal Blower Air Cooled Condenser & Condensing Unit Data - (SCA, CCU & CCX Models)						
Integral, Self-Contained Model	SCA-012	SCA-018	SCA-024	SCA-030	SCA-036	
Remote Condensing Unit Model	CCU-012	CCU-018	CCU-024	CCU-030	CCU-036	
Remote Condenser Model	CCX-012	CCX-018	CCX-014	CCX-030	CCX-036	
Airflow Rate	CFM	1,000	1,200	1,400	1,700	1,700
	IN ESP	0.3	0.3	0.3	0.3	0.3
Blower Motor	HP	1/2	1/2	3/4	3/4	3/4
Blower Type		DD - Centrifugal	DD - Centrifugal	DD - Centrifugal	DD - Centrifugal	DD - Centrifugal
Coil Face Area	FT ²	2.0	2.0	2.0	2.5	2.5
Rows	NO	4	4	4	4	4
Outdoor, Remote Propeller Fan Air Cooled Condensing Units & Condensers - (XPU & XP1 models)						
Remote Condensing Unit Model	XPU-012	XPU-018	XPU-024	XPU-030	XPU-036	
Remote Condenser Model	XP1-012	XP1-018	XP1-024	XP1-030	XP1-036	
Airflow Rate	CFM	1,792	2,218	2,218	2,954	3,167
	IN ESP	Free Discharge	Free Discharge	Free Discharge	Free Discharge	Free Discharge
Fan Motor	(NO) HP	(1) 1/6	(1) 1/6	(1) 1/6	(1) 1/6	(1) 1/4
Fan Type		DD - Propeller	DD - Propeller	DD - Propeller	DD - Propeller	DD - Propeller
Coil Face Area	FT ²	8.4	8.4	9.8	13.13	17.25
Rows	NO	1	1	1	1	1

DX - WATER COOLED CONDENSER DATA

WATER COOLED DX

Water Cooled Condenser Data - (SCW & CWU models)						
Model	SCW-012	SCW-018	SCW-024	SCW-030	SCW-036	
Total Heat of Rej.	BTUH	21,575	24,270	32,315	43,100	47,410
Flow @ 85°F EWT	GPM	4.3	4.9	6.5	8.6	9.5
Water Press. Drop	FT WG	7.8	9.8	11.4	14.5	15.2
Water Reg. Valve		2-Way, 150 psig - factory installed, (3-way & High Pressure Optional)				

DX - GLYCOL COOLED CONDENSER DATA

GLYCOL COOLED DX

Glycol Cooled Condenser Data - Based on 40% Ethylene Glycol (SCG & CGU models)						
Model	SCG-012	SCG-018	SCG-024	SCG-030	SCG-036	
Total Heat of Rej.	BTUH	21,345	24,885	31,430	42,100	46,425
Flow @ 110°F EGT	GPM	4.7	5.5	7.0	9.3	10.3
Glycol Press. Drop	FT WG	9.3	12.4	13.1	16.3	17.8
Glycol Reg. Valve		2-Way, 150 psig - factory installed, (3-way & High Pressure Optional)				

Connection Data

Nominal Size Model Size	4kW (1.0 Ton) 012	5kW (1.5 Tons) 018	7kW (2.0 Tons) 024	9kW (2.5 Tons) 030	11kW (3.0 Tons) 036
----------------------------	----------------------	-----------------------	-----------------------	-----------------------	------------------------

DX - AIR COOLED REFRIGERANT (R410a) CONNECTION DATA

AIR COOLED

DX Split Air Handling Units & Indoor, Centrifugal Blower Remote Air Cooled Condensing Units - (SCH & CCU models)						
Liquid Line	OD IN	(1) 3/8	(1) 3/8	(1) 3/8	(1) 3/8	(1) 3/8
Suction Line	OD IN	(1) 3/4	(1) 3/4	(1) 3/4	(1) 3/4	(1) 7/8
DX Split Evaporators & Indoor Remote Centrifugal Air Cooled Condensers - (SCE & CCX models)						
Liquid Line	OD IN	(1) 3/8	(1) 3/8	(1) 3/8	(1) 3/8	(1) 3/8
Hot Gas Line	OD IN	(1) 1/2	(1) 1/2	(1) 1/2	(1) 1/2	(1) 1/2
Outdoor, Propeller Fan Remote Air Cooled Condensers & Condensing Units - (XP1 w/ Liquid & Hot Gas Lines and XPU w/ Liquid & Suction Lines)						
Liquid Line	OD IN	(1) 3/8	(1) 3/8	(1) 3/8	(1) 3/8	(1) 3/8
Suction or Hot Gas Line	OD IN	(1) 3/4	(1) 3/4	(1) 3/4	(1) 3/4	(1) 7/8

DX - WATER COOLED CONDENSER CONNECTION DATA

WATER / GLYCOL COOLED

Water / Glycol Cooled Condenser Data - (SCW, SCG, CWU & CGU models)						
Water/Glycol IN/OUT	OD IN	5/8	5/8	5/8	7/8	7/8

Performance Data (SC™ 2x4) - Chilled Water 4-11kW (1-3 Tons)

**CHILLED
WATER
SYSTEMS**

Nominal Size		4kW (1.0T)	5kW (1.5T)	7kW (2.0T)	9kW (2.5T)	11kW (3.0T)
Chilled Water Unit Model		SCC-012	SCC-018	SCC-024	SCC-030	SCC-036
Cooling Capacity - 45°F Entering Chilled Water (0% Glycol)						
80°F DB / 67°F WB, 50% RH						
Total	BTUH	14,400	21,900	26,900	36,600	41,400
Sensible	BTUH	10,800	16,900	20,400	25,400	29,300
75°F DB / 62.5°F WB, 50% RH						
Total	BTUH	11,500	17,600	21,500	28,700	32,600
Sensible	BTUH	10,000	15,800	18,900	23,100	26,700
72°F DB / 60°F WB, 50% RH						
Total	BTUH	10,000	15,400	18,700	24,600	28,000
Sensible	BTUH	9,400	14,900	17,800	21,500	25,000
Chilled Water Coil / Valve - Aluminum Fin, Copper Tube						
Flow Rate / Coil PD	GPM/FT	3.0 / (0.5)	4.5 / (1.0)	6.0 (1.9)	7.3 (11.1)	8.3 / (13.9)
Rows / Face Area	NO / FT²	4 / 2.0	4 / 2.0	4 / 2.0	4 / 2.5	4 / 2.5
Standard Valve	BTUH	2-Way, 300 psig - factory installed, (3-Way & Higher Pressure Optional)				
Evaporator Blower / Motor - Direct Drive, DWDI Centrifugal						
Airflow Rate @ E.S.P.	CFM / IN WG	500 @ 0.3	750 @ 0.3	900 @ 0.3	1,000 @ 0.3	1,200 @ 0.3
Blower Motor	HP	1/4	1/4	1/2	1/2	3/4
Electric Reheat / Heat - BTUH includes evaporator motor heat, (Optional)						
Capacity @ 208V	BTUH (KW)	16,040 (4.7)	16,040 (4.7)	16,610 (4.9)	16,610 (4.9)	17,185 (5.0)
Capacity @ 230V	BTUH (KW)	17,675 (5.2)	17,675 (5.2)	18,245 (5.3)	18,245 (5.3)	18,820 (5.5)
Capacity @ 460V	BTUH (KW)	16,960 (5.0)	16,960 (5.0)	17,535 (5.1)	17,535 (5.1)	18,105 (5.3)
Capacity @ 277/480V	BTUH (KW)	17,675 (5.2)	17,675 (5.2)	18,245 (5.3)	18,245 (5.3)	18,820 (5.5)
Steam Canister Humidifier - (Optional)						
Steam Canister	LBS/HR	5	5	5	5	5
Filters - 20% Dust Spot Efficient (Spot Cooler Version)						
Nominal Size	(NO) IN	(1) 20 x 20 x 1	(1) 20 x 20 x 1	(1) 20 x 20 x 1	(1) 20 x 20 x 1	(1) 20 x 20 x 1
Connection Sizes						
Chilled Water In/Out	OD IN	5/8	5/8	5/8	7/8	7/8
Condensate Drain	FPT IN	3/4	3/4	3/4	3/4	3/4
Humidifier Inlet	OD IN	1/4	1/4	1/4	1/4	1/4

DX - Air Cooled, Self-Contained

MODEL	SCA-012S		SCA-018S		SCA-024S				SCA-030S				SCA-036S			
Power Supply	208/1/60	277/1/60	208/1/60	277/1/60	208/1/60	277/1/60	208/3/60	460/3/60	208/1/60	277/1/60	208/3/60	460/3/60	208/1/60	277/1/60	208/3/60	460/3/60
Cooling Only (or Cooling with Hot Gas Reheat)																
FLA	15.8	12.2	15.8	12.2	20.8	15.0	15.7	6.9	22.2	17.0	17.7	8.8	27.5	21.3	21.2	10.8
MCA	18.2	14.1	18.2	14.1	24.0	17.4	17.6	7.8	25.4	19.7	19.8	10.1	31.6	24.6	23.9	12.2
MOP	25	20	25	20	35	25	25	15	35	30	25	15	45	35	30	15
with Electric Heat (No Electric Reheat or Humidifier)																
FLA	26.3	19.4	26.3	19.4	28.1	20.3	17.9	7.8	28.1	20.3	17.9	8.8	29.5	22.0	21.2	10.8
MCA	32.9	24.2	32.9	24.2	35.1	25.4	22.4	9.7	35.1	25.4	22.4	10.1	36.9	27.5	24.1	12.2
MOP	35	25	35	25	40	30	25	15	40	30	25	15	45	35	30	15
with Electric Reheat/Heat (No Humidifier)																
FLA	39.9	30.3	39.9	30.3	44.9	33.1	29.6	13.2	46.3	35.1	31.6	15.1	51.6	39.3	35.2	17.1
MCA	48.3	36.7	48.3	36.7	54.1	40.0	35.0	15.6	55.5	42.3	37.2	18.0	61.7	47.2	41.2	20.1
MOP	50	40	50	40	60	45	35	20	60	45	40	20	70	50	45	25
with Humidifier with or without Hot Gas Reheat (No Electric Reheat/Heat)																
FLA	24.0	18.4	24.0	18.4	29.0	21.2	23.9	10.6	30.4	23.2	25.9	12.5	35.7	27.5	29.4	14.5
MCA	26.4	20.3	26.4	20.3	32.2	23.6	25.8	11.5	33.6	25.9	28.0	13.8	39.8	30.8	32.1	15.9
MOP	35	25	35	25	45	30	30	15	45	35	35	15	50	40	40	20
with Electric Heat (No Electric Reheat) & Humidifier																
FLA	34.5	25.6	34.5	25.6	36.3	26.5	26.1	11.5	36.3	26.5	26.1	12.5	37.7	28.2	29.4	14.5
MCA	41.1	30.4	41.1	30.4	43.3	31.6	30.6	13.4	43.3	31.6	30.6	13.8	45.1	33.7	32.3	15.9
MOP	45	35	45	35	45	35	35	15	45	35	35	15	50	40	40	20
with Electric Reheat/Heat & Humidifier																
FLA	39.9	30.3	39.9	30.3	44.9	33.1	29.6	13.2	46.3	35.1	31.6	15.1	51.6	39.3	35.2	17.1
MCA	48.3	36.7	48.3	36.7	54.1	40.0	35.0	15.6	55.5	42.3	37.2	18.0	61.7	47.2	41.2	20.1
MOP	50	40	50	40	60	45	35	20	60	45	40	20	70	50	45	25

DX Split Evap & DX - Water/Glycol Cooled Self-Contained

MODEL	SCE/W/G-012S		SCE/W/G-018S		SCE/W/G-024S				SCE/W/G-030S				SCE/W/G-036S			
Power Supply	208/1/60	277/1/60	208/1/60	277/1/60	208/1/60	277/1/60	208/3/60	460/3/60	208/1/60	277/1/60	208/3/60	460/3/60	208/1/60	277/1/60	208/3/60	460/3/60
Cooling Only (or Cooling with Hot Gas Reheat)																
FLA	11.8	9.0	11.8	9.0	16.8	11.8	11.7	5.1	16.8	13.1	12.3	6.6	22.1	17.4	15.8	8.6
MCA	14.2	10.9	14.2	10.9	20.0	14.2	13.6	6.0	20.0	15.8	14.4	7.9	26.2	20.7	18.5	10.0
MOP	20	15	20	15	30	20	20	15	30	25	20	15	40	30	25	15
with Electric Heat (No Electric Reheat or Humidifier)																
FLA	26.3	19.4	26.3	19.4	28.1	20.3	17.9	7.8	28.1	20.3	17.9	7.8	29.5	22.0	19.3	9.1
MCA	32.9	24.2	32.9	24.2	35.1	25.4	22.4	9.7	35.1	25.4	22.4	9.7	36.9	27.5	24.1	11.4
MOP	35	25	35	25	40	30	25	15	40	30	25	15	40	30	25	15
with Electric Reheat/Heat (No Humidifier)																
FLA	35.9	27.1	35.9	27.1	40.9	29.9	25.6	11.4	40.9	31.2	26.2	12.9	46.2	35.4	29.8	14.9
MCA	44.3	33.5	44.3	33.5	50.1	36.8	31.0	13.8	50.1	38.4	31.8	15.8	56.3	43.3	35.8	17.9
MOP	45	35	45	35	60	40	35	15	60	40	35	20	60	50	40	20
with Humidifier with or without Hot Gas Reheat (No Electric Reheat/Heat)																
FLA	20.0	15.2	20.0	15.2	25.0	18.0	19.9	8.8	25.0	19.3	20.5	10.3	30.3	23.6	24.0	12.3
MCA	22.4	17.1	22.4	17.1	28.2	20.4	21.8	9.7	28.2	22.0	22.6	11.6	34.4	26.9	26.7	13.7
MOP	30	20	30	20	40	30	25	15	40	30	30	15	50	40	35	15
with Electric Heat (No Electric Reheat) & Humidifier																
FLA	34.5	25.6	34.5	25.6	36.3	26.5	26.1	11.5	36.3	26.5	26.1	11.5	37.7	28.2	27.5	12.8
MCA	41.1	30.4	41.1	30.4	43.3	31.6	30.6	13.4	43.3	31.6	30.6	13.4	45.1	33.7	32.3	15.1
MOP	45	35	45	35	45	35	35	15	45	35	35	15	50	40	35	20
with Electric Reheat/Heat & Humidifier																
FLA	35.9	27.1	35.9	27.1	40.9	29.9	26.1	11.5	40.9	31.2	26.2	12.9	46.2	35.4	29.8	14.9
MCA	44.3	33.5	44.3	33.5	50.1	36.8	31.0	13.8	50.1	38.4	31.8	15.8	56.3	43.3	35.8	17.9
MOP	45	35	45	35	60	40	35	15	60	40	35	20	60	50	40	20

Notes:

- 1) FLA = Full Load Amps; MCA = Min Circuit Amps; MOP = Max Overcurrent Protection (Max Fuse Size)
- 2) 277/1/60 systems may require factory provided field installed step-down transformer.
- 3) - - - - Consult local AboveAir Sales Representative for non-cataloged system power supply information.

DX Split and Chilled Water - Air Handling Units

MODEL	SCC/H-012		SCC/H-018		SCC/H-024				SCC/H-030				SCC/H-036			
Power Supply	208/1/60	277/1/60	208/1/60	277/1/60	208/1/60	277/1/60	208/3/60	460/3/60	208/1/60	277/1/60	208/3/60	460/3/60	208/1/60	277/1/60	208/3/60	460/3/60
Cooling Only																
FLA	2.2	2.8	2.2	1.3	4.0	2.2	4.0	1.5	4.0	2.2	4.0	1.5	5.4	3.9	5.4	2.8
MCA	2.8	1.6	2.8	1.6	5.0	2.8	5.0	1.9	5.0	2.8	5.0	1.9	6.8	4.9	6.8	3.5
MOP	15	15	15	15	15	15	15	15	15	15	15	15	15	15	15	15
with Electric Heat or Reheat/Heat (No Humidifier)																
FLA	26.3	19.4	26.3	19.4	28.1	20.3	17.9	7.8	28.1	20.3	17.9	7.8	29.5	22.0	19.3	9.1
MCA	32.9	24.2	32.9	24.2	35.1	25.4	22.4	9.7	35.1	25.4	22.4	9.7	36.9	27.5	24.1	11.4
MOP	35	25	35	25	40	30	25	15	40	30	25	15	40	30	25	15
with Electric Reheat/Heat (No Humidification)																
FLA	26.3	19.4	26.3	19.4	28.1	20.3	17.9	7.8	28.1	20.3	17.9	7.8	29.5	22.0	19.3	9.1
MCA	32.9	24.2	32.9	24.2	35.1	25.4	22.4	9.7	35.1	25.4	22.4	9.7	36.9	27.5	24.1	11.4
MOP	35	25	35	25	40	30	25	15	40	30	25	15	40	30	25	15
with Humidifier (No Electric Reheat/Heat)																
FLA	10.4	7.5	10.4	7.5	12.2	8.4	12.2	5.2	12.2	8.4	12.2	5.2	13.6	10.1	13.6	6.5
MCA	11.0	7.8	11.0	7.8	13.2	9.0	13.2	5.6	13.2	9.0	13.2	5.6	15.0	11.1	15.0	7.2
MOP	15	15	15	15	15	15	15	15	15	15	15	15	20	15	20	15
with Electric Heat (No Electric Reheat) & Humidifier																
FLA	34.5	25.6	34.5	25.6	36.3	26.5	26.1	11.5	36.3	26.5	26.1	11.5	37.7	28.2	27.5	12.8
MCA	41.1	30.4	41.1	30.4	43.3	31.6	30.6	13.4	43.3	31.6	30.6	13.4	45.1	33.7	32.3	15.1
MOP	45	35	45	35	45	35	35	15	45	35	35	15	50	35	35	20
with Electric Heat or Electric Reheat/Heat & Humidifier																
FLA	34.5	25.6	34.5	25.6	36.3	26.5	26.1	11.5	36.3	26.5	26.1	11.5	37.7	28.2	27.5	12.8
MCA	41.1	30.4	41.1	30.4	43.3	31.6	30.6	13.4	43.3	31.6	30.6	13.4	45.1	33.7	32.3	15.1
MOP	45	35	45	35	45	35	35	15	45	35	35	15	50	35	35	20

Electrical Component Data - SC 2x4

Unit Size (Tons)	SC 2x4 Model	Main Power Supply	Compressor (Fixed Speed)				Evap Fan Motor				Cond Fan Motor (Indoor Centrifugal)			
			Qty.	RLA	LRA	Type	Qty.	FLA	HP	Type	Qty.	FLA	HP	Type
4kW (1.0 Ton)	SC_-012_-1	208/1/60	1	9.0	48.0	Scroll	1	2.2	1/4	PSC	1	4.0	1/2	PSC
	SC_-012_-7	277/1/60	1	7.1	43.0	Scroll	1	1.3	1/4	PSC	1	1.9	1/2	PSC
5kW (1.5 Tons)	SC_-018_-1	208/1/60	1	9.0	48.0	Scroll	1	2.2	1/4	PSC	1	4.0	1/2	PSC
	SC_-018_-7	277/1/60	1	7.1	43.0	Scroll	1	1.3	1/4	PSC	1	1.9	1/2	PSC
7kW (2.0 Tons)	SC_-024_-1	208/1/60	1	12.8	58.3	Scroll	1	4.0	1/2	PSC	1	5.4	3/4	PSC
	SC_-024_-7	277/1/60	1	9.6	54.0	Scroll	1	1.9	1/2	PSC	1	3.9	3/4	PSC
	SC_-024_-3	208/3/60	1	7.7	55.4	Scroll	1	4.0	1/2	PSC	1	5.4	3/4	PSC
	SC_-024_-4	460/3/60	1	3.6	28.0	Scroll	1	1.5	1/2	PSC	1	2.8	3/4	PSC
9kW (2.5 Tons)	SC_-030_-1	208/1/60	1	12.8	64.0	Scroll	1	4.0	1/2	PSC	1	5.4	3/4	PSC
	SC_-030_-7	277/1/60	1	10.9	60.0	Scroll	1	1.9	1/2	PSC	1	3.9	3/4	PSC
	SC_-030_-3	208/3/60	1	8.3	58.0	Scroll	1	4.0	1/2	PSC	1	5.4	3/4	PSC
	SC_-030_-4	460/3/60	1	5.1	28.0	Scroll	1	1.5	1/2	PSC	1	2.8	3/4	PSC
11kW (3.0 Tons)	SC_-036_-1	208/1/60	1	16.7	79.0	Scroll	1	5.4	3/4	PSC	1	5.4	3/4	PSC
	SC_-036_-7	277/1/60	1	13.5	72.0	Scroll	1	3.9	3/4	PSC	1	3.9	3/4	PSC
	SC_-036_-3	208/3/60	1	10.4	73.0	Scroll	1	5.4	3/4	PSC	1	5.4	3/4	PSC
	SC_-036_-4	460/3/60	1	5.8	38.0	Scroll	1	2.8	3/4	PSC	1	2.8	3/4	PSC

Notes:

- 1) FLA = Full Load Amps; MCA = Min Circuit Amps; MOP = Max Overcurrent Protection (Max Fuse Size)
- 2) 277/1/60 systems may require factory provided field installed step-down transformer.
- 3) - - - - Consult local AboveAir Sales Representative for non-cataloged system power supply information.

**DX - AIR & WATER / GLYCOL COOLED
REMOTE CONDENSERS & CONDENSING UNITS**

Unit Size (Nominal)	Condenser / Cond Unit Model	Main Power Supply	Type	Compressor (Fixed Speed)				Cond Fan Motor				Unit Nameplate Data		
				Qty.	RLA	LRA	Type	Qty.	HP (kW)	FLA	Type	FLA	MCA	MOP
4kW (1.0 Ton)	XP1-012S-1*	208/1/60	Outdoor Pad/Roof Mtd	---	---	---	---	1	1/6 (0.12)	1.1	PSC	1.1	1.4	15
	XP1-012S-7*	277/1/60	Outdoor Pad/Roof Mtd	---	---	---	---	1	1/6 (0.12)	0.8	PSC	0.8	1.0	15
	XPU-012S-1*	208/1/60	Outdoor Pad/Roof Mtd	1	9.0	48.0	Scroll	1	1/6 (0.12)	1.1	PSC	10.1	12.4	20
	XPU-012S-7*	277/1/60	Outdoor Pad/Roof Mtd	1	7.1	43.0	Scroll	1	1/6 (0.12)	0.8	PSC	7.9	9.7	15
	CCX-012S-1*	208/1/60	Indoor Ceiling Mtd	---	---	---	---	1	1/2 (0.37)	4.0	PSC	4.0	5.0	15
	CCX-012S-7*	277/1/60	Indoor Ceiling Mtd	---	---	---	---	1	1/2 (0.37)	2.2	PSC	2.2	2.8	15
	CCU-012S-1*	208/1/60	Indoor Ceiling Mtd	1	9.0	48.0	Scroll	1	1/2 (0.37)	4.0	PSC	13.0	15.3	20
	CCU-012S-7*	277/1/60	Indoor Ceiling Mtd	1	7.1	43.0	Scroll	1	1/2 (0.37)	2.2	PSC	9.3	11.1	15
	CWU/CGU-012S-1*	208/1/60	Indoor Ceiling Mtd	1	9.0	48.0	Scroll	---	---	---	---	9.0	11.3	20
	CWU/CGU-012S-7*	277/1/60	Indoor Ceiling Mtd	1	7.1	43.0	Scroll	---	---	---	---	7.1	8.9	15
5kW (1.5 Tons)	XP1-018S-1*	208/1/60	Outdoor Pad/Roof Mtd	---	---	---	---	1	1/6 (0.12)	1.1	PSC	1.1	1.4	15
	XP1-018S-7*	277/1/60	Outdoor Pad/Roof Mtd	---	---	---	---	1	1/6 (0.12)	0.8	PSC	0.8	1.0	15
	XPU-018S-1*	208/1/60	Outdoor Pad/Roof Mtd	1	9.0	48.0	Scroll	1	1/6 (0.12)	1.1	PSC	10.1	12.4	20
	XPU-018S-7*	277/1/60	Outdoor Pad/Roof Mtd	1	7.1	43.0	Scroll	1	1/6 (0.12)	0.8	PSC	7.9	9.7	15
	CCX-018S-1*	208/1/60	Indoor Ceiling Mtd	---	---	---	---	1	1/2 (0.37)	4.0	PSC	4.0	5.0	15
	CCX-018S-7*	277/1/60	Indoor Ceiling Mtd	---	---	---	---	1	1/2 (0.37)	2.2	PSC	2.2	2.8	15
	CCU-018S-1*	208/1/60	Indoor Ceiling Mtd	1	9.0	48.0	Scroll	1	1/2 (0.37)	4.0	PSC	13.0	15.3	20
	CCU-018S-7*	277/1/60	Indoor Ceiling Mtd	1	7.1	43.0	Scroll	1	1/2 (0.37)	2.2	PSC	9.3	11.1	15
	CWU/CGU-018S-1*	208/1/60	Indoor Ceiling Mtd	1	9.0	48.0	Scroll	---	---	---	---	9.0	11.3	20
	CWU/CGU-018S-7*	277/1/60	Indoor Ceiling Mtd	1	7.1	43.0	Scroll	---	---	---	---	7.1	8.9	15
7kW (2.0 Tons)	XP1-024S-1*	208/1/60	Outdoor Pad/Roof Mtd	---	---	---	---	1	1/6 (0.12)	1.1	PSC	1.1	1.4	15
	XP1-024S-7*	277/1/60	Outdoor Pad/Roof Mtd	---	---	---	---	1	1/6 (0.12)	0.8	PSC	0.8	1.0	15
	XP1-024S-3*	208/3/60	N/A											
	XP1-024S-8*	460/1/60	Outdoor Pad/Roof Mtd	---	---	---	---	1	1/4 (0.19)	1.0	PSC	1.0	1.3	15
	XPU-024S-1*	208/1/60	Outdoor Pad/Roof Mtd	1	10.9	62.9	Scroll	1	1/6 (0.12)	1.1	PSC	12.0	14.7	25
	XPU-024S-7*	277/1/60	Outdoor Pad/Roof Mtd	1	8.2	47.2	Scroll	1	1/6 (0.12)	0.8	PSC	9.0	11.1	15
	XPU-024S-3*	208/3/60	Outdoor Pad/Roof Mtd	1	7.7	55.4	Scroll	1	1/6 (0.12)	1.1	PSC	8.8	10.7	15
	XPU-024S-4*	460/3/60	Outdoor Pad/Roof Mtd	1	3.6	28.0	Scroll	1	1/4 (0.19)	1.0	PSC	4.6	5.5	15
	CCX-024S-1*	208/1/60	Indoor Ceiling Mtd	---	---	---	---	1	3/4 (0.56)	5.4	PSC	5.4	6.8	15
	CCX-024S-7*	277/1/60	Indoor Ceiling Mtd	---	---	---	---	1	3/4 (0.56)	3.9	PSC	3.9	4.9	15
	CCX-024S-3*	208/3/60	N/A											
	CCX-024S-8*	460/1/60	Indoor Ceiling Mtd	---	---	---	---	1	3/4 (0.56)	2.8	PSC	2.8	3.5	15
	CCU-024S-1*	208/1/60	Indoor Ceiling Mtd	1	12.8	58.3	Scroll	1	3/4 (0.56)	5.4	PSC	18.2	21.4	30
	CCU-024S-7*	277/1/60	Indoor Ceiling Mtd	1	9.6	54.0	Scroll	1	3/4 (0.56)	3.9	PSC	13.5	15.9	25
	CCU-024S-3*	208/3/60	Indoor Ceiling Mtd	1	7.7	55.4	Scroll	1	3/4 (0.56)	5.4	PSC	13.1	15.0	20
	CCU-024S-3*	460/3/60	Indoor Ceiling Mtd	1	3.6	28.0	Scroll	1	3/4 (0.56)	2.8	PSC	6.4	7.3	15
	CWU/CGU-024S-1*	208/1/60	Indoor Ceiling Mtd	1	12.8	58.3	Scroll	---	---	---	---	12.8	16.0	25
	CWU/CGU-024S-7*	277/1/60	Indoor Ceiling Mtd	1	10.9	60.0	Scroll	---	---	---	---	10.9	13.6	20
CWU/CGU-024S-3*	208/3/60	Indoor Ceiling Mtd	1	7.7	55.4	Scroll	---	---	---	---	7.7	9.6	15	
CWU/CGU-024S-4*	460/3/60	Indoor Ceiling Mtd	1	3.6	28.0	Scroll	---	---	---	---	3.6	4.5	15	

Notes:

- 1) FLA = Full Load Amps; MCA = Min Circuit Amps; MOP = Max Overcurrent Protection (Max Fuse Size)
- 2) 277/1/60 systems may require factory provided field installed step-down transformer.
- 3) --- Consult local AboveAir Sales Representative for non-cataloged system power supply information.

DX - AIR & WATER / GLYCOL COOLED
REMOTE CONDENSERS & CONDENSING UNITS ... Continued from Page 17

Unit Size (Nominal)	Condenser / Cond Unit Model	Main Power Supply	Type	Compressor (Fixed Speed)				Cond Fan Motor			Unit Nameplate Data			
				Qty.	RLA	LRA	Type	Qty.	HP (kW)	FLA	Type	FLA	MCA	MOP
9kW (2.5 Tons)	XP1-030S-1*	208/1/60	Outdoor Pad/Roof Mtd	---	---	---	---	1	1/4 (0.19)	2.0	PSC	2.0	2.5	15
	XP1-030S-7*	277/1/60	Outdoor Pad/Roof Mtd	---	---	---	---	1	1/4 (0.19)	1.5	PSC	1.5	1.9	15
	XP1-030S-3*	208/3/60	N/A											
	XP1-030S-8*	460/1/60	Outdoor Pad/Roof Mtd	---	---	---	---	1	1/4 (0.19)	1.0	PSC	1.0	1.3	15
	XPU-030S-1*	208/1/60	Outdoor Pad/Roof Mtd	1	12.8	64.0	Scroll	1	1/4 (0.19)	2.0	PSC	14.8	18.0	30
	XPU-030S-7*	277/1/60	Outdoor Pad/Roof Mtd	1	9.6	48.1	Scroll	1	1/4 (0.19)	1.5	PSC	11.1	13.5	20
	XPU-030S-3*	208/3/60	Outdoor Pad/Roof Mtd	1	8.3	58.0	Scroll	1	1/4 (0.19)	2.0	PSC	10.3	12.4	20
	XPU-030S-4*	460/3/60	Outdoor Pad/Roof Mtd	1	5.1	28.0	Scroll	1	1/4 (0.19)	1.0	PSC	6.1	7.4	15
	CCX-030S-1*	208/1/60	Indoor Ceiling Mtd	---	---	---	---	1	3/4 (0.56)	5.4	PSC	5.4	6.8	15
	CCX-030S-7*	277/1/60	Indoor Ceiling Mtd	---	---	---	---	1	3/4 (0.56)	3.9	PSC	3.9	4.9	15
	CCX-030S-3*	208/3/60	N/A											
	CCX-030S-8*	460/1/60	Indoor Ceiling Mtd	---	---	---	---	1	3/4 (0.56)	2.8	PSC	2.8	3.5	15
	CCU-030S-1*	208/1/60	Indoor Ceiling Mtd	1	12.8	64.0	Scroll	1	3/4 (0.56)	5.4	PSC	18.2	21.4	30
	CCU-030S-7*	277/1/60	Indoor Ceiling Mtd	1	10.9	60.0	Scroll	1	3/4 (0.56)	3.9	PSC	14.8	17.5	25
	CCU-030S-3*	208/3/60	Indoor Ceiling Mtd	1	8.3	58.0	Scroll	1	3/4 (0.56)	5.4	PSC	13.7	15.8	20
	CCU-030S-4*	460/3/60	Indoor Ceiling Mtd	1	5.1	28.0	Scroll	1	3/4 (0.56)	2.8	PSC	7.9	9.2	15
	CWU/CGU-030S-1*	208/1/60	Indoor Ceiling Mtd	1	12.8	64.0	Scroll	---	---	---	---	12.8	16.0	25
	CWU/CGU-030S-7*	277/1/60	Indoor Ceiling Mtd	1	10.9	60.0	Scroll	---	---	---	---	10.9	13.6	20
CWU/CGU-030S-3*	208/3/60	Indoor Ceiling Mtd	1	8.3	58.0	Scroll	---	---	---	---	8.3	10.4	15	
CWU/CGU-030S-4*	460/3/60	Indoor Ceiling Mtd	1	5.1	28.0	Scroll	---	---	---	---	5.1	6.4	15	
11kW (3.0 Tons)	XP1-036S-1*	208/1/60	Outdoor Pad/Roof Mtd	---	---	---	---	1	1/4 (0.19)	2.0	PSC	2.0	2.5	15
	XP1-036S-7*	277/1/60	Outdoor Pad/Roof Mtd	---	---	---	---	1	1/4 (0.19)	1.5	PSC	1.5	1.9	15
	XP1-036S-3*	208/3/60	N/A											
	XP1-036S-8*	460/1/60	Outdoor Pad/Roof Mtd	---	---	---	---	1	1/4 (0.19)	1.0	PSC	1.0	1.3	15
	XPU-036S-1*	208/1/60	Outdoor Pad/Roof Mtd	1	16.7	79.0	Scroll	1	1/4 (0.19)	2.0	PSC	18.7	22.9	35
	XPU-036S-7*	277/1/60	Outdoor Pad/Roof Mtd	1	12.5	59.3	Scroll	1	1/4 (0.19)	1.5	PSC	14.0	17.2	25
	XPU-036S-3*	208/3/60	Outdoor Pad/Roof Mtd	1	10.4	73.0	Scroll	1	1/4 (0.19)	2.0	PSC	12.4	15.0	25
	XPU-036S-4*	460/3/60	Outdoor Pad/Roof Mtd	1	5.8	38.0	Scroll	1	1/4 (0.19)	1.0	PSC	6.8	8.3	15
	CCX-036S-1*	208/1/60	Indoor Ceiling Mtd	---	---	---	---	1	3/4 (0.56)	5.4	PSC	5.4	6.8	15
	CCX-036S-7*	277/1/60	Indoor Ceiling Mtd	---	---	---	---	1	3/4 (0.56)	3.9	PSC	3.9	4.9	15
	CCX-036S-3*	208/3/60	N/A											
	CCX-036S-8*	460/1/60	Indoor Ceiling Mtd	---	---	---	---	1	3/4 (0.56)	2.8	PSC	2.8	3.5	15
	CCU-036S-1*	208/1/60	Indoor Ceiling Mtd	1	16.7	79.0	Scroll	1	3/4 (0.56)	5.4	PSC	22.1	26.3	40
	CCU-036S-7*	277/1/60	Indoor Ceiling Mtd	1	13.5	72.0	Scroll	1	3/4 (0.56)	3.9	PSC	17.4	20.8	30
	CCU-036S-3*	208/3/60	Indoor Ceiling Mtd	1	10.4	73.0	Scroll	1	3/4 (0.56)	5.4	PSC	15.8	18.4	25
	CCU-036S-4*	460/3/60	Indoor Ceiling Mtd	1	5.8	38.0	Scroll	1	3/4 (0.56)	2.8	PSC	8.6	10.1	15
	CWU/CGU-036S-1*	208/1/60	Indoor Ceiling Mtd	1	16.7	79.0	Scroll	---	---	---	---	16.7	20.9	35
	CWU/CGU-036S-7*	277/1/60	Indoor Ceiling Mtd	1	13.5	72.0	Scroll	---	---	---	---	13.5	16.9	30
CWU/CGU-036S-3*	208/3/60	Indoor Ceiling Mtd	1	10.4	73.0	Scroll	---	---	---	---	10.4	13.0	20	
CWU/CGU-036S-4*	460/3/60	Indoor Ceiling Mtd	1	5.8	38.0	Scroll	---	---	---	---	5.8	7.3	15	

Notes:

- 1) FLA = Full Load Amps; MCA = Min Circuit Amps; MOP = Max Overcurrent Protection (Max Fuse Size)
- 2) 277/1/60 systems may require factory provided field installed step-down transformer.
- 3) ---- Consult local AboveAir Sales Representative for non-cataloged system power supply information.

Approximate Unit Ship Weights (lbs.)

UNIT SIZE (Nom. MBH)	MODEL TYPE								
	SCA	SCH	SCE	SCW/SCG	SCC	XPU	XP1	CCU	CWU/CWG
012	335	180	245	280	185	110	60	195	145
018	335	180	245	280	185	115	65	215	145
024	340	180	250	285	185	120	70	215	150
030	375	185	275	310	190	145	95	220	155
036	410	190	325	360	195	180	130	230	160

9kW (2.5T), Air Cooled, Self-Contained (Spot Cooler)

Models: SCA-030

2-Side Access:
18"-24" on Front & Rear Sides!

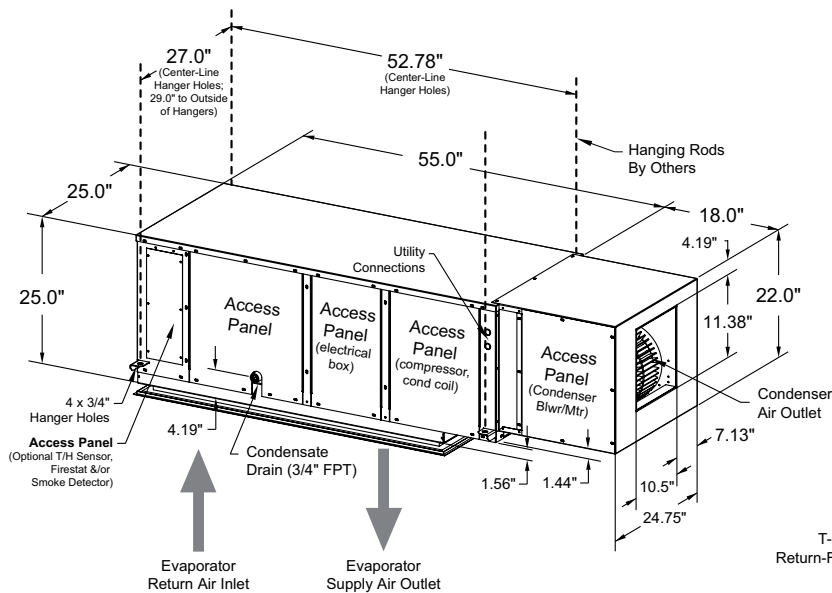

Front / Right / Top

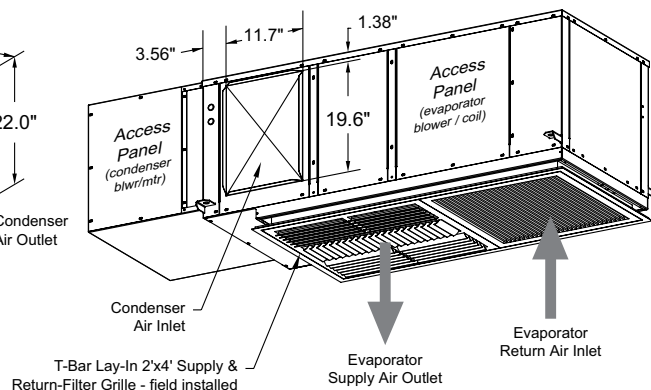

Rear / Left / Bottom

9kW (2.5T), Air Cooled, Self-Contained (Ducted Evap)

Models: SCA-030

2-Side Access:
18"-24" on Front & Rear Sides!

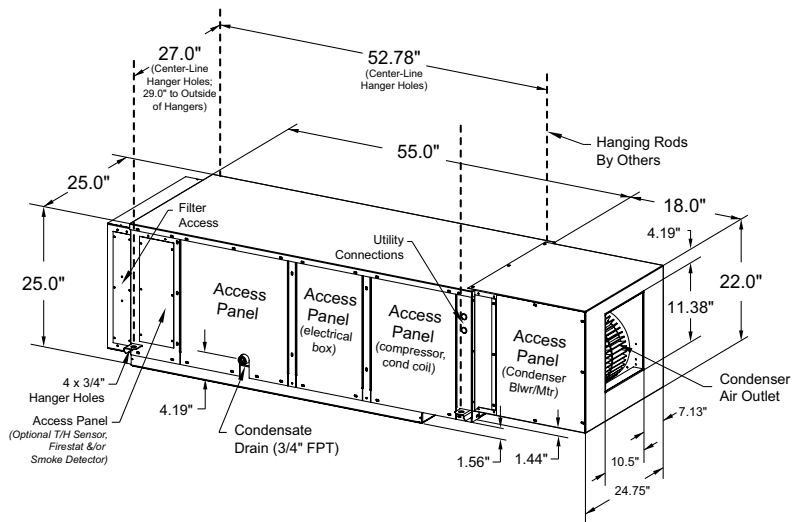

Front / Right / Top

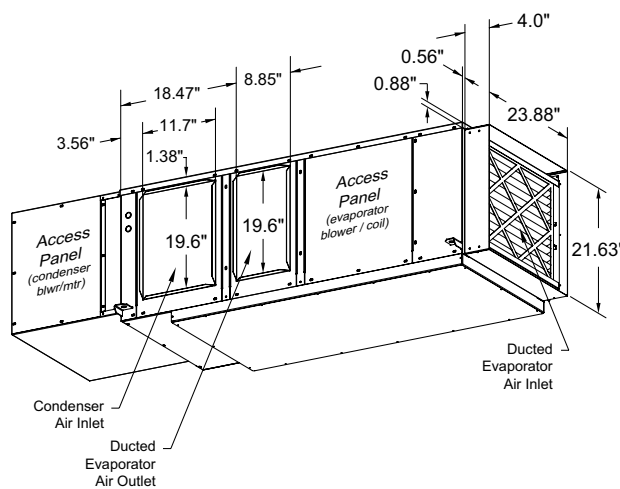

Rear / Left / Bottom

11kW (3T), Air Cooled, Self-Contained (Spot Cooler)

Models: SCA-036-__

2-Side Access:
18"-24" on Front & Rear Sides!

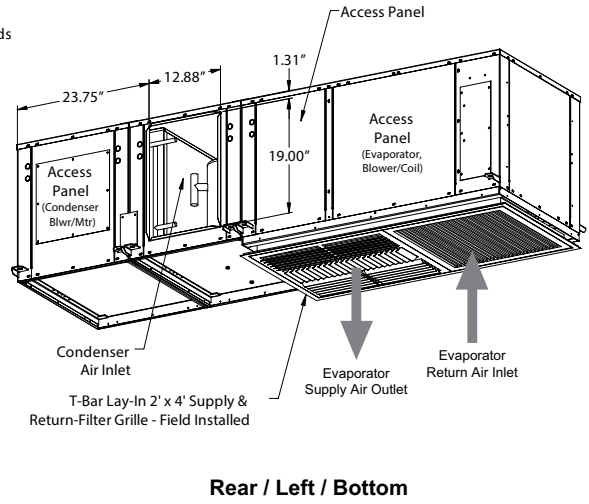
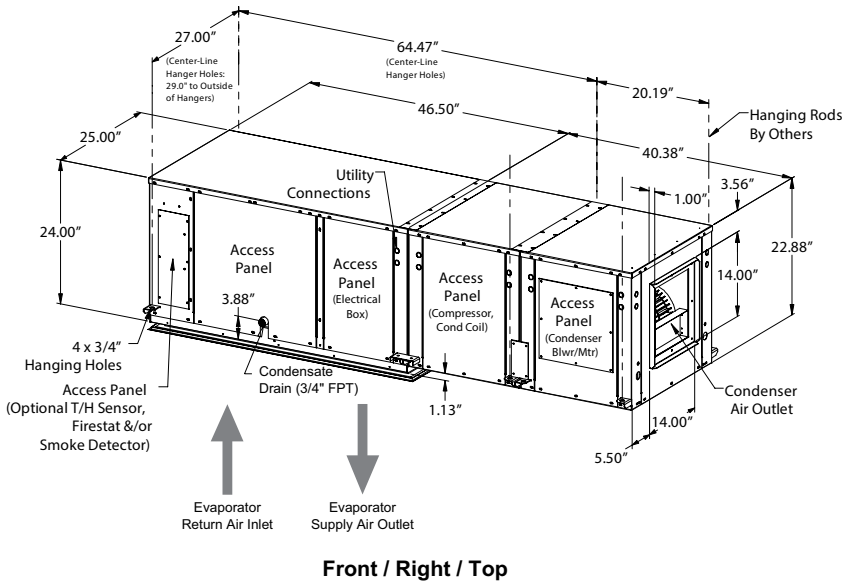

11kW (3T), Air Cooled, Self-Contained (Ducted Evap)

Models: SCA-036

2-Side Access:
18"-24" on Front & Rear Sides!

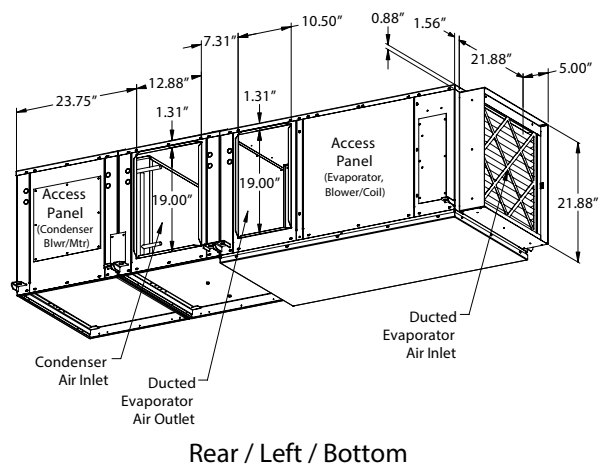
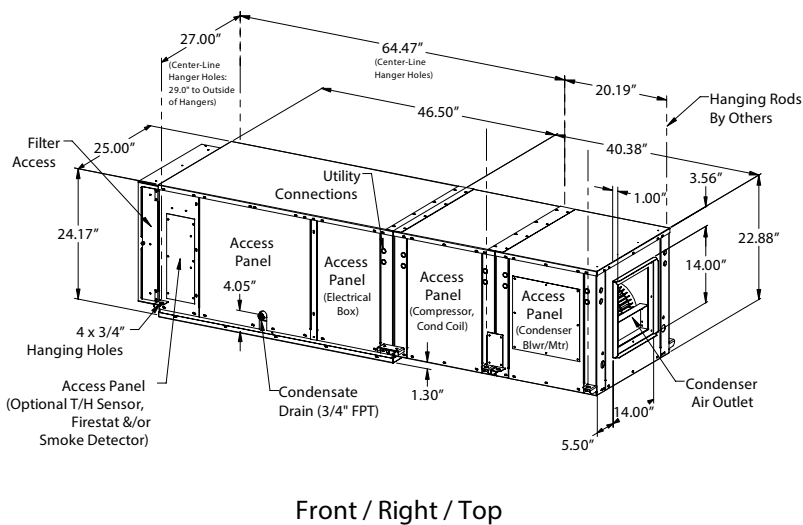

4-7kW (1-2T), Water/Glycol Self-Contained & Split DX Evap (Spot Cooler)

Models: SCW, SCG & SCE-012, 018 & 024

2-Side Access:
18"-24" on Front & Rear Sides!

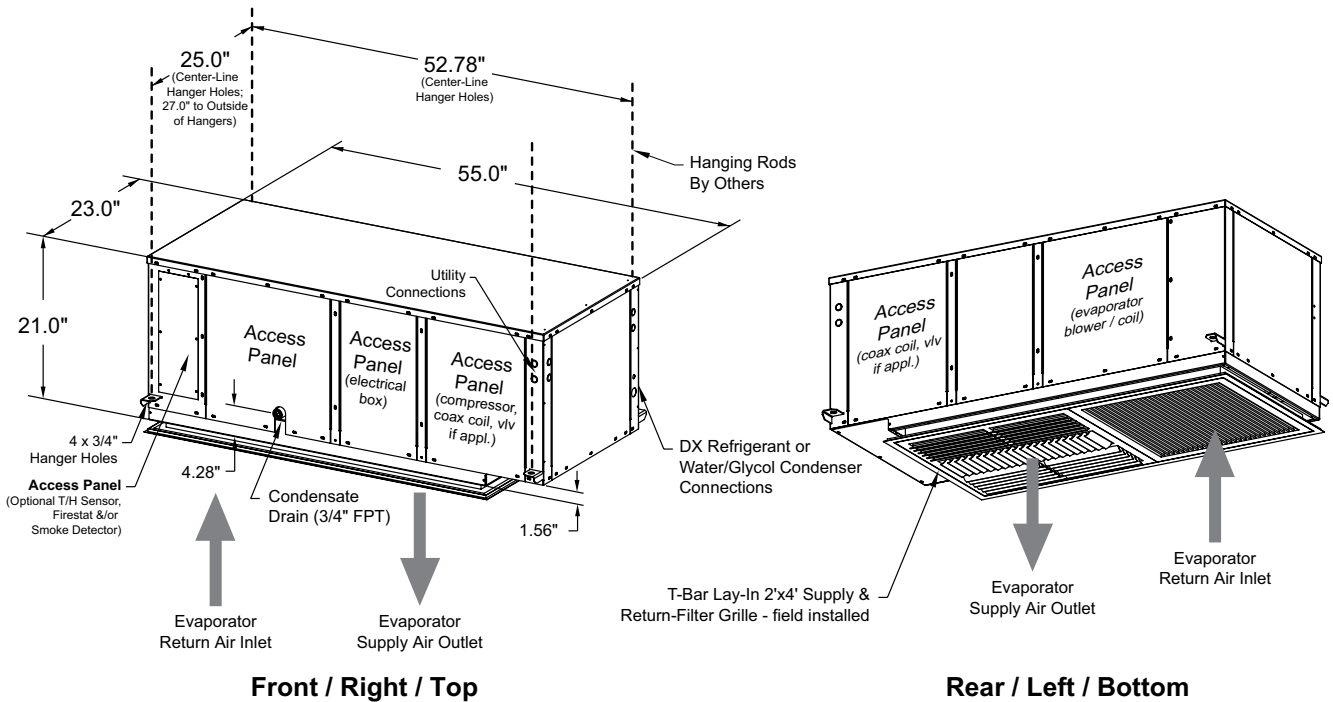

4-7kW (1-2T), Water/Glycol Self-Contained & Split DX Evap (Ducted Evap)

Models: SCW, SCG & SCE-012, 018 & 024

2-Side Access:
18"-24" on Front & Rear Sides!

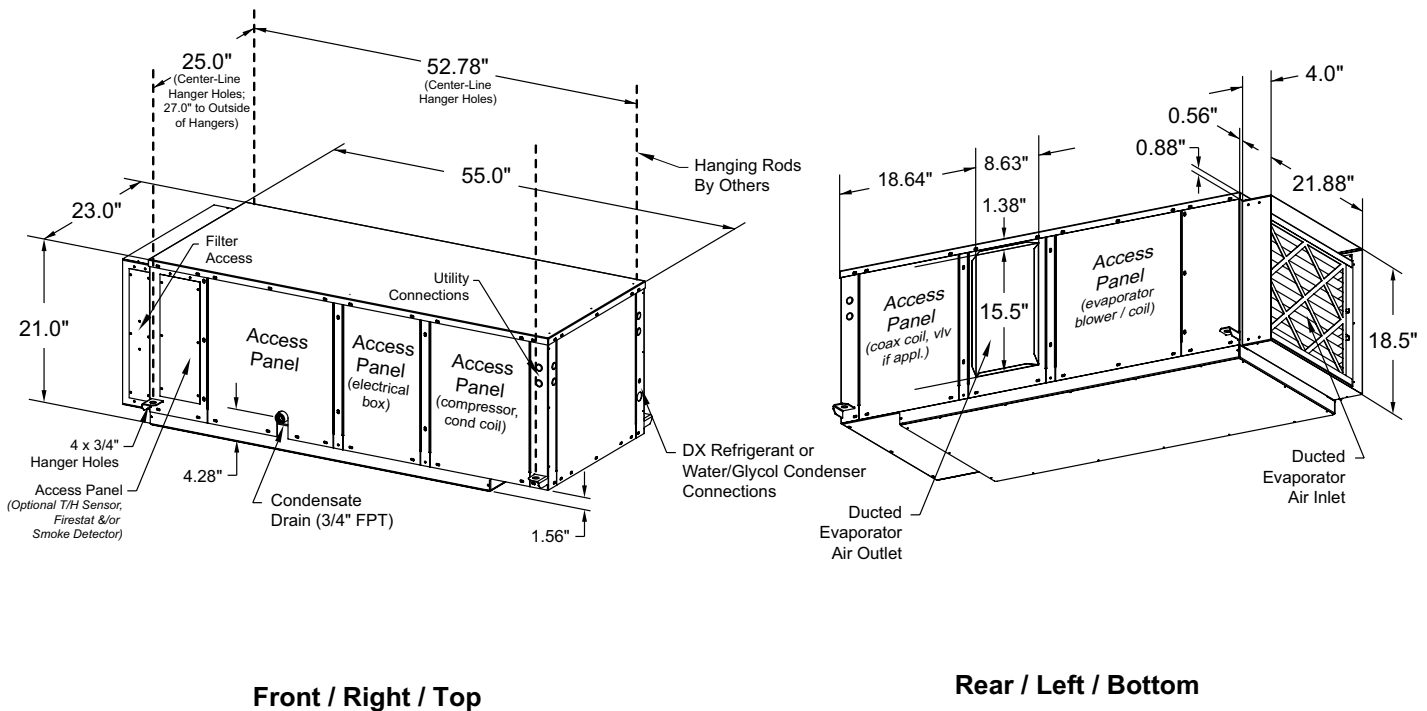

9kW (2.5T), Water/Glycol Self-Contained & Split DX Evap (Spot Cooler)
 Models: SCW, SCG & SCE-030

2-Side Access:
 18"-24" on Front & Rear Sides!

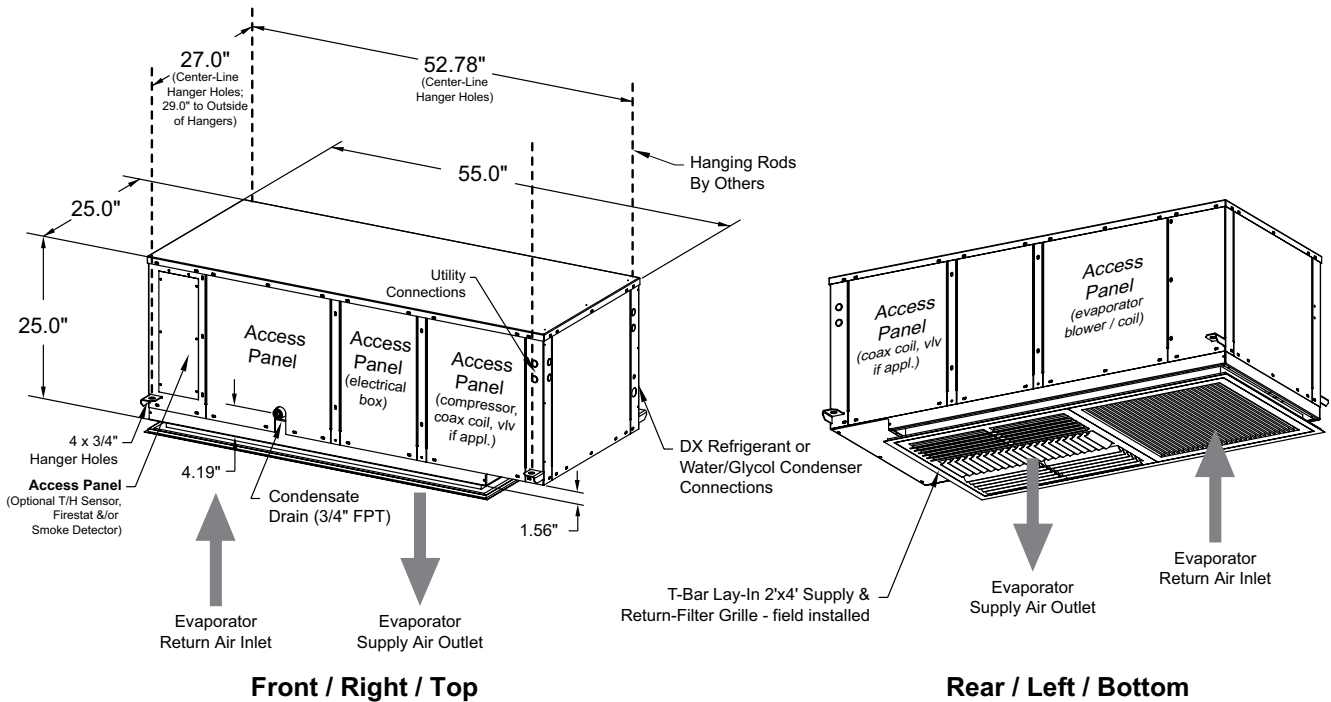

9kW (2.5T), Water/Glycol Self-Contained & Split DX Evap (Ducted Evap)
 Models: SCW, SCG & SCE-030

2-Side Access:
 18"-24" on Front & Rear Sides!

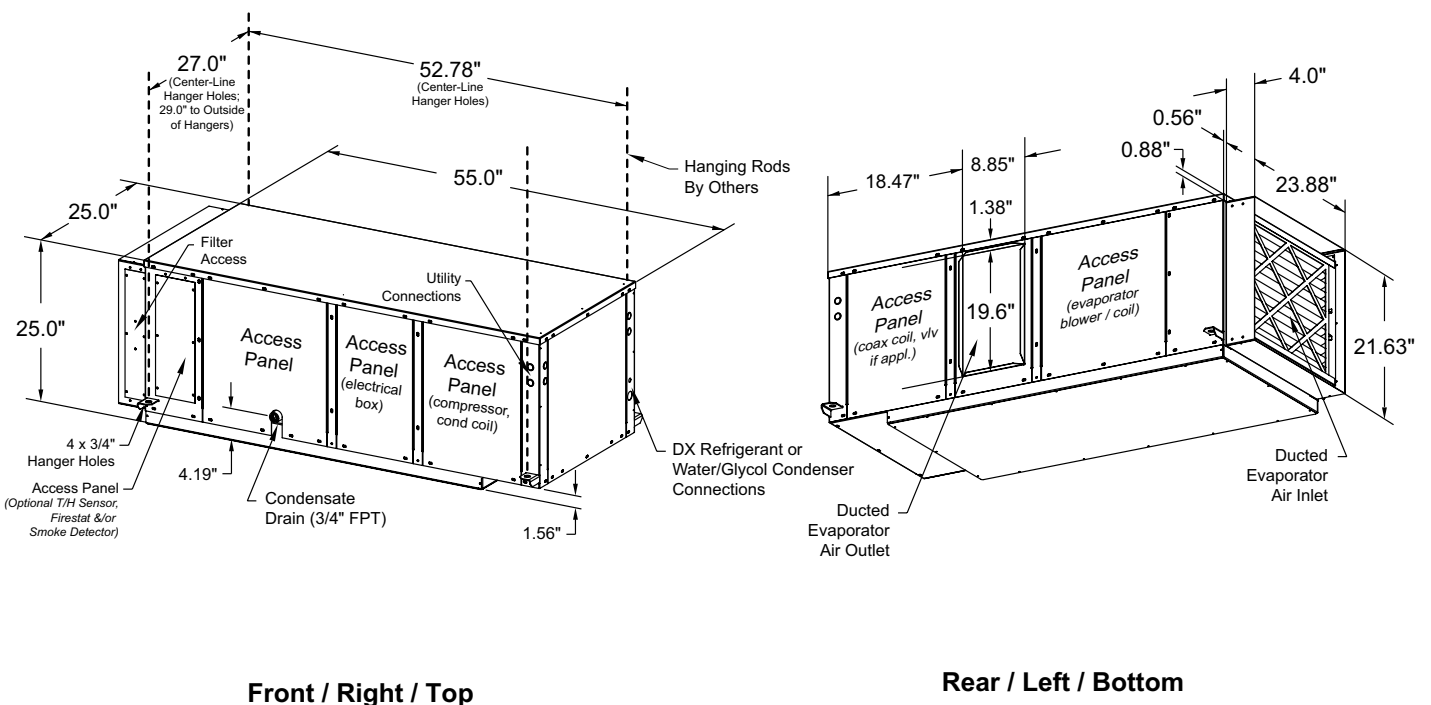

11kW (3T), Water/Glycol Self-Contained & Split DX Evap (Spot Cooler)

Models: SCW, SCG & SCE-036

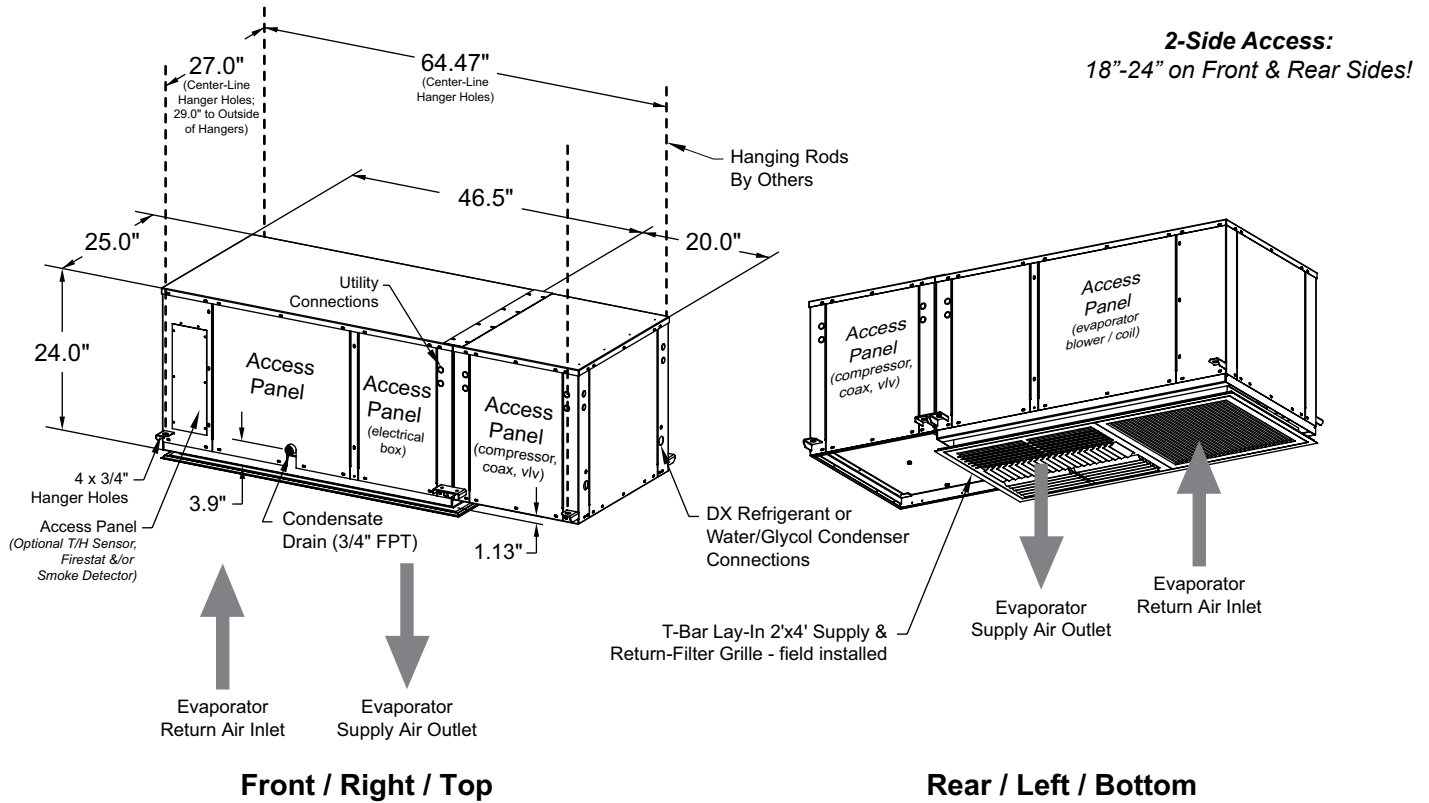

11kW (3T), Water/Glycol Self-Contained & Split DX Evap (Ducted Evap)

Models: SCW, SCG & SCE-036

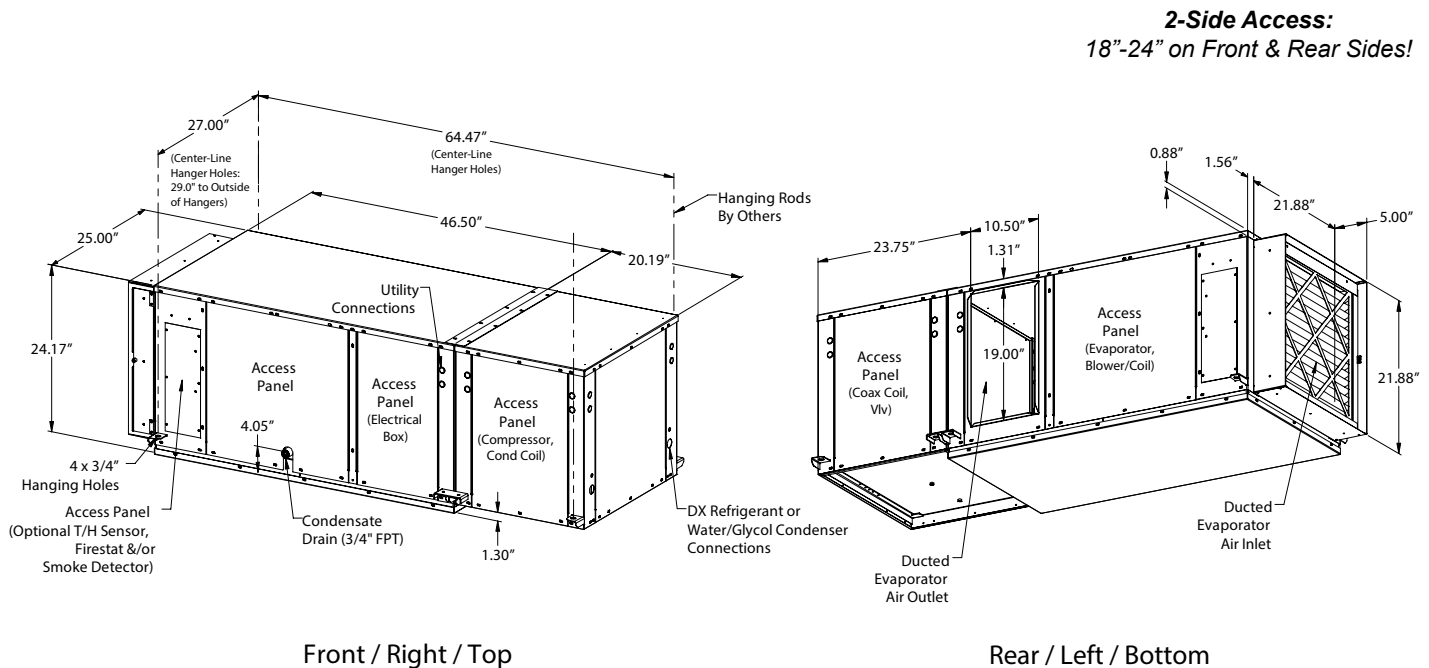

4-7kW (1-2T), DX Split and Chilled Water, Air Handling Units (Spot Cooler)

Models: SCH & SCC-012, 018 & 024

2-Side Access:
18"-24" on Front & Rear Sides!

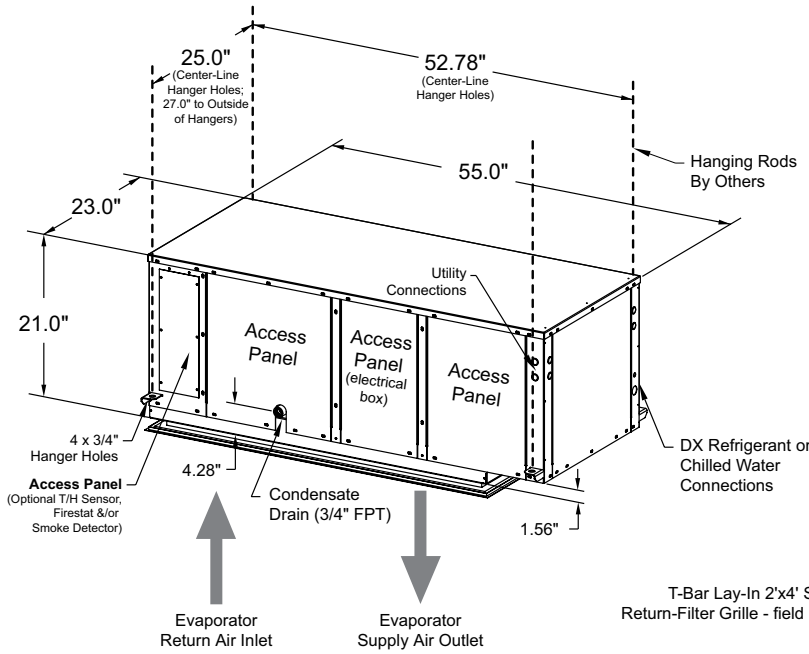

Front / Right / Top

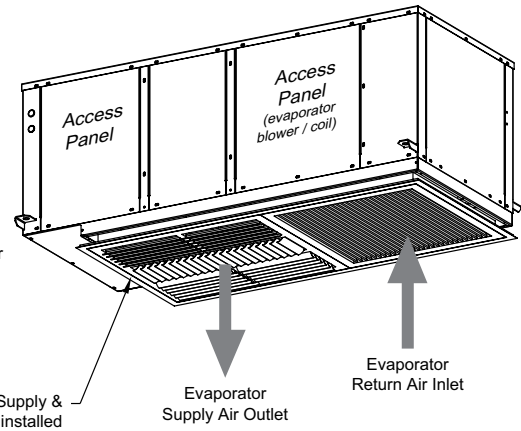

Rear / Left / Bottom

4-7kW (1-2T), DX Split and Chilled Water, Air Handling Units (Ducted Evap)

Models: SCH & SCC-012, 018 & 024

2-Side Access:
18"-24" on Front & Rear Sides!

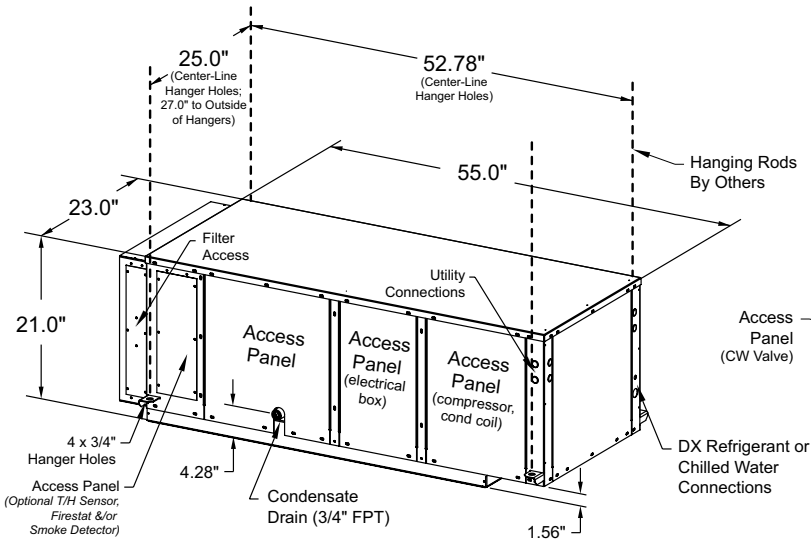

Front / Right / Top

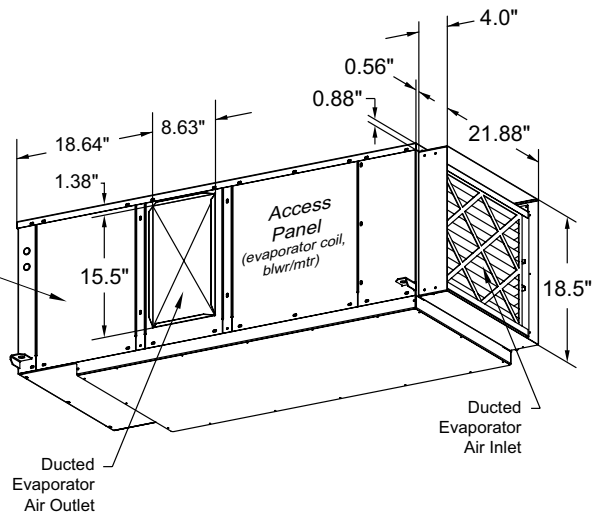

Rear / Left / Bottom

9kW (2.5T), DX Split and Chilled Water, Air Handling Units (Spot Cooler)

Models: SCH & SCC-030

2-Side Access:
18"-24" on Front & Rear Sides!

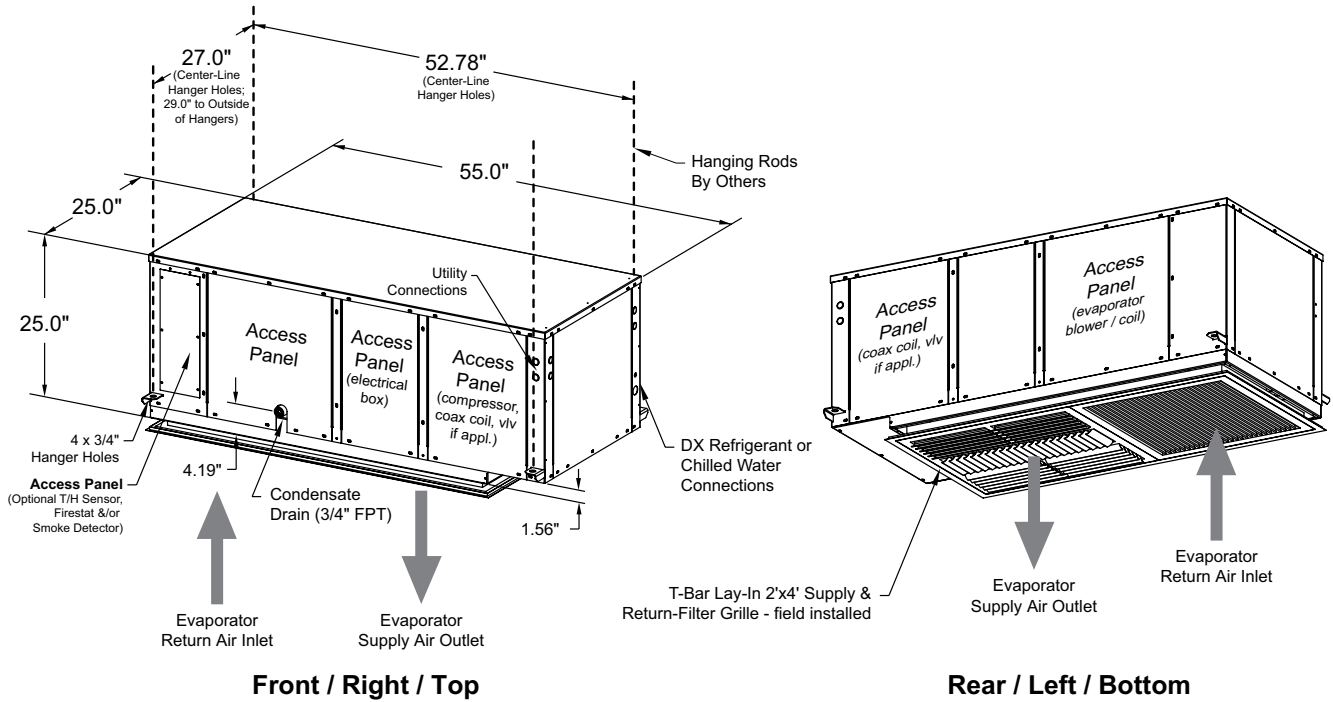

9kW (2.5T), DX Split and Chilled Water, Air Handling Units (Ducted Evap)

Models: SCH & SCC-030

2-Side Access:
18"-24" on Front & Rear Sides!

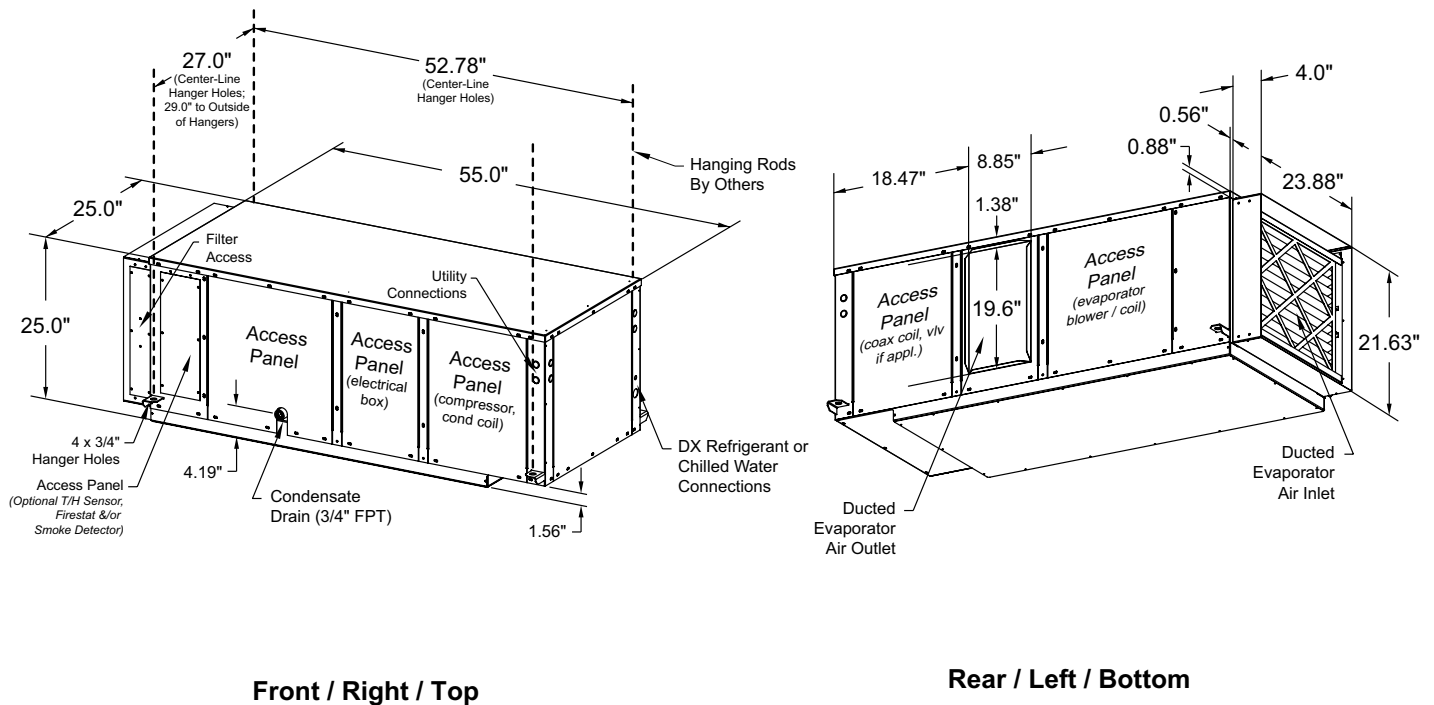

11kW (3T), DX Split and Chilled Water, Air Handling Units (Spot Cooler)

Models: SCH & SCC-036

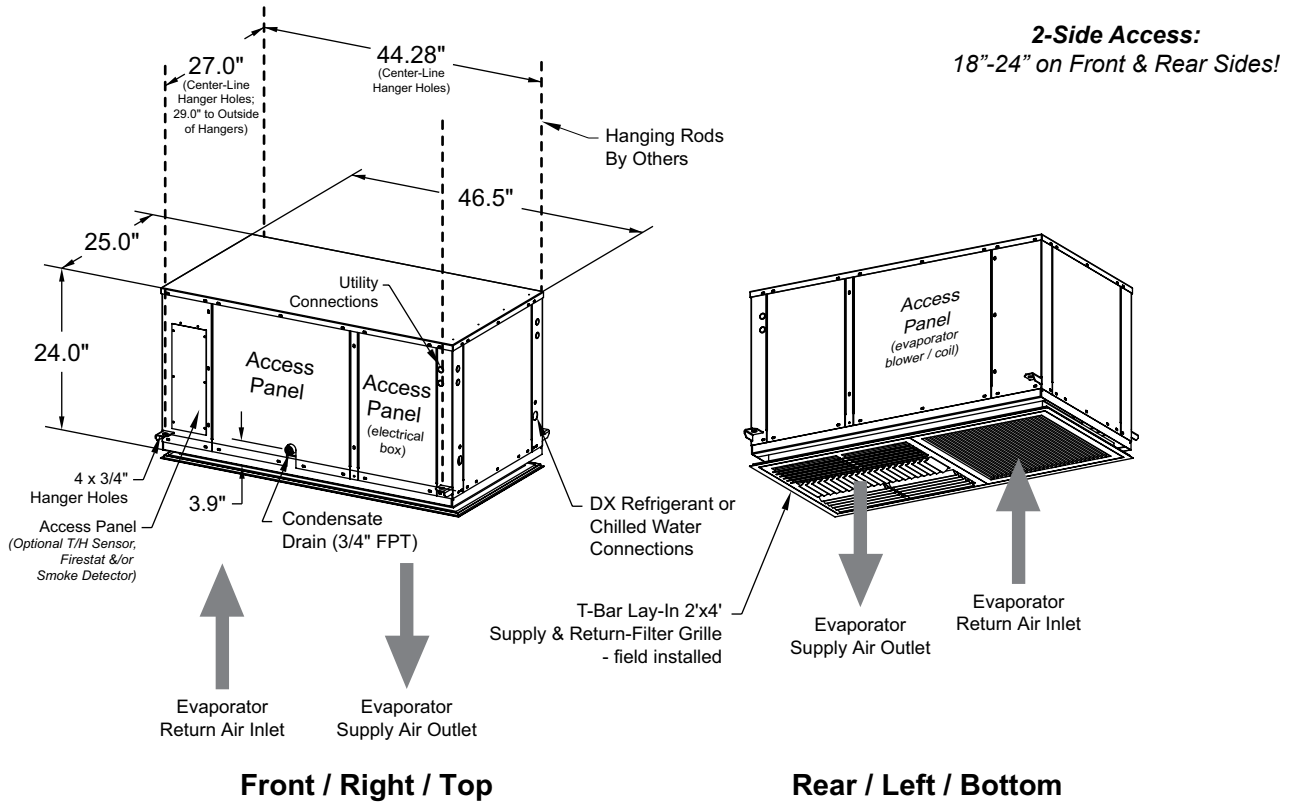

11kW (3T), DX Split and Chilled Water, Air Handling Units (Ducted Evap)

Models: SCH & SCC-036

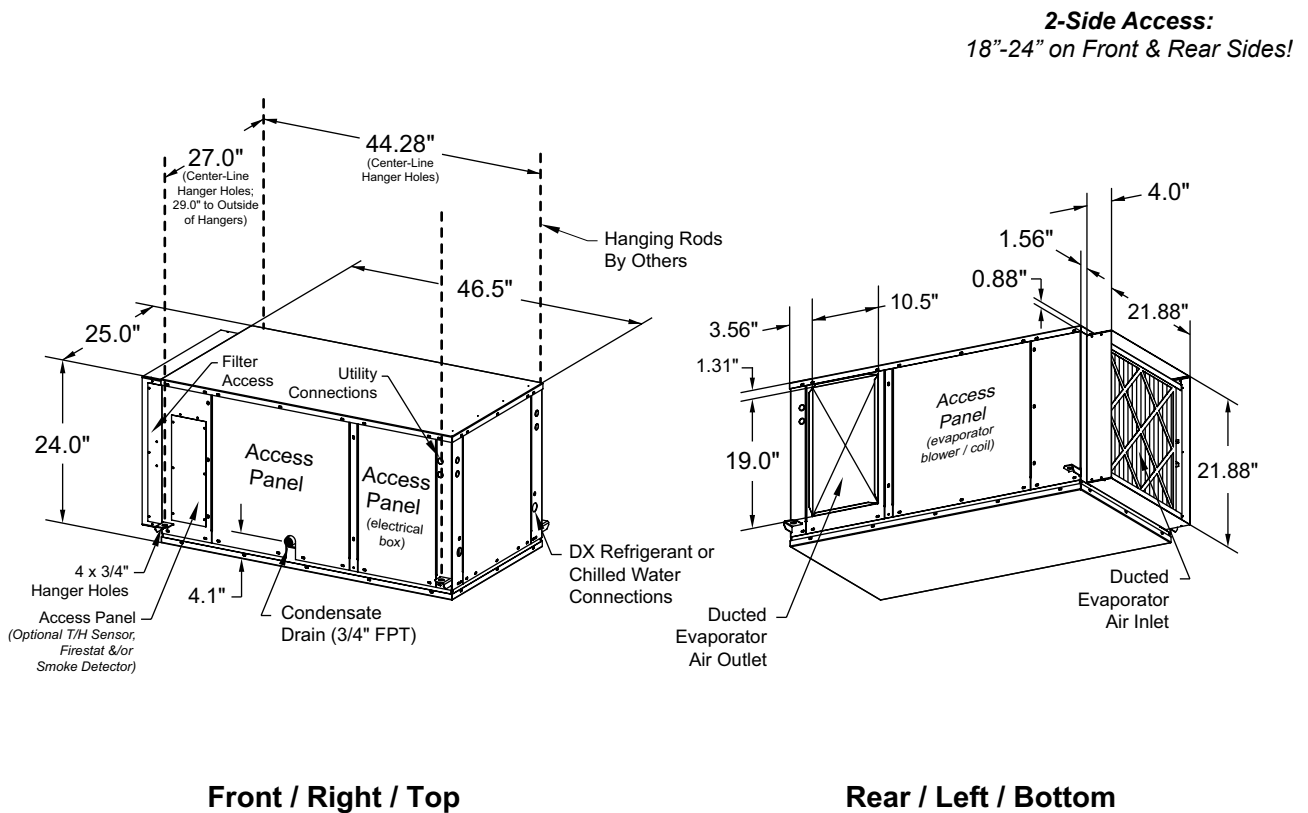

4-11kW (1-3T), Outdoor, DX - Air Cooled Propeller Fan, Remote Condensing Units & Condensers Models: XPU & XP1-012 thru 036

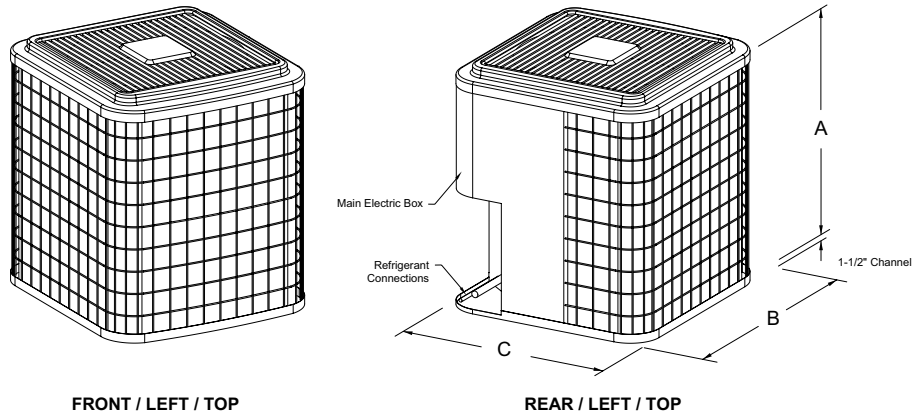

XP1 & XPU-() Model No.	Unit Size (Nominal)	DIMENSIONS (inches)		
		A	B	C
XP1/XPU-012	4kW (1T)	24-13/16	23-1/8	23-1/8
XP1/XPU-018	5kW (1.5T)	25	25-3/4	25-3/4
XP1/XPU-024	7kW (2T)	28-11/16	23-1/8	23-1/8
XP1/XPU-030	9kW (2.5T)	31-3/16	25-3/4	25-3/4
XP1/XPU-036	11kW (3T)	32-5/16	31-3/16	31-3/16

4-11kW (1-3T), Indoor, Remote Centrifugal Blower DX Air Cooled Condensing Units & Condensers “Same-Face (standard) or Optional Straight-Thru & “90° L” Air Patterns” Models: CCU & CCX-012 thru 036

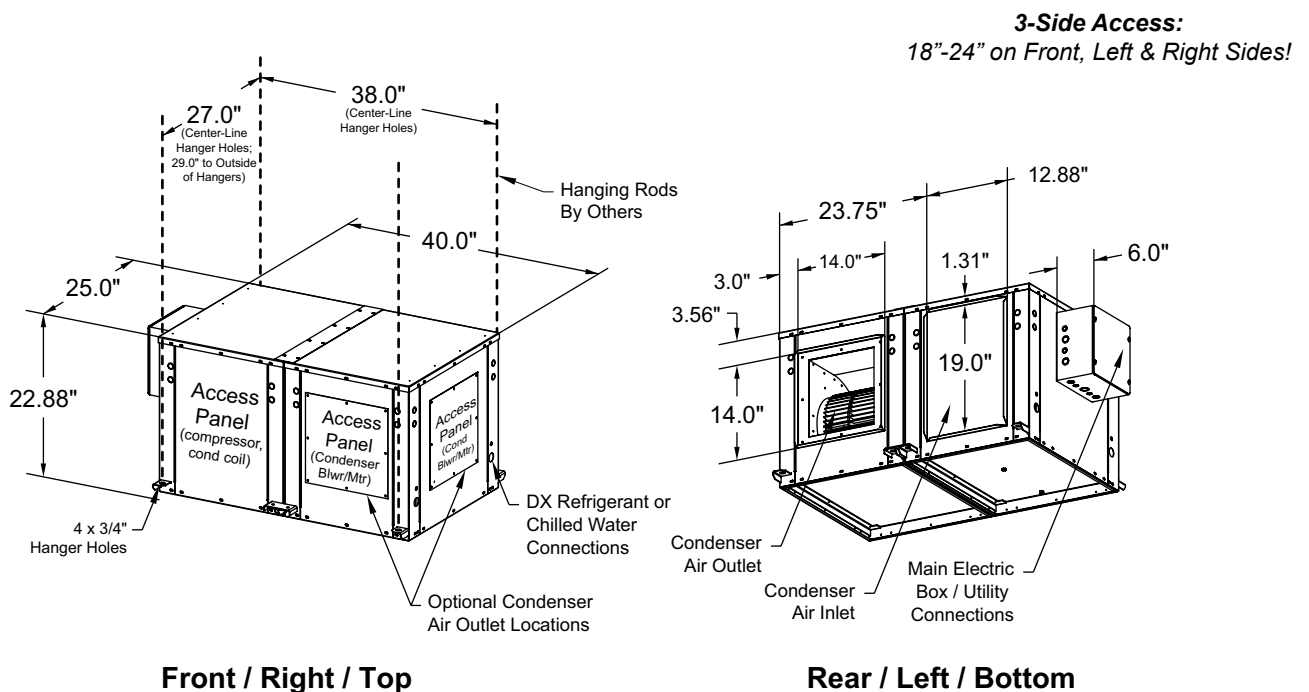

4-11kW (1-3T), Indoor, Remote DX Water/Glycol Cooled Condensing Units

Models: CWU & CGU-012 thru 036

3-Side Access:
18"-24" on Front, Left & Right Sides!

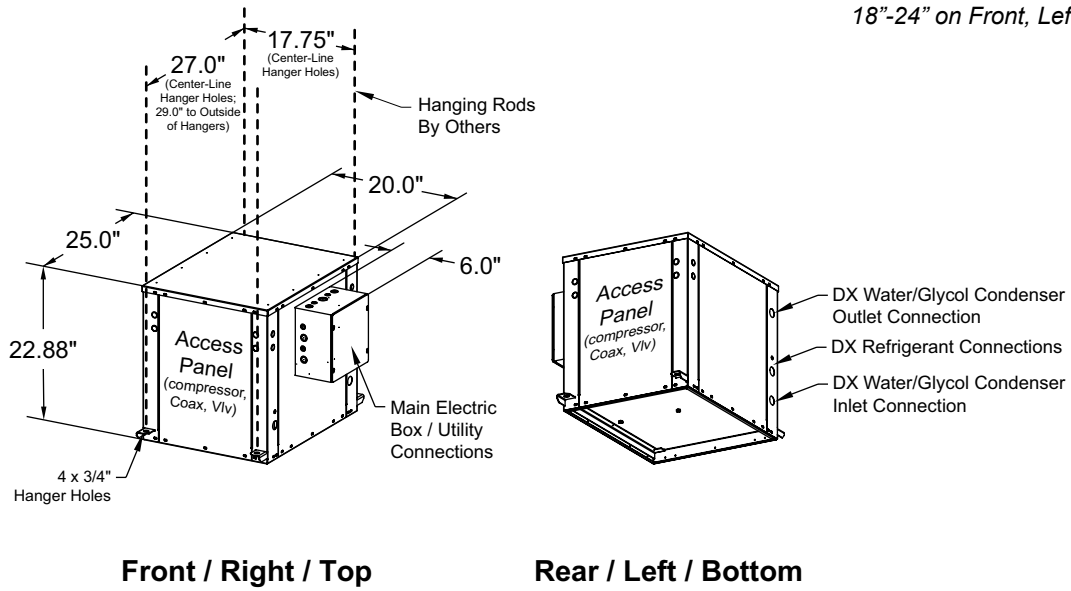

Front / Right / Top

Rear / Left / Bottom

Innovative HVAC Solutions

MissionCritical Units - Precision A/C's



**SC-2x4 SpotCool
Ceiling Mounted A/C's**
(4-11kW, 1-3 Tons)



**HK Horizontal Ducted
Ceiling Mounted A/C's**
(4-70kW, 1-20 Tons)



**MC Vertical Floor Mtd A/C's
Up-Flow & Down-Flow**
(4-352kW, 1-100 Tons)



**WC Wall-Cassette and
FC Floor-Console Mtd A/C's**
(4-18kW, 1-5 Tons)

Outdoor-Air Units - IAQ High Percent (20%-100% OA)



HK-OA Horizontal Ceiling Mtd
(1-30 Tons)



VK-OA Vertical Floor Mtd
(1-50 Tons)

Specialty Units - A/C's & Water Source Heat Pumps



**SC-2x4 SpotCool
Ceiling Mtd A/C's**
(4-11kW, 1-3 Tons)



**HK Horizontal Packaged
& Split Ceiling Mtd A/C's**
(4-70kW, 1-20 Tons)



**VK Vertical Packaged &
Split Floor Mtd A/C's**
(4-105kW, 1-30 Tons)

Remote Heat Rejection Units



**Remote Air Cooled
Condensers, Condensing Units &
Glycol Drycoolers**

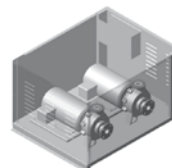

**Single, Dual & Triplex
Glycol Pump Packages**
(1/2 to 50 HP, VFD Optional)