

Engineering Manual

MC2™ DX

Mission Critical

Vertical Floor Mounted A/C's
(Dual DX Scroll Compressors)



Features & Benefits

- > 21-105kW (6-30 Tons) Capacities
- > Precision Applications
 - Data Center/Colocation/Hosting for Banks, Financial, Healthcare, Government, Retail and Wholesale Institutions!
- > Vertical Floor Mounted Upflow & Downflow Configurations
- > DX Air, Water & Glycol Cooled Plus Free-Cooling Economizers
- > 24/7/365 Low Ambient Operation!
- > Total Temp & Humidity Control
 - Free-Energy Hot Gas Reheat or Electric Reheat/Heat
 - Steam Humidifier
- > Microprocessor Controls & More

**From
21-105kW**

**Data Center/
Colocation/Hosting**

AboveAir™ MissionCritical™ vertical floor mounted precision air conditioners are the reliable environmental control solution to your precision cooling needs. Available in a wide variety of cooling methods and cabinet configurations including a full range of options, **AboveAir™** air conditioners are a step above!

- ☑ 100% Front-Access cabinet design
- ☑ Total Temperature & Humidity Control
- ☑ Up-Flow & Down-Flow air patterns
- ☑ Variety of cooling methods
- ☑ Self-contained & split systems
- ☑ Flexible options and accessories
- ☑ R410a Refrigerant
- ☑ Energy efficient operation

DX - Air Cooled, MCE & XPX-()

DX - Air Cooled Split with Propeller Fan, Outdoor Remote Condenser

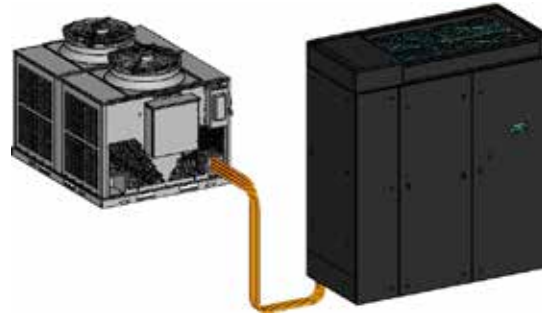

DX - Water Cooled, MCW-()

DX - Water Cooled Self-Contained (Optional Free-Cooling Economizers!)

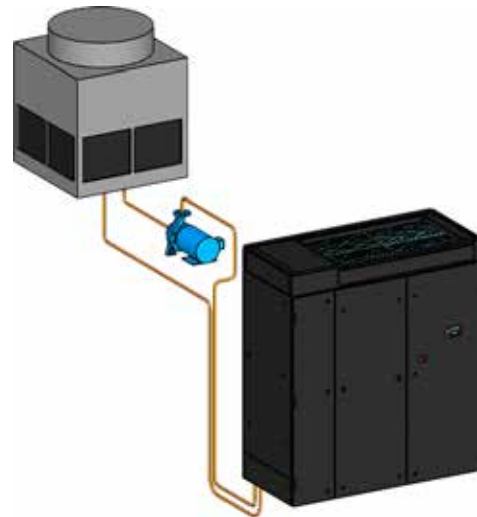

DX - Glycol Cooled, MCG-()

DX - Glycol Cooled Self-Contained Plus Glycol Drycoolers & Pump Packages (Optional Free-Cooling Economizers!)

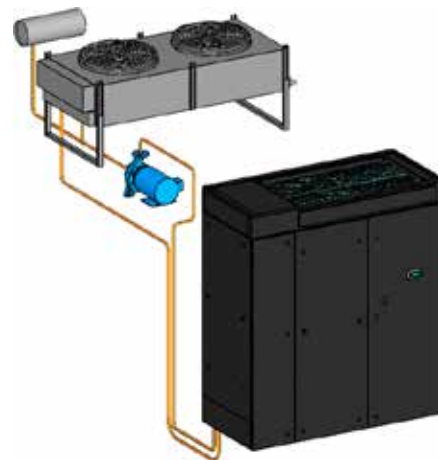

Contents

Introduction	2
Model Configurations	2
Features and Benefits	3
Model Nomenclature	4
Guide Specifications	5-9
DX - Cooling Capacity Data	10-12
Dual-Cool - Cooling Capacity Data	13
Free-Cooling - Cooling Capacity Data	14-15
Physical Data	16-17
Heat Rejection Data	18-19
Electrical Data	20-23
Typical Wiring Schematics	24-25
Recommended Service Clearance	26
Dimensional Data	27-31
Other AboveAir Products	Back Cover!

AboveAir™ MissionCritical™ precision A/C's are designed to meet your unique application dependent requirements. Select from a wide range of options and configurations:



Up-Flow Air Pattern

**21-105kW
(6-30T)
Dual Circuit DX**



Down-Flow Air Pattern

Variety of Standard & Optional Features



Standard & Optional Features:

- MC-2000, Advanced Microprocessor Controls
- Electrode Steam Canister Humidifier
- Electric Reheat/Heat or Hot Gas Reheat
- Dual Scroll Compressors (Fixed, 2-Spd or Digital)
- EC Backward-Inclined Plug Fans
- Free-Cooling Economizer Coils
- High Efficiency Air Filtration (4" Merv-8, 11 or 13)
- Low Ambient Head Pressure Control
- 2 & 3-Way 350 psig Water / Glycol Cooled Head Pressure Control Regulating Valves
- Hot Gas Bypass
- Low Entering Condenser Water/Glycol Kit
- Top or Bottom Piping Connections

Accessories:

- 2 or 3-Way Plenum Discharge Boxes
- Floor Stands & Turning Vanes
- Condensate Pumps - Factory Installed
- Main Power Electrical Disconnects
- Firestats & Smoke Detectors
- Remote Water-Leak Detectors
- Condenser Water/Glycol Flow Switches
- Compressor Sound Jackets
- Glycol Pump Packages & Drycoolers
- ... and more!



Model Nomenclature

Packaged Systems & Split Evaporators

Split, DX - Remote Condensers & Condensing Units

MC	E - 070	D - 4 - 00	ER	H - EC - 00	- UF2	- C2 - D3
a	b - c	d - e - f	g	h - i - j	- k	- l - m

XPX	- 070	D - 4 - EC	- VF	1 - 00	- B
a	- b	c - d - e - f	g	- h	- i

- a: MC** - MissionCritical MC2 Vertical Floor A/C
- b: E** - DX, Split Evaporator (Compressor with Evaporator)
G - DX, Glycol Cooled - Packaged Self-Contained
W - DX, Water Cooled - Packaged Self-Contained
- c: 021** = 21kW (6.0T); **028** = 28kW (8.0T); **035** = 35kW (10.0T);
042 = 42kW (12.0T); **053** = 53kW (15.0T); **063** = 63kW (18.0T);
070 = 70kW (20.0T); **088** = 88kW (25.0T); **097** = 97kW (27.5T);
105 = 105kW (30.0T)
- d: D** - Dual Circuit DX System
- e: 1** - 208-230V / 1 Ph / 60 Hz
3 - 208-230V / 3 Ph / 60 Hz
4 - 460-480V / 3 Ph / 60 Hz
5 - 575V / 3 Ph / 60 Hz
7 - 277V / 1 Ph / 60 Hz
8 - 460-480V / 1 Ph / 60 Hz
- f: 00** - No Hot Gas Reheat
HG - Hot Gas Reheat (2-POS, On/Off)
MG - Hot Gas Reheat (Modulating 0-10Vdc)
HR - Hot Water Reheat/Heating Coil
SR - Steam Reheat/Heating Coil
- g: 00** - No Unit Mtd Electric Heat
EO - Electric Heat Only, No Reheat
ER - Electric Reheat/Heat
- h: 0** - No Humidifier
H - Electrode Canister Steam Humidifier
- i: EC** - EC = EC Plug Fan (Direct-Drive, Backward-Inclined Centrifugal Impeller, 0-10Vdc)
- j: 00** - No Economizer
DC - Dual-Cool / Alternate Water Source Coil
FE - Water/Glycol Side Free-Cooling Economizer Coil
- k: DFB** - Down-Flow Evap Air Pattern w/ Free or Ducted Top Return & Bottom Discharge to Raised Floor
DFE - Down-Flow Evap Air Pattern w/ Free or Ducted Top Return & Front Free-Discharge to Floor Level
UF0 - Up-Flow Evap Air Pattern w/ Front Free-Return & Top Ducted Discharge
UF1 - Up-Flow Evap Air Pattern w/ Front Free-Return & Top 1-Way Plenum Discharge Box
UF2 - Up-Flow Evap Air Pattern w/ Front Free-Return & Top 2-Way Plenum Discharge Box
UF3 - Up-Flow Evap Air Pattern w/ Front Free-Return & Top 3-Way Plenum Discharge Box
UFR - Up-Flow Evap Air Pattern w/ Rear Ducted or Free-Return & Top Ducted Discharge
- l: C2** - MC2 Cabinet Size ... A2 = 21-35kW (6-10T); B2 = 42-53kW (12-15T); C2 = 63-70kW (18-20T); D2 = 88kW (25T); E2 = 97-105kW (27.5-30T)
- m: D1** - Dual Scroll Compressors - 1st Circuit Fixed Spd w/ Hot Gas Bypass; 2nd Circuit Fixed Spd
D3 - Dual Scroll Compressors - 1st Circuit Digital; 2nd Circuit Fixed Spd
D6 - Dual Scroll Compressors - 1st Circuit 2-Spd; 2nd Circuit Fixed Speed

- a: VCX** - DX, Split Indoor Vertical Floor Mtd Remote Air Cooled Centrifugal Blower Condenser (Compr Located w/ MCE Evap)
XCX - DX, Split Indoor Ceiling Mtd Remote Air Cooled Centrifugal Blower Condenser (Compr Located w/ MCE Evap)
XPX - DX, Split Outdoor Mtd Remote Air Cooled Propeller Fan Condenser, (Compr Located w/ MCE Evap)
- c: 021** = 21kW (6.0T); **028** = 28kW (8.0T); **035** = 35kW (10.0T);
042 = 42kW (12.0T); **053** = 53kW (15.0T); **063** = 63kW (18.0T);
070 = 70kW (20.0T); **088** = 88kW (25.0T); **097** = 97kW (27.5T);
105 = 105kW (30.0T)
- d: D** - Dual Circuit DX System
- d: 1** - 208-230V / 1 Ph / 60 Hz
3 - 208-230V / 3 Ph / 60 Hz
4 - 460-480V / 3 Ph / 60 Hz
5 - 575V / 3 Ph / 60 Hz
7 - 277V / 1 Ph / 60 Hz
8 - 460-480V / 1 Ph / 60 Hz
- e: 00** - N/A
AA - Axial Fan w/ Std Motor
AB - DWDI FC BD Blower w/ ODP Motor
EA - Axial Fan w/ ECM
EC - EC DD Backward-Inclined Impeller
- f: 00** - Not Applicable
LD - Ducted, 90 Degree / Right-Angle, In-Front / Out Left-Side
MI - Ducted, Mirror-Image Same-Face Condenser Air Pattern
RD - Ducted, 90 Degree / Right-Angle, In-Rear / Out Right-Side
SF - Ducted, Same Face Condenser Air Pattern
ST - Ducted, Straight-Thru (ZST) Condenser Air Pattern
VF - Free Airflow, Vertical Discharge Air Pattern
- g: 0** - Not Applicable
1 - Slab or Wrap Around Type
- - Cabinet Size ... VCX-B, C, D, E or F & XCX-B, C or D
- h: 00** - No Compressor in this section (DX Condenser Model)
- i: 0** - No Head Pressure Control
A - Low Amb Fan Cycling Head Pressure Control
B - Low Amb Variable Speed Fan Head Pressure Control
C - Low Amb Flooded Head Pressure Control
D - Water/Glycol Regulating Valve - 2-Way, 150 psig
E - Water/Glycol Regulating Valve - 2-Way, 350 psig
F - Water/Glycol Regulating Valve - 3-Way, 150 psig
G - Water/Glycol Regulating Valve - 3-Way, 350 psig

General

Summary



These specifications describe the requirements for a vertical floor mounted packaged (or split) precision air conditioner. The system shall be designed to control space temperature and humidity.

The air conditioning manufacturer shall design and furnish all equipment in the quantities and configurations shown on the project plans and specifications.

The system shall be provided by AboveAir Technologies in Frederick, Maryland, USA. The system shall be listed by Intertek (ETL Semko), Inc. to conform with UL Std 1995 and be certified to CAN/CSA Std C22.2 No. 236 (Control No. 3091370). The system shall be NYC MEA229-06-E and Chicago Code Approved. The system model number shall be _____.

Design Requirements

The system shall be an AboveAir Technologies MissionCritical™ brand, factory assembled and tested. The system shall be designed for indoor installation.

The system shall have a total cooling capacity of _____ BTU/H, and a sensible cooling capacity of _____ BTU/H, based on an entering air condition of _____ °F DB, and _____ °F WB, _____ % RH.

The evaporator section shall be designed for _____ Volt, _____ Phase, _____ Hertz main power supply. The remote condensing unit section (if applicable) shall be designed for _____ Volt, _____ Phase, _____ Hertz main power supply.

Submittals

Submittals shall be provided after manufacturer's receipt of a written purchase order and shall include: Detailed Performance and Electrical Data; Guide Specifications; and Dimensional Drawings.

Quality Assurance

The system shall be factory run tested prior to shipment. Testing shall include, but shall not be limited to: "HiPot" Test (2 times rated voltage plus 1000 volts, per UL 1995 testing requirements). The system shall be designed and manufactured according to world class quality standards.

Products

Standard Features

Cabinet

The cabinet chassis and access panels shall be powder-coat painted heavy gauge galvanized steel for decor matching and corrosion resistance. Cabinet access panels shall rest in recessed pockets designed for minimum air leakage. The cabinet and access panels shall be lined with 2 lb/ft² high density sound and thermal insulation and sealed with self-extinguishing gasketing conforming to NFPA 90A and 90B.

Component Access

The unit shall be serviceable through front and side (as required) access panels with quick-release quarter-turn fasteners.

Electrical System

General:

The electrical system shall conform to National Electric Code (NEC) requirements according to UL 1995. The control circuit shall be a 24 VAC low voltage circuit.

The electrical system shall include, but not be limited to the following factory installed items: main power distribution block; grounding lug; 24 VAC control transformer; terminal connections; and motor controllers with start protection and circuit breakers for blower motors, compressors and each electric heater stage (if applicable).

Packaged Systems: (single point power) Self-Contained systems shall be designed for single point main power connection.

Split DX Systems: (separate power) Split systems shall require separate main power supplies to the evaporator and condensing unit sections. The evaporator and condensing unit sections shall be electrically interlocked by a field wired 24 volt control signal.

Overflow Safety Float Switch:

The system shall be provided with a factory installed float type condensate overflow safety switch. The circuit shall be designed to shut down all system water producing operations in the event of an overflow condition.

Main Power, Disconnect

(MC_Evap Section)



The indoor evaporator section shall be provided with a factory installed main power non-fused disconnect. The disconnect shall be NEMA rated for indoor or outdoor installation as required.

Air Distribution

Evap Blower/Motor

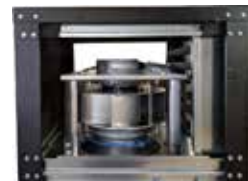

The evaporator blower assembly shall be a backward-inclined direct-drive centrifugal impeller with variable speed EC (electronically commutated) motor. The blower shall be designed for _____ CFM @ _____ inches external static pressure (e.s.p.)

Variety of Air Patterns



Up-Flow (UF) Down-Flow (DF)

Up-Flow Air Pattern:

UF*: Front-Free Return

The system shall be configured for up-flow evaporator air pattern with front-free return and top discharge. (Refer to Plenum Discharge Box Options.)

UR*: Rear-Ducted Return

The system shall be configured for up-flow evaporator air pattern with rear ducted return and top discharge.

Down-Flow Air Pattern:

DFFB: Bottom Disch Into Raised Floor

The system shall be configured for down-flow evaporator air pattern with top free or ducted return and bottom discharge into raised floor. (Refer to Floor Stand Options.)

DFF: Front Discharge Floor Level

The system shall be configured for down-flow evaporator air pattern with top free or ducted return and front free discharge to floor level.

Air Filtration



The return air filters shall be 4 inch thick pleated and Merv-8 efficiency rated (based on ASHRAE 52.2). The filters shall be serviceable without shutting down the system.

Piping Connection Location

- Top Piping Connections
- Lower-Side Piping Connections
- Bottom Piping Connections

Direct Expansion Systems

DX - Evaporator Coil



The DX evaporator coil shall be constructed of copper tubes and aluminum fins. The system shall be designed for a draw-through air pattern for maximum heat transfer. Coil end-plates shall be hot dipped galvanized. The evaporator coil shall be mounted in an insulated stainless steel condensate drain pan.

Dual Scroll Compressors



Each compressor shall be the high efficiency, low sound Scroll type mounted

on vibration isolators and located in a separate compartment out of the evaporator air stream to facilitate servicing while equipment is operating. Each compressor shall be complete with reversible positive oil pump, charging and service ports, internal spring isolation, and discharge gas vibration eliminator.

(Note: 2-Speed & Modulating Digital Scroll Compressors are optionally available!)

DX - Refrigeration Circuit



Each refrigeration circuit shall be pre-piped with type "L" refrigerant copper tubing. The refrigeration system shall include but not be limited to: expansion valve with external equalizer and rapid bleed-through capacity. Features shall include filter dryer, sight glass, pressure fittings and high pressure/low pressure safety cutouts.

Cooling Configurations

DX - Air Cooled Split

(Split Evap & Outdoor Remote Condenser) MCE-() & XPX-()



The system shall be a split configuration with compact indoor vertical floor mounted dx evaporator precision air conditioner with outdoor dx air cooled propeller fan remote condenser. The compressor shall be located in the indoor evaporator section. The condenser shall be sized for full heat of rejection at 95°F ambient and be capable of operation to ___ °F low ambient air temperature.

The system shall be refrigerant charged and run tested at the factory prior to shipment. The evaporator and condenser sections shall ship separately with a dry-nitrogen charge ready for field refrigerant charging.

DX - Water Cooled

(Self-Contained Systems) MCW-()

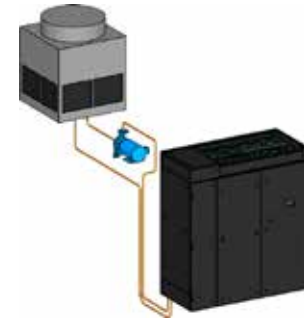

The system shall be a self-contained, compact indoor vertical floor mounted dx water cooled precision air conditioner. The system shall include a water cooled tube-in-tube coaxial condenser and factory installed head pressure controlling 2-way water regulating valve rated for 350 psi w.w.p. The water cooled condenser shall be designed to provide the total required system heat of rejection at 85°F entering water temperature and 95°F leaving water temperature. Source water shall be provided by a remote water source (by others).

The system shall require only single point main power supply and ship from the factory with a full operating refrigerant charge.

(Note: 3-Way and High Pressure valves are optionally available)

DX - Glycol Cooled

(Self-Contained Systems) MCG-()



The system shall be a self-contained, compact indoor vertical floor mounted dx glycol cooled precision air conditioner. The system shall include a glycol cooled tube-in-tube coaxial condenser and factory installed head pressure controlling 2-way glycol regulating valve rated for 350 psi w.w.p. The condenser shall be designed to provide the total required system heat of rejection at 110°F entering glycol temperature and 120°F leaving glycol temperature based on 40% ethylene glycol solution. Source glycol shall be provided by a remote glycol drycooler

source (see AboveAir Technologies' FluidCool™ drycoolers).

The system shall require only single point main power supply and shall ship from the factory with a full operating refrigerant charge.

(Note: 3-Way and High Pressure valves are optionally available)

(Note: See AboveAir Technologies' Fluid-Cool™ indoor & outdoor glycol drycooler and PumpAll™ glycol pump packages engineering manuals for more information.)

Free-Cooling w/ DX Water/Glycol Cooled - MCW & MCG-(-)FE

The system shall include a factory installed water/glycol free cooling cycle complete with economizer cooling coil, 2 or 3-way modulating (0-10Vdc) control valve rated for 580 psig, aquastat sensor and automatic control logic. The FE coil shall be capable of providing rated sensible capacity without compressor operation when entering water/glycol fluid temperatures are 45°F or below (adjustable).

(Note: Free-Cool valve must match condenser water/glycol regulating valve 2 or 3-way!)

Dual-Cool, Chilled Water Coil & DX Cooling Cycle - MC_(-)DC

The system shall be a Dual-Cool configuration with primary chilled water coil cooling cycle and back-up DX cooling cycle (DX Air, Water or Glycol Cooled as specified). Based on the available chilled water flow rate and temperature (45°F or below typical, adjustable), the unit's control system shall automatically select either chilled water or DX cooling modes. The system shall be provided with a factory installed 2 or 3-Way Modulating (0-10Vdc) chilled water control valve rated for 580 psig and field installed chilled water supply pipe temperature sensor.

Options

DX Air Cooled Condenser - Low Ambient Control

-20°F Ambient - Variable Spd Fan (XP* & XPU Models)

Variable fan speed head pressure controls (JCI P266 or Modulating EC) shall be factory installed to allow for low ambient operation to -20°F. Compressor cold start time delay relay and crankcase heater shall be factory installed with the -20°F low ambient control feature.

-30°F Flooded Condenser (All Condenser/ing Models)

A flooded condenser system shall be provided to allow for low ambient condenser operation to -30°F. The flooded system shall include a factory installed liquid refrigerant receiver and modulating head pressure control valve. Compressor cold start time delay relay and crankcase heater shall be factory installed with the -30°F low ambient control feature.

DX - Water / Glycol Cooled Head Pressure Control

DX - Water/Glycol Reg. Valves (Factory Installed!)



- 2-Way, 350 psig Reg. Valve
- 3-Way, 350 psig Reg. Valve

System head pressure shall be controlled by a factory provided ___-Way electronic modulating (0-10Vdc) water / glycol regulating valve rated for ___ psig w.w.p.

Free-Cooling / Dual-Cool Coil Control Valves

Chilled Water Control Valves



Modulating Valves, 0-10Vdc:

- 2-Way, 580 psig (0-10Vdc, NC)
- 3-Way, 580 psig (0-10Vdc, NC)

A ___-way free-cooling (or dual cool) coil control valve shall be factory installed within the air conditioning unit. The valve shall provide precision space cooling and/or dehumidification control. The valve shall be the 24 VAC, ___-Way, Modulating (0-10Vdc), normally closed type.

Hot Gas Bypass Systems

Hot Gas Bypass To Evap Inlet



The lead refrigerant circuit shall be provided with a factory installed hot gas (discharge) bypass valve. The hot gas bypass valve shall be designed to supply hot gas to evaporator inlet as required to provide coil freeze-protection and capacity modulation under low load conditions

Suction-Line Accumulators



Each refrigerant circuit shall be provided with a factory installed Suction-Line Accumulator to prevent liquid slugging of the compressor and excessive refrigerant dilution of the compressor oil during low load conditions. The accumulator shall return refrigerant and oil to the compressor at a sufficient rate to maintain both system operating efficiency and proper oil level. The accumulators shall be wrapped with 1/2" closed-cell neoprene insulation to prevent sweating.

CONTROL OPTIONS

MC-2000™, Advanced Temp/Humid Microprocessor Controller w/ Alarms & BMS Connection



The system shall be provided with a MC-2000™ advanced microprocessor based temperature and humidity controller with alarms.

Select Features/Benefits:

- 4x20 Character Liquid Crystal Alpha-numerical Display
- User Configurable
- Run-Time Hours
- Current Unit Mode Status
- Alarm Status
- Digital & Analog Inputs / Outputs
- Temperature Anticipation
- Remote Stop / Start Contact

- Summary Alarm Contact
- Automatic or Manual (selectable) Restart After Power Loss
- Sequential Load After Restart
- Recovery Delay
- Compressor Short Cycle Timers
- Cold Start Time Delay
- Security Password Access
- Self-Diagnostics
- Service Mode

Unit Status Display

The control system shall display current unit functions and room status (if applicable):

- Current Dry Bulb Temp Set Point
- Current Relative Humidity Set Point
- System ON/OFF
- Cooling
- Heating
- Humidifying
- Dehumidifying
- Reheating
- Actual Room DB Temperature
- Actual Room Relative Humidity

Alarm Conditions:

Alarm conditions activate an audible and visual indicator plus close a summary alarm dry contact connection. The control system shall alert to the following alarm conditions (if applicable):

- High Temperature
- Low Temperature
- High Humidity
- Low Humidity
- Sensor Failure
- Summary Failure
- Loss of Air Flow
- High Head Press
- Smoke Detection
- Firestat
- Leak Detection
- Loss of Power
- Dirty Filter
- Loss of Fluid Flow

Digital & Analog Control Inputs / Outputs:

The control system shall be capable of both digital (ON/OFF) and analog (proportional integral, PI) input and output control.

Select MC-2000 Options:

- Multi-Unit N+1 Sequencing
- BMS Communications Interface:
 - BACnet over MS/TP (RS485 Serial)
 - BACnet Over IP (Ethernet / EIA485)
 - ModBus RS485 Serial Connection

Heat / Reheat Options

HEAT OPTIONS

Electric Reheat/Heat



An electric heating system shall be factory installed to provide:

- Electric Heat Only during heat mode
- Electric Reheat to offset sensible cooling during the dehumidification mode and to provide heating during heat mode.

Heater elements shall be the low-watt density finned-tubular type. The heater shall be complete with individual heater stage starter/contactors and overheat safeties. Systems incorporating factory installed electric heaters shall require only single point power to the main unit power distribution. The electric heat shall have a capacity of _____ BTU/H and a KW rating of ____ KW, controlled in ____ stages.

SCR Fired Heat/Reheat (0-100% Modulating 0-10Vdc)

The electric heat/reheat shall be controlled through a "zero firing" silicon control rectifier (SCR) with an extruded aluminum heat sink and solid state logic system to provide close dry bulb temperature control of the leaving conditioned air temperature. The electric heat shall have a capacity of _____ BTUH and a KW rating of ____ KW.

Hot Gas Reheat



The system shall be provided with a hot gas reheat coil with 3-way heat reclaim control valve. The hot gas reheat coil shall provide free-energy space neutral leaving air temperature by offsetting the sensible cooling during dx dehumidification operation.

(Note: Modulating (0-10Vdc) Hot Gas Reheat valves are optionally available.)

Humidification Options

Steam Humidification



An electrode steam canister type humidification system shall be factory installed within the air conditioning system. The humidifier shall be complete with dispos-

able canister, steam distributor, fill and drain valve, air gap, automatic flush cycle, manual humidity output adjustment and field installed remote wall mounted humidistat. The humidifier shall have a maximum output capacity of _____ lbs/hr.

Accessories

Plenum Discharge Box (UF - Up-Flow Units)

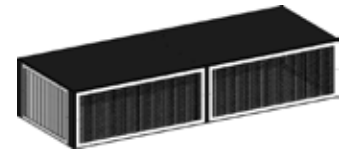

A 3-Way (or 2-Way) plenum discharge box shall be provided for field installation to the top of the up-flow unit. The plenum box shall be insulated and powder-coat painted to match the color of the unit. The plenum box supply grilles shall be the double deflection type with vertical blades in the front, horizontal blades in the back; both individually adjustable and on 2/3" spacing; aluminum roll-formed blade with semi-airfoil design; pressure fit nylon pivot pins (rattle free & non-loosening) and an aluminum extruded frame with mechanically locked corners.

Floor Stand



A ____ inch nominal high (____ in to ____ in adj. range) floor stand shall be factory provided for field installation. The floor stand shall have adjustable legs with vibration isolation.

(Note: Seismic Rated Floor Stands are optionally available.)

Turning Vanes

Turning vanes shall be factory provided with the floor stand to direct the discharge air either to the front or rear of the unit.

Condensate Pump (Factory Installed - Both UF & DF!)



A condensate pump shall be factory provided and installed within the indoor evaporator section (Up-Flow & Down-

Flow Air Pattern Configurations). The condensate pump shall be provided with dual internal float switches: one for pump operation initiation and the other for pump reservoir overflow safety.

Main Power, Non-Fused Disconnect (Remote Condenser Section)



The remote condenser shall be factory provided with a main power non-fused disconnect for field installation. The disconnect shall be NEMA rated for indoor or outdoor installation as required.

Remote Water-Leak Detector



A remote water-leak detector shall be factory provided for field installation. The remote water-leak detector shall be wired to shut down all A/C unit water producing functions upon sensing a water leak.

(Note: Cable Type Remote Water Detectors are also optionally available.)

Flow Switch - Condenser Water



A factory installed flow switch shall shut-down / lockout compressor operation prior to a high refrigerant pressure switch alarm upon sensing a loss or low dx condenser water/glycol flow. The flow switch alarm shall be indicated both via MC-2000 microprocessor display and auxiliary dry-contact terminal connection.

Low Entering Condenser Water / Glycol Kit to 45°F EWT/EGT

A low enter condenser water/glycol kit shall be provided with liquid refrigerant receiver, compressor crankcase heater, insulated wrapped condenser and unit internal condenser water/glycol piping. The Low EWT/EGT kit shall allow for continued winter A/C operation when condenser source water/glycol drops below 65°F (down to 45°F).

Smoke Detector (Factory Installed)



A Smoke Detector shall be factory installed in the return air stream of the unit and wired to the A/C unit electrical control panel. The Smoke Detector shall shut-down all A/C system operations upon activation.

Firestat (Factory Installed)



A Firestat shall be factory installed in the return air stream of the unit and wired to the A/C unit electrical control panel. The Firestat shall shut-down all A/C system operations upon sensing a high return air temperature condition.

Hose Kits - Automatic



Condenser water/glycol hose kits shall be factory provided. Each kit shall include the piping specialties necessary to ensure a proper installation: a Hays 2500 Series Mesurflo Automatic Flow Control Valve, two 36" flexible hoses, ball valves on the return and supply sides with P/T Ports, high flow "Y-ball" strainers for sizes 1/2"-2" and a manual air vent on the return. Hose materials shall be the reinforced and bonded EPDM rubber type with a temperature rating of 32°F to 225°F and a working pressure of 400 psig. Minimum burst pressure shall be four (4) times the working pressure at maximum rated temperature. The hoses shall have stainless steel braid over an EPDM liner. The "Y-Ball" strainers shall have a stainless steel 20 mesh screen that is easily accessible for cleaning without disconnecting the hoses.

Mounting Vibration Isolators

Rubber/Cork Anti-Vibration Pads:



Each indoor vertical floor mounted section shall be provided with a set of quantity four (4"x4"x7/8") Rubber/Cork Anti-Vibration Pad vibration mounting isolators.

Spring Mounting Isolators:



Each indoor vertical floor mounted section shall be provided with a set of quantity four adjustable spring vibration mounting isolators with non-skid neoprene acoustical isolation pads. Isolators shall be sized for the total distributive weight of the unit with a 1" deflection.

Compressor Sound Jackets



Each compressor shall be provided with a factory installed compressor sound jacket with a snap closure system for ease of removal and reinstallation. Sound jackets shall have a noise reduction coefficient (NRC) of 0.85 per ASTM (C423) and a sound transmission class/loss (STC) of 11 per ASTM E-90.

DX - Air Cooled, Cooling Capacities (21-105kW, 6-30 Tons)

Nominal Size	21kW (6.0T)	28kW (8.0T)	35kW (10.0T)	42kW (12.0T)	53kW (15.0T)
Up-Flow Model:	MCE-021D*-UF	MCE-028D*-UF	MCE-035D*-UF	MCE-042D*-UF	MCE-053D*-UF
Cabinet Size:	A-Cabinet			B-Cabinet	

UP-FLOW	Airflow Rate	CFM (CMH)	3,000 (5,097)	4,000 (6,796)	5,000 (8,495)	6,000 (10,194)	7,500 (12,743)	
	Net Cooling Capacity MBH (kW)							
	85°F DB / 64.4°F WB, 52°F DP, (29.4°C DB / 18°C WB) 32% RH							
	Total	MBH (kW)	88.5 (25.9)	109.6 (32.1)	132.0 (38.7)	171.4 (50.2)	198.2 (58.1)	
	Sensible	MBH (kW)	88.5 (25.9)	109.6 (32.1)	132.0 (38.7)	171.4 (50.2)	198.2 (58.1)	
	Efficiency Rating	SCOP	3.15	3.52	3.49	3.62	3.35	
	75°F DB / 62.5°F WB, 55.1°F DP, (23.9°C DB / 16.9°C WB) 50% RH							
	Total	MBH (kW)	83.7 (24.5)	102.6 (30.1)	123.5 (36.2)	162.5 (47.6)	186.1 (54.5)	
	Sensible	MBH (kW)	67.9 (19.9)	85.1 (24.9)	102.7 (30.1)	131.0 (38.4)	154.2 (45.2)	
	75°F DB / 61°F WB, 52°F DP, (23.9°C DB / 16.1°C WB) 44.6% RH							
Total	MBH (kW)	81.6 (23.9)	100.1 (29.3)	120.6 (35.3)	158.3 (46.4)	181.7 (53.3)		
Sensible	MBH (kW)	72.6 (21.3)	91.6 (26.8)	111.0 (32.5)	140.3 (41.1)	166.4 (48.8)		
72°F DB / 60°F WB, 52°F DP, (22.2°C DB / 15.6°C WB) 50% RH								
Total	MBH (kW)	79.8 (23.4)	97.7 (28.6)	117.7 (34.5)	155.1 (45.5)	177.8 (52.1)		
Sensible	MBH (kW)	66.6 (19.5)	83.4 (24.4)	100.8 (29.5)	128.7 (37.7)	151.6 (44.4)		

Down-Flow Model:	MCE-021D*-DF	MCE-028D*-DF	MCE-035D*-DF	MCE-042D*-DF	MCE-053D*-DF
Cabinet Size:	A-Cabinet			B-Cabinet	

DOWN-FLOW	Airflow Rate	CFM (CMH)	3,000 (5,097)	4,000 (6,796)	5,000 (8,495)	6,000 (10,194)	7,500 (12,743)	
	Net Cooling Capacity MBH (kW)							
	85°F DB / 64.4°F WB, 52°F DP, (29.4°C DB / 18°C WB) 32% RH							
	Total	MBH (kW)	89.0 (26.1)	110.3 (32.3)	132.8 (38.9)	172.3 (50.5)	199.4 (58.4)	
	Sensible	MBH (kW)	89.0 (26.1)	110.3 (32.3)	132.8 (38.9)	172.3 (50.5)	199.4 (58.4)	
	Efficiency Rating	SCOP	3.16	3.54	3.65	3.74	3.44	
	75°F DB / 62.5°F WB, 55.1°F DP, (23.9°C DB / 16.9°C WB) 50% RH							
	Total	MBH (kW)	84.2 (24.7)	103.2 (30.2)	124.3 (36.4)	163.5 (47.9)	187.3 (54.9)	
	Sensible	MBH (kW)	68.3 (20.0)	85.7 (25.1)	103.5 (30.3)	131.9 (38.7)	155.4 (45.5)	
	75°F DB / 61°F WB, 52°F DP, (23.9°C DB / 16.1°C WB) 44.6% RH							
Total	MBH (kW)	82.0 (24.0)	100.7 (29.5)	121.4 (35.6)	159.3 (46.7)	182.9 (53.6)		
Sensible	MBH (kW)	73.1 (21.4)	92.2 (27.0)	111.8 (32.8)	141.2 (41.4)	167.6 (49.1)		
72°F DB / 60°F WB, 52°F DP, (22.2°C DB / 15.6°C WB) 50% RH								
Total	MBH (kW)	80.3 (23.5)	98.4 (28.8)	118.5 (34.7)	156.1 (45.7)	179.0 (52.5)		
Sensible	MBH (kW)	67.0 (19.6)	84.0 (24.6)	101.6 (29.8)	129.6 (38.0)	152.8 (44.8)		

Nominal Size	63kW (18.0T)	70kW (20.0T)	88kW (25.0T)	97kW (27.5T)	105kW (30.0T)
Up-Flow Model:	MCE-063D*-UF	MCE-070D*-UF	MCE-088D*-UF	MCE-097D*-UF	MCE-105D*-UF
Cabinet Size:	C-Cabinet		D-Cabinet	E-Cabinet	

UP-FLOW	Airflow Rate	CFM (CMH)	9,000 (15,291)	10,000 (16,990)	12,500 (21,238)	13,750 (23,361)	15,000 (25,485)	
	Net Cooling Capacity MBH (kW)							
	85°F DB / 64.4°F WB, 52°F DP, (29.4°C DB / 18°C WB) 32% RH							
	Total	MBH (kW)	249.2 (73.0)	285.1 (83.6)	323.7 (94.9)	365.9 (107.2)	414.0 (121.3)	
	Sensible	MBH (kW)	248.9 (72.9)	285.1 (83.6)	323.7 (94.9)	365.8 (107.2)	414.0 (121.3)	
	Efficiency Rating	SCOP	3.12	2.94	2.77	2.89	2.71	
	75°F DB / 62.5°F WB, 55.1°F DP, (23.9°C DB / 16.9°C WB) 50% RH							
	Total	MBH (kW)	233.5 (68.4)	269.6 (79.0)	302.7 (88.7)	343.6 (100.7)	393.4 (115.3)	
	Sensible	MBH (kW)	194.2 (56.9)	216.8 (63.5)	260.7 (76.4)	290.3 (85.1)	319.5 (93.6)	
	75°F DB / 61°F WB, 52°F DP, (23.9°C DB / 16.1°C WB) 44.6% RH							
Total	MBH (kW)	229.5 (67.3)	265.6 (77.8)	295.5 (86.6)	336.3 (98.6)	386.4 (113.2)		
Sensible	MBH (kW)	215.4 (63.1)	242.6 (71.1)	284.0 (83.2)	320.9 (94.0)	359.1 (105.2)		
72°F DB / 60°F WB, 52°F DP, (22.2°C DB / 15.6°C WB) 50% RH								
Total	MBH (kW)	223.2 (65.4)	257.7 (75.5)	289.0 (84.7)	328.3 (96.2)	376.2 (110.3)		
Sensible	MBH (kW)	192.0 (56.3)	214.3 (62.8)	257.4 (75.4)	286.8 (84.1)	316.6 (92.8)		

Down-Flow Model:	MCE-063D*-DF	MCE-070D*-DF	MCE-088D*-DF	MCE-097D*-DF	MCE-105D*-DF
Cabinet Size:	C-Cabinet		D-Cabinet	E-Cabinet	

DOWN-FLOW	Airflow Rate	CFM (CMH)	9,000 (15,291)	10,000 (16,990)	12,500 (21,238)	13,750 (23,361)	15,000 (25,485)	
	Net Cooling Capacity MBH (kW)							
	85°F DB / 64.4°F WB, 52°F DP, (29.4°C DB / 18°C WB) 32% RH							
	Total	MBH (kW)	250.6 (73.4)	286.7 (84.0)	325.7 (95.5)	368.1 (107.9)	416.4 (122.0)	
	Sensible	MBH (kW)	250.3 (73.4)	286.7 (84.0)	325.7 (95.5)	368.0 (107.9)	416.4 (122.0)	
	Efficiency Rating	SCOP	3.33	3.20	2.91	3.00	2.78	
	75°F DB / 62.5°F WB, 55.1°F DP, (23.9°C DB / 16.9°C WB) 50% RH							
	Total	MBH (kW)	235.0 (68.9)	271.2 (79.5)	304.7 (89.3)	345.8 (101.3)	395.8 (116.0)	
	Sensible	MBH (kW)	195.6 (57.3)	218.4 (64.0)	262.7 (77.0)	292.5 (85.7)	321.8 (94.3)	
	75°F DB / 61°F WB, 52°F DP, (23.9°C DB / 16.1°C WB) 44.6% RH							
Total	MBH (kW)	230.9 (67.7)	267.2 (78.3)	297.5 (87.2)	338.5 (99.2)	388.8 (113.9)		
Sensible	MBH (kW)	216.8 (63.5)	244.2 (71.6)	286.0 (83.8)	323.1 (94.7)	361.4 (105.9)		
72°F DB / 60°F WB, 52°F DP, (22.2°C DB / 15.6°C WB) 50% RH								
Total	MBH (kW)	224.7 (65.9)	259.3 (76.0)	291.0 (85.3)	330.4 (96.8)	378.6 (111.0)		
Sensible	MBH (kW)	193.4 (56.7)	215.9 (63.3)	259.4 (76.0)	289.0 (84.7)	319.0 (93.5)		

Cooling Capacity Data - MC2-DX, Water Cooled (21-105kW, 6-30 Tons)

DX - Water Cooled, Cooling Capacities (21-105kW, 6-30 Tons)

Nominal Size	21kW (6.0T)	28kW (8.0T)	35kW (10.0T)	42kW (12.0T)	53kW (15.0T)
Up-Flow Model:	MCW-021D-*-UF	MCW-028D-*-UF	MCW-035D-*-UF	MCW-042D-*-UF	MCW-053D-*-UF
Cabinet Size:	A-Cabinet			B-Cabinet	

UP-FLOW

Airflow Rate	CFM (CMH)	3,000 (5,097)	4,000 (6,796)	5,000 (8,495)	6,000 (10,194)	7,500 (12,743)
Net Cooling Capacity MBH (kW)						
85°F DB / 64.4°F WB, 52°F DP, (29.4°C DB / 18°C WB) 32% RH						
Total	MBH (kW)	92.3 (27.1)	113.8 (33.4)	137.1 (40.2)	178.0 (52.2)	205.3 (60.2)
Sensible	MBH (kW)	92.2 (27.0)	113.8 (33.4)	137.1 (40.2)	178.0 (52.2)	205.3 (60.2)
Efficiency Rating	SCOP	3.88	4.12	4.08	3.86	3.73
75°F DB / 62.5°F WB, 55.1°F DP, (23.9°C DB / 16.9°C WB) 50% RH						
Total	MBH (kW)	88.2 (25.8)	107.6 (31.5)	129.7 (38.0)	170.5 (50.0)	194.8 (57.1)
Sensible	MBH (kW)	69.7 (20.4)	86.9 (25.5)	104.9 (30.7)	134.3 (39.4)	157.2 (46.1)
75°F DB / 61°F WB, 52°F DP, (23.9°C DB / 16.1°C WB) 44.6% RH						
Total	MBH (kW)	85.8 (25.1)	104.8 (30.7)	126.4 (37.0)	166.2 (48.7)	189.8 (55.6)
Sensible	MBH (kW)	74.3 (21.8)	93.1 (27.3)	112.5 (33.0)	143.7 (42.1)	168.5 (49.4)
72°F DB / 60°F WB, 52°F DP, (22.2°C DB / 15.6°C WB) 50% RH						
Total	MBH (kW)	84.1 (24.6)	102.6 (30.1)	123.7 (36.3)	162.7 (47.7)	186.0 (54.5)
Sensible	MBH (kW)	68.4 (20.0)	85.3 (25.0)	102.9 (30.2)	131.8 (38.6)	154.4 (45.3)

Down-Flow Model:	MCW-021D-*-DF	MCW-028D-*-DF	MCW-035D-*-DF	MCW-042D-*-DF	MCW-053D-*-DF
Cabinet Size:	A-Cabinet			B-Cabinet	

DOWN-FLOW

Airflow Rate	CFM (CMH)	3,000 (5,097)	4,000 (6,796)	5,000 (8,495)	6,000 (10,194)	7,500 (12,743)
Net Cooling Capacity MBH (kW)						
85°F DB / 64.4°F WB, 52°F DP, (29.4°C DB / 18°C WB) 32% RH						
Total	MBH (kW)	92.7 (27.2)	114.4 (33.5)	137.9 (40.4)	179.0 (52.5)	206.5 (60.5)
Sensible	MBH (kW)	92.7 (27.2)	114.4 (33.5)	137.9 (40.4)	179.0 (52.5)	206.5 (60.5)
Efficiency Rating	SCOP	3.89	4.14	4.19	3.93	3.78
75°F DB / 62.5°F WB, 55.1°F DP, (23.9°C DB / 16.9°C WB) 50% RH						
Total	MBH (kW)	88.6 (26.0)	108.2 (31.7)	130.5 (38.2)	171.5 (50.3)	195.9 (57.4)
Sensible	MBH (kW)	70.1 (20.5)	87.6 (25.7)	105.7 (31.0)	135.2 (39.6)	158.4 (46.4)
75°F DB / 61°F WB, 52°F DP, (23.9°C DB / 16.1°C WB) 44.6% RH						
Total	MBH (kW)	86.3 (25.3)	105.5 (30.9)	127.2 (37.3)	167.2 (49.0)	191.0 (56.0)
Sensible	MBH (kW)	74.8 (21.9)	93.7 (27.5)	113.3 (33.2)	144.6 (42.4)	169.6 (49.7)
72°F DB / 60°F WB, 52°F DP, (22.2°C DB / 15.6°C WB) 50% RH						
Total	MBH (kW)	84.6 (24.8)	103.2 (30.2)	124.5 (36.5)	163.6 (47.9)	187.2 (54.9)
Sensible	MBH (kW)	68.9 (20.2)	86.0 (25.2)	103.7 (30.4)	132.8 (38.9)	155.6 (45.6)

Nominal Size	63kW (18.0T)	70kW (20.0T)	88kW (25.0T)	97kW (27.5T)	105kW (30.0T)
Up-Flow Model:	MCW-063D-*-UF	MCW-070D-*-UF	MCW-088D-*-UF	MCW-097D-*-UF	MCW-105D-*-UF
Cabinet Size:	C-Cabinet		D-Cabinet	E-Cabinet	

UP-FLOW

Airflow Rate	CFM (CMH)	9,000 (15,291)	10,000 (16,990)	12,500 (21,238)	13,750 (23,361)	15,000 (25,485)
Net Cooling Capacity MBH (kW)						
85°F DB / 64.4°F WB, 52°F DP, (29.4°C DB / 18°C WB) 32% RH						
Total	MBH (kW)	257.9 (75.6)	295.1 (86.5)	335.8 (98.4)	379.3 (111.2)	427.5 (125.3)
Sensible	MBH (kW)	257.9 (75.6)	289.5 (84.8)	335.8 (98.4)	379.3 (111.2)	427.5 (125.3)
Efficiency Rating	SCOP	3.71	3.60	3.51	3.60	3.45
75°F DB / 62.5°F WB, 55.1°F DP, (23.9°C DB / 16.9°C WB) 50% RH						
Total	MBH (kW)	243.1 (71.2)	281.3 (82.4)	316.6 (92.8)	358.4 (105.0)	408.9 (119.8)
Sensible	MBH (kW)	195.9 (57.4)	220.5 (64.6)	262.5 (76.9)	291.9 (85.5)	321.5 (94.2)
75°F DB / 61°F WB, 52°F DP, (23.9°C DB / 16.1°C WB) 44.6% RH						
Total	MBH (kW)	239.6 (70.2)	277.1 (81.2)	310.7 (91.1)	352.2 (103.2)	402.4 (117.9)
Sensible	MBH (kW)	218.6 (64.1)	244.5 (71.7)	293.6 (86.0)	327.2 (95.9)	361.5 (105.9)
72°F DB / 60°F WB, 52°F DP, (22.2°C DB / 15.6°C WB) 50% RH						
Total	MBH (kW)	232.4 (68.1)	268.5 (78.7)	302.5 (88.7)	342.4 (100.3)	391.1 (114.6)
Sensible	MBH (kW)	193.5 (56.7)	216.4 (63.4)	259.8 (76.1)	288.9 (84.7)	318.3 (93.3)

Down-Flow Model:	MCW-063D-*-DF	MCW-070D-*-DF	MCW-088D-*-DF	MCW-097D-*-DF	MCW-105D-*-DF
Cabinet Size:	C-Cabinet		D-Cabinet	E-Cabinet	

DOWN-FLOW

Airflow Rate	CFM (CMH)	9,000 (15,291)	10,000 (16,990)	12,500 (21,238)	13,750 (23,361)	15,000 (25,485)
Net Cooling Capacity MBH (kW)						
85°F DB / 64.4°F WB, 52°F DP, (29.4°C DB / 18°C WB) 32% RH						
Total	MBH (kW)	259.4 (76.0)	296.7 (87.0)	337.8 (99.0)	381.5 (111.8)	429.8 (126.0)
Sensible	MBH (kW)	259.4 (76.0)	291.1 (85.3)	337.8 (99.0)	381.5 (111.8)	429.8 (126.0)
Efficiency Rating	SCOP	3.84	3.77	3.61	3.68	3.50
75°F DB / 62.5°F WB, 55.1°F DP, (23.9°C DB / 16.9°C WB) 50% RH						
Total	MBH (kW)	244.5 (71.7)	282.9 (82.9)	318.6 (93.4)	360.6 (105.7)	411.3 (120.5)
Sensible	MBH (kW)	197.4 (57.9)	222.1 (65.1)	264.5 (77.5)	294.1 (86.2)	323.9 (94.9)
75°F DB / 61°F WB, 52°F DP, (23.9°C DB / 16.1°C WB) 44.6% RH						
Total	MBH (kW)	241.0 (70.6)	278.7 (81.7)	312.7 (91.6)	354.4 (103.9)	404.8 (118.6)
Sensible	MBH (kW)	220.0 (64.5)	246.1 (72.1)	295.5 (86.6)	329.4 (96.5)	363.8 (106.6)
72°F DB / 60°F WB, 52°F DP, (22.2°C DB / 15.6°C WB) 50% RH						
Total	MBH (kW)	233.9 (68.5)	270.1 (79.2)	304.5 (89.2)	344.6 (101.0)	393.5 (115.3)
Sensible	MBH (kW)	195.0 (57.1)	218.0 (63.9)	261.8 (76.7)	291.1 (85.3)	320.7 (94.0)

Cooling Capacity Data

DX - Glycol Cooled, Cooling Capacities (21-105kW, 6-30 Tons)

Nominal Size	21kW (6.0T)	28kW (8.0T)	35kW (10.0T)	42kW (12.0T)	53kW (15.0T)
Up-Flow Model:	MCG-021D*-UF	MCG-028D*-UF	MCG-035D*-UF	MCG-042D*-UF	MCG-053D*-UF
Cabinet Size:	A-Cabinet			B-Cabinet	

UP-FLOW	Airflow Rate	CFM (CMH)	3,000 (5,097)	4,000 (6,796)	5,000 (8,495)	6,000 (10,194)	7,500 (12,743)	
	Net Cooling Capacity MBH (kW)							
	85°F DB / 64.4°F WB, 52°F DP, (29.4°C DB / 18°C WB) 32% RH							
	Total	MBH (kW)	82.2 (24.1)	102.1 (29.9)	122.4 (35.9)	159.8 (46.8)	184.6 (54.1)	
	Sensible	MBH (kW)	82.2 (24.1)	102.1 (29.9)	122.4 (35.9)	159.8 (46.8)	184.6 (54.1)	
	Efficiency Rating	SCOP	2.40	2.61	2.60	2.53	2.43	
	75°F DB / 62.5°F WB, 55.1°F DP, (23.9°C DB / 16.9°C WB) 50% RH							
	Total	MBH (kW)	76.3 (22.4)	93.6 (27.4)	112.1 (32.9)	148.7 (43.6)	170.0 (49.8)	
	Sensible	MBH (kW)	64.8 (19.0)	81.5 (23.9)	98.2 (28.8)	125.4 (36.8)	148.3 (43.5)	
	75°F DB / 61°F WB, 52°F DP, (23.9°C DB / 16.1°C WB) 44.6% RH							
Total	MBH (kW)	74.6 (21.9)	91.8 (26.9)	109.8 (32.2)	145.2 (42.6)	166.2 (48.7)		
Sensible	MBH (kW)	69.3 (20.3)	89.0 (26.1)	107.4 (31.5)	138.3 (40.5)	160.1 (46.9)		
72°F DB / 60°F WB, 52°F DP, (22.2°C DB / 15.6°C WB) 50% RH								
Total	MBH (kW)	72.6 (21.3)	89.0 (26.1)	106.7 (31.3)	141.8 (41.6)	162.0 (47.5)		
Sensible	MBH (kW)	63.3 (18.6)	79.2 (23.2)	95.4 (28.0)	123.0 (36.0)	144.3 (42.3)		

Down-Flow Model:	MCG-021D*-DF	MCG-028D*-DF	MCG-035D*-DF	MCG-042D*-DF	MCG-053D*-DF
Cabinet Size:	A-Cabinet			B-Cabinet	

DOWN-FLOW	Airflow Rate	CFM (CMH)	3,000 (5,097)	4,000 (6,796)	5,000 (8,495)	6,000 (10,194)	7,500 (12,743)	
	Net Cooling Capacity MBH (kW)							
	85°F DB / 64.4°F WB, 52°F DP, (29.4°C DB / 18°C WB) 32% RH							
	Total	MBH (kW)	82.7 (24.2)	102.7 (30.1)	123.2 (36.1)	160.8 (47.1)	185.8 (54.5)	
	Sensible	MBH (kW)	82.7 (24.2)	102.7 (30.1)	123.2 (36.1)	160.8 (47.1)	185.8 (54.5)	
	Efficiency Rating	SCOP	2.41	2.63	2.69	2.59	2.48	
	75°F DB / 62.5°F WB, 55.1°F DP, (23.9°C DB / 16.9°C WB) 50% RH							
	Total	MBH (kW)	76.7 (22.5)	94.2 (27.6)	112.9 (33.1)	149.7 (43.9)	171.2 (50.2)	
	Sensible	MBH (kW)	65.3 (19.1)	82.2 (24.1)	99.0 (29.0)	126.4 (37.0)	149.5 (43.8)	
	75°F DB / 61°F WB, 52°F DP, (23.9°C DB / 16.1°C WB) 44.6% RH							
Total	MBH (kW)	75.1 (22.0)	92.5 (27.1)	110.6 (32.4)	146.2 (42.8)	167.4 (49.1)		
Sensible	MBH (kW)	69.8 (20.5)	89.6 (26.3)	108.2 (31.7)	139.2 (40.8)	161.3 (47.3)		
72°F DB / 60°F WB, 52°F DP, (22.2°C DB / 15.6°C WB) 50% RH								
Total	MBH (kW)	73.1 (21.4)	89.7 (26.3)	107.4 (31.5)	142.8 (41.9)	163.2 (47.8)		
Sensible	MBH (kW)	63.8 (18.7)	79.9 (23.4)	96.1 (28.2)	124.0 (36.3)	145.5 (42.6)		

Nominal Size	63kW (18.0T)	70kW (20.0T)	88kW (25.0T)	97kW (27.5T)	105kW (30.0T)
Up-Flow Model:	MCG-063D*-UF	MCG-070D*-UF	MCG-088D*-UF	MCG-097D*-UF	MCG-105D*-UF
Cabinet Size:	C-Cabinet		D-Cabinet	E-Cabinet	

UP-FLOW	Airflow Rate	CFM (CMH)	9,000 (15,291)	10,000 (16,990)	12,500 (21,238)	13,750 (23,361)	15,000 (25,485)	
	Net Cooling Capacity MBH (kW)							
	85°F DB / 64.4°F WB, 52°F DP, (29.4°C DB / 18°C WB) 32% RH							
	Total	MBH (kW)	232.0 (68.0)	263.8 (77.3)	299.3 (87.7)	338.8 (99.3)	383.6 (112.4)	
	Sensible	MBH (kW)	232.0 (68.0)	263.8 (77.3)	299.3 (87.7)	338.8 (99.3)	383.6 (112.4)	
	Efficiency Rating	SCOP	2.36	2.26	2.19	2.30	2.19	
	75°F DB / 62.5°F WB, 55.1°F DP, (23.9°C DB / 16.9°C WB) 50% RH							
	Total	MBH (kW)	214.4 (62.8)	245.8 (72.0)	274.5 (80.4)	313.1 (91.8)	359.2 (105.3)	
	Sensible	MBH (kW)	188.5 (55.2)	210.2 (61.6)	250.4 (73.4)	280.2 (82.1)	310.0 (90.9)	
	75°F DB / 61°F WB, 52°F DP, (23.9°C DB / 16.1°C WB) 44.6% RH							
Total	MBH (kW)	209.6 (61.4)	239.8 (70.3)	268.8 (78.8)	305.9 (89.7)	349.9 (102.5)		
Sensible	MBH (kW)	205.6 (60.3)	229.3 (67.2)	268.8 (78.8)	305.9 (89.7)	337.6 (98.9)		
72°F DB / 60°F WB, 52°F DP, (22.2°C DB / 15.6°C WB) 50% RH								
Total	MBH (kW)	204.5 (59.9)	234.2 (68.6)	261.4 (76.6)	298.7 (87.5)	342.8 (100.5)		
Sensible	MBH (kW)	185.4 (54.3)	207.1 (60.7)	244.5 (71.7)	275.5 (80.7)	306.0 (89.7)		

Down-Flow Model:	MCG-063D*-DF	MCG-070D*-DF	MCG-088D*-DF	MCG-097D*-DF	MCG-105D*-DF
Cabinet Size:	C-Cabinet		D-Cabinet	E-Cabinet	

DOWN-FLOW	Airflow Rate	CFM (CMH)	9,000 (15,291)	10,000 (16,990)	12,500 (21,238)	13,750 (23,361)	15,000 (25,485)	
	Net Cooling Capacity MBH (kW)							
	85°F DB / 64.4°F WB, 52°F DP, (29.4°C DB / 18°C WB) 32% RH							
	Total	MBH (kW)	233.4 (68.4)	265.4 (77.8)	301.3 (88.3)	341.0 (99.9)	386.0 (113.1)	
	Sensible	MBH (kW)	233.4 (68.4)	265.4 (77.8)	301.3 (88.3)	341.0 (99.9)	386.0 (113.1)	
	Efficiency Rating	SCOP	2.48	2.41	2.27	2.36	2.22	
	75°F DB / 62.5°F WB, 55.1°F DP, (23.9°C DB / 16.9°C WB) 50% RH							
	Total	MBH (kW)	215.8 (63.2)	247.3 (72.5)	276.5 (81.0)	315.3 (92.4)	361.6 (106.0)	
	Sensible	MBH (kW)	189.9 (55.7)	211.8 (62.1)	252.4 (74.0)	282.4 (82.8)	312.4 (91.6)	
	75°F DB / 61°F WB, 52°F DP, (23.9°C DB / 16.1°C WB) 44.6% RH							
Total	MBH (kW)	211.0 (61.8)	241.4 (70.7)	270.7 (79.3)	308.1 (90.3)	352.3 (103.2)		
Sensible	MBH (kW)	207.0 (60.7)	230.9 (67.7)	270.7 (79.3)	308.1 (90.3)	340.0 (99.6)		
72°F DB / 60°F WB, 52°F DP, (22.2°C DB / 15.6°C WB) 50% RH								
Total	MBH (kW)	206.0 (60.4)	235.8 (69.1)	263.4 (77.2)	300.9 (88.2)	345.2 (101.2)		
Sensible	MBH (kW)	186.8 (54.7)	208.7 (61.2)	246.5 (72.2)	277.7 (81.4)	308.4 (90.4)		

Dual-Cool Coil, Cooling Capacity Data - MC2-DX (21-105kW)

Dual Cool Coil (45°F EWT / 55°F LWT) Cooling Capacities (21-105kW, 6-30 Tons)

Nominal Size	21kW (6.0T)	28kW (8.0T)	35kW (10.0T)	42kW (12.0T)	53kW (15.0T)
Up-Flow Model:	MC_-021D*-DC-UF	MC_-028D*-DC-UF	MC_-035D*-DC-UF	MC_-042D*-DC-UF	MC_-053D*-DC-UF
Cabinet Size:	A-Cabinet			B-Cabinet	

UP-FLOW

Airflow Rate	CFM (CMH)	3,000 (5,097)	4,000 (6,796)	5,000 (8,495)	6,000 (10,194)	7,500 (12,743)
Net Cooling Capacity MBH (kW)						
75°F DB / 62.5°F WB, 55.1°F DP, (23.9°C DB / 16.9°C WB) 50% RH						
Total	MBH (kW)	83.1 (24.4)	101.6 (29.8)	117.9 (34.6)	153.1 (44.9)	177.5 (52.0)
Sensible	MBH (kW)	68.5 (20.1)	86.4 (25.3)	102.9 (30.2)	129.7 (38.0)	154.5 (45.3)
Flow Rate	GPM (l/m)	17.0 (64.4)	20.9 (79.1)	24.4 (92.4)	31.5 (119.2)	36.7 (138.9)
Coil Fluid PD	FT WG (kPa)	6.5 (19.4)	9.7 (29.0)	8.9 (26.6)	10.5 (31.4)	10.4 (31.1)
72°F DB / 60°F WB, 52°F DP, (22.2°C DB / 15.6°C WB) 50% RH						
Total	MBH (kW)	66.5 (19.5)	81.8 (24.0)	95.5 (28.0)	123.3 (36.1)	143.8 (42.1)
Sensible	MBH (kW)	61.6 (18.1)	78.1 (22.9)	93.6 (27.4)	117.3 (34.4)	140.4 (41.1)
Flow Rate	GPM (l/m)	13.7 (51.9)	16.9 (64.0)	19.9 (75.3)	25.5 (96.5)	29.9 (113.2)
Coil Fluid PD	FT WG (kPa)	4.3 (12.9)	6.4 (19.1)	8.8 (26.3)	7.0 (20.9)	9.5 (28.4)

Down-Flow Model:	MC_-021D*-DC-DF	MC_-028D*-DC-DF	MC_-035D*-DC-DF	MC_-042D*-DC-DF	MC_-053D*-DC-DF
Cabinet Size:	A-Cabinet			B-Cabinet	

DOWN-FLOW

Airflow Rate	CFM (CMH)	3,000 (5,097)	4,000 (6,796)	5,000 (8,495)	6,000 (10,194)	7,500 (12,743)
Net Cooling Capacity MBH (kW)						
75°F DB / 62.5°F WB, 55.1°F DP, (23.9°C DB / 16.9°C WB) 50% RH						
Total	MBH (kW)	83.6 (24.5)	102.2 (30.0)	118.7 (34.8)	154.1 (45.2)	178.7 (52.4)
Sensible	MBH (kW)	69.0 (20.2)	87.0 (25.5)	103.7 (30.4)	130.7 (38.3)	155.7 (45.6)
Flow Rate	GPM (l/m)	17.0 (64.4)	20.9 (79.1)	24.4 (92.4)	31.5 (119.2)	36.7 (138.9)
Coil Fluid PD	FT WG (kPa)	6.5 (19.4)	9.7 (29.0)	8.9 (26.6)	10.5 (31.4)	10.4 (31.1)
72°F DB / 60°F WB, 52°F DP, (22.2°C DB / 15.6°C WB) 50% RH						
Total	MBH (kW)	67.0 (19.6)	82.4 (24.1)	96.3 (28.2)	124.2 (36.4)	145.0 (42.5)
Sensible	MBH (kW)	62.1 (18.2)	78.8 (23.1)	94.4 (27.7)	118.3 (34.7)	141.6 (41.5)
Flow Rate	GPM (l/m)	13.7 (51.9)	16.9 (64.0)	19.9 (75.3)	25.5 (96.5)	29.9 (113.2)
Coil Fluid PD	FT WG (kPa)	4.3 (12.9)	6.4 (19.1)	8.8 (26.3)	7.0 (20.9)	9.5 (28.4)

Nominal Size	63kW (18.0T)	70kW (20.0T)	88kW (25.0T)	97kW (27.5T)	105kW (30.0T)
Up-Flow Model:	MC_-063D*-DC-UF	MC_-070D*-DC-UF	MC_-088D*-DC-UF	MC_-097D*-DC-UF	MC_-105D*-DC-UF
Cabinet Size:	C-Cabinet		D-Cabinet	E-Cabinet	

UP-FLOW

Airflow Rate	CFM (CMH)	9,000 (15,291)	10,000 (16,990)	12,500 (21,238)	13,750 (23,361)	15,000 (25,485)
Net Cooling Capacity MBH (kW)						
75°F DB / 62.5°F WB, 55.1°F DP, (23.9°C DB / 16.9°C WB) 50% RH						
Total	MBH (kW)	213.0 (62.4)	227.6 (66.7)	266.6 (78.1)	259.0 (75.9)	272.8 (79.9)
Sensible	MBH (kW)	184.6 (54.1)	200.0 (58.6)	241.5 (70.8)	250.5 (73.4)	267.5 (78.4)
Flow Rate	GPM (l/m)	44.1 (166.9)	47.3 (179.0)	55.6 (210.5)	54.1 (204.8)	57.2 (216.5)
Coil Fluid PD	FT WG (kPa)	15.5 (46.3)	17.7 (52.9)	9.4 (28.1)	4.5 (13.5)	5.0 (14.9)
72°F DB / 60°F WB, 52°F DP, (22.2°C DB / 15.6°C WB) 50% RH						
Total	MBH (kW)	172.7 (50.6)	185.1 (54.2)	217.6 (63.8)	213.1 (62.5)	225.2 (66.0)
Sensible	MBH (kW)	167.9 (49.2)	182.4 (53.5)	217.6 (63.8)	213.1 (62.5)	225.2 (66.0)
Flow Rate	GPM (l/m)	36.0 (136.3)	38.7 (146.5)	45.7 (173.0)	44.8 (169.6)	47.5 (179.8)
Coil Fluid PD	FT WG (kPa)	10.6 (31.7)	12.2 (36.5)	10.2 (30.5)	6.6 (19.7)	7.4 (22.1)

Down-Flow Model:	MC_-063D*-DC-DF	MC_-070D*-DC-DF	MC_-088D*-DC-DF	MC_-097D*-DC-DF	MC_-105D*-DC-DF
Cabinet Size:	C-Cabinet		D-Cabinet	E-Cabinet	

DOWN-FLOW

Airflow Rate	CFM (CMH)	9,000 (15,291)	10,000 (16,990)	12,500 (21,238)	13,750 (23,361)	15,000 (25,485)
Net Cooling Capacity MBH (kW)						
75°F DB / 62.5°F WB, 55.1°F DP, (23.9°C DB / 16.9°C WB) 50% RH						
Total	MBH (kW)	214.4 (62.8)	229.2 (67.2)	268.6 (78.7)	261.1 (76.5)	275.2 (80.7)
Sensible	MBH (kW)	186.0 (54.5)	201.6 (59.1)	243.5 (71.4)	252.7 (74.1)	269.9 (79.1)
Flow Rate	GPM (l/m)	44.1 (166.9)	47.3 (179.0)	55.6 (210.5)	54.1 (204.8)	57.2 (216.5)
Coil Fluid PD	FT WG (kPa)	15.5 (46.3)	17.7 (52.9)	9.4 (28.1)	4.5 (13.5)	5 (14.9)
72°F DB / 60°F WB, 52°F DP, (22.2°C DB / 15.6°C WB) 50% RH						
Total	MBH (kW)	174.2 (51.1)	186.7 (54.7)	219.6 (64.4)	215.3 (63.1)	227.6 (66.7)
Sensible	MBH (kW)	169.3 (49.6)	183.9 (53.9)	219.6 (64.4)	215.3 (63.1)	227.6 (66.7)
Flow Rate	GPM (l/m)	36.0 (136.3)	38.7 (146.5)	45.7 (173.0)	44.8 (169.6)	47.5 (179.8)
Coil Fluid PD	FT WG (kPa)	10.6 (31.7)	12.2 (36.5)	10.2 (30.5)	6.6 (19.7)	7.4 (22.1)

Free-Cooling Coil (DX - Water Cooled, 0% Glycol) 45°F (7.2°C) EWT Cooling Capacities (21-105kW, 6-30 Tons)

Nominal Size	21kW (6.0T)	28kW (8.0T)	35kW (10.0T)	42kW (12.0T)	53kW (15.0T)
Up-Flow Model:	MCW-021D*-FE-UF	MCW-028D*-FE-UF	MCW-035D*-FE-UF	MCW-042D*-FE-UF	MCW-053D*-FE-UF
Cabinet Size:	A-Cabinet			B-Cabinet	

UP-FLOW	Airflow Rate	CFM (CMH)	3,000 (5,097)	4,000 (6,796)	5,000 (8,495)	6,000 (10,194)	7,500 (12,743)	
	Net Cooling Capacity MBH (kW)							
	75°F DB / 62.5°F WB, 55.1°F DP, (23.9°C DB / 16.9°C WB) 50% RH							
	Total	MBH (kW)	85.2 (25.0)	103.6 (30.4)	120.9 (35.4)	157.1 (46.0)	180.4 (52.9)	
	Sensible	MBH (kW)	69.3 (20.3)	87.0 (25.5)	103.5 (30.3)	130.9 (38.4)	154.6 (45.3)	
	LWT w/ 45°F EWT	°F (°C)	53.2 (11.8)	53.2 (11.8)	53.0 (11.7)	52.8 (11.6)	52.8 (11.6)	
	Flow Rate	GPM (l/m)	21.3 (80.6)	26.1 (98.8)	31.6 (119.6)	41.7 (157.9)	48.0 (181.7)	
	Coil Fluid PD	FT WG (kPa)	7.6 (22.7)	6.5 (19.4)	9.4 (28.1)	7.7 (23.0)	10.0 (29.9)	
	72°F DB / 60°F WB, 52°F DP, (22.2°C DB / 15.6°C WB) 50% RH							
	Total	MBH (kW)	72.4 (21.2)	88.4 (25.9)	103.4 (30.3)	133.8 (39.2)	154.3 (45.2)	
Sensible	MBH (kW)	64.1 (18.8)	80.7 (23.7)	96.3 (28.2)	121.3 (35.5)	143.8 (42.1)		
LWT w/ 45°F EWT	°F (°C)	52.0 (11.1)	52.0 (11.1)	51.9 (11.1)	51.7 (10.9)	51.7 (10.9)		
Flow Rate	GPM (l/m)	21.3 (80.6)	26.1 (98.8)	31.6 (119.6)	41.7 (157.9)	48.0 (181.7)		
Coil Fluid PD	FT WG (kPa)	7.6 (22.7)	6.5 (19.4)	9.4 (28.1)	7.7 (23.0)	10.0 (29.9)		

Down-Flow Model:	MCW-021D*-FE-DF	MCW-028D*-FE-DF	MCW-035D*-FE-DF	MCW-042D*-FE-DF	MCW-053D*-FE-DF
Cabinet Size:	A-Cabinet			B-Cabinet	

DOWN-FLOW	Airflow Rate	CFM (CMH)	3,000 (5,097)	5,000 (8,495)	5,000 (8,495)	6,000 (10,194)	7,500 (12,743)	
	Net Cooling Capacity MBH (kW)							
	75°F DB / 62.5°F WB, 55.1°F DP, (23.9°C DB / 16.9°C WB) 50% RH							
	Total	MBH (kW)	85.7 (25.1)	104.2 (30.5)	121.8 (35.7)	158.0 (46.3)	181.5 (53.2)	
	Sensible	MBH (kW)	69.8 (20.5)	87.6 (25.7)	104.4 (30.6)	131.9 (38.7)	155.8 (45.7)	
	LWT w/ 45°F EWT	°F (°C)	53.2 (11.8)	53.2 (11.8)	53.0 (11.7)	52.8 (11.6)	52.8 (11.6)	
	Flow Rate	GPM (l/m)	21.3 (80.6)	26.1 (98.8)	31.6 (119.6)	41.7 (157.9)	48.0 (181.7)	
	Coil Fluid PD	FT WG (kPa)	7.6 (22.7)	6.5 (19.4)	9.4 (28.1)	7.7 (23.0)	10.0 (29.9)	
	72°F DB / 60°F WB, 52°F DP, (22.2°C DB / 15.6°C WB) 50% RH							
	Total	MBH (kW)	72.9 (21.4)	89.1 (26.1)	104.2 (30.5)	134.8 (39.5)	155.4 (45.5)	
Sensible	MBH (kW)	64.6 (18.9)	81.3 (23.8)	97.1 (28.5)	122.3 (35.8)	145.0 (42.5)		
LWT w/ 45°F EWT	°F (°C)	52.0 (11.1)	52.0 (11.1)	51.9 (11.1)	51.7 (10.9)	51.7 (10.9)		
Flow Rate	GPM (l/m)	21.3 (80.6)	26.1 (98.8)	31.6 (119.6)	41.7 (157.9)	48.0 (181.7)		
Coil Fluid PD	FT WG (kPa)	7.6 (22.7)	6.5 (19.4)	9.4 (28.1)	7.7 (23.0)	10.0 (29.9)		

Nominal Size	63kW (18.0T)	70kW (20.0T)	88kW (25.0T)	97kW (27.5T)	105kW (30.0T)
Up-Flow Model:	MCW-063D*-FE-UF	MCW-070D*-FE-UF	MCW-088D*-FE-UF	MCW-097D*-FE-UF	MCW-105D*-FE-UF
Cabinet Size:	C-Cabinet		D-Cabinet	E-Cabinet	

UP-FLOW	Airflow Rate	CFM (CMH)	9,000 (15,291)	10,000 (16,990)	12,500 (21,238)	13,750 (23,361)	15,000 (25,485)	
	Net Cooling Capacity MBH (kW)							
	75°F DB / 62.5°F WB, 55.1°F DP, (23.9°C DB / 16.9°C WB) 50% RH							
	Total	MBH (kW)	208.4 (61.1)	226.7 (66.4)	257.3 (75.4)	289.2 (84.8)	310.2 (90.9)	
	Sensible	MBH (kW)	180.8 (53.0)	196.8 (57.7)	232.9 (68.3)	258.4 (75.7)	276.9 (81.2)	
	LWT w/ 45°F EWT	°F (°C)	52.3 (11.3)	51.9 (11.1)	52.0 (11.1)	51.9 (11.1)	51.5 (10.8)	
	Flow Rate	GPM (l/m)	59.8 (226.4)	69.4 (262.7)	78.5 (297.2)	89.1 (337.3)	102.3 (387.2)	
	Coil Fluid PD	FT WG (kPa)	6.2 (18.5)	8.3 (24.8)	8.1 (24.2)	6.8 (20.3)	8.8 (26.3)	
	72°F DB / 60°F WB, 52°F DP, (22.2°C DB / 15.6°C WB) 50% RH							
	Total	MBH (kW)	178.3 (52.3)	193.8 (56.8)	221.4 (64.9)	248.3 (72.8)	265.9 (77.9)	
Sensible	MBH (kW)	168.3 (49.3)	183.2 (53.7)	217.8 (63.8)	241.3 (70.7)	258.5 (75.8)		
LWT w/ 45°F EWT	°F (°C)	51.3 (10.7)	51.0 (10.6)	51.1 (10.6)	51.0 (10.6)	50.6 (10.3)		
Flow Rate	GPM (l/m)	59.8 (226.4)	69.4 (262.7)	78.5 (297.2)	89.1 (337.3)	102.3 (387.2)		
Coil Fluid PD	FT WG (kPa)	6.2 (18.5)	8.3 (24.8)	8.1 (24.2)	6.8 (20.3)	8.8 (26.3)		

Down-Flow Model:	MCW-063D*-FE-DF	MCW-070D*-FE-DF	MCW-088D*-FE-DF	MCW-097D*-FE-DF	MCW-105D*-FE-DF
Cabinet Size:	C-Cabinet		D-Cabinet	E-Cabinet	

DOWN-FLOW	Airflow Rate	CFM (CMH)	9,000 (15,291)	10,000 (16,990)	12,500 (21,238)	13,750 (23,361)	15,000 (25,485)	
	Net Cooling Capacity MBH (kW)							
	75°F DB / 62.5°F WB, 55.1°F DP, (23.9°C DB / 16.9°C WB) 50% RH							
	Total	MBH (kW)	209.8 (61.5)	228.3 (66.9)	259.3 (76.0)	291.4 (85.4)	312.6 (91.6)	
	Sensible	MBH (kW)	182.2 (53.4)	198.4 (58.1)	234.9 (68.8)	260.6 (76.4)	279.3 (81.9)	
	LWT w/ 45°F EWT	°F (°C)	52.3 (11.3)	51.9 (11.1)	52.0 (11.1)	51.9 (11.1)	51.5 (10.8)	
	Flow Rate	GPM (l/m)	59.8 (226.4)	69.4 (262.7)	78.5 (297.2)	89.1 (337.3)	102.3 (387.2)	
	Coil Fluid PD	FT WG (kPa)	6.2 (18.5)	8.3 (24.8)	8.1 (24.2)	6.8 (20.3)	8.8 (26.3)	
	72°F DB / 60°F WB, 52°F DP, (22.2°C DB / 15.6°C WB) 50% RH							
	Total	MBH (kW)	179.7 (52.7)	195.4 (57.3)	223.4 (65.5)	250.5 (73.4)	268.3 (78.6)	
Sensible	MBH (kW)	169.7 (49.7)	184.7 (54.1)	219.8 (64.4)	243.5 (71.4)	260.9 (76.5)		
LWT w/ 45°F EWT	°F (°C)	51.3 (10.7)	51.0 (10.6)	51.1 (10.6)	51.0 (10.6)	50.6 (10.3)		
Flow Rate	GPM (l/m)	59.8 (226.4)	69.4 (262.7)	78.5 (297.2)	89.1 (337.3)	102.3 (387.2)		
Coil Fluid PD	FT WG (kPa)	6.2 (18.5)	8.3 (24.8)	8.1 (24.2)	6.8 (20.3)	8.8 (26.3)		

Free-Cooling Coil (DX - Glycol Cooled, 40% EG) 45°F (7.2°C) EGT Cooling Capacities (21-105kW, 6-30 Tons)

Nominal Size	21kW (6.0T)	28kW (8.0T)	35kW (10.0T)	42kW (12.0T)	53kW (15.0T)
Up-Flow Model:	MCG-021D*-FE-UF	MCG-028D*-FE-UF	MCG-035D*-FE-UF	MCG-042D*-FE-UF	MCG-053D*-FE-UF
Cabinet Size:	A-Cabinet			B-Cabinet	

UP-FLOW

Airflow Rate	CFM (CMH)	3,000 (5,097)	4,000 (6,796)	5,000 (8,495)	6,000 (10,194)	7,500 (12,743)
Net Cooling Capacity MBH (kW)						
75°F DB / 62.5°F WB, 55.1°F DP, (23.9°C DB / 16.9°C WB) 50% RH						
Total	MBH (kW)	56.5 (16.6)	73.2 (21.5)	89.3 (26.2)	110.2 (32.3)	130.9 (38.4)
Sensible	MBH (kW)	56.5 (16.6)	73.2 (21.5)	89.3 (26.2)	110.2 (32.3)	130.9 (38.4)
LGT w/ 45°F EGT	°F (°C)	50.7 (10.4)	51.1 (10.6)	51.2 (10.7)	50.8 (10.4)	51.0 (10.6)
Flow Rate	GPM (l/m)	23.0 (87.1)	28.3 (107.1)	34.1 (129.1)	45.1 (170.7)	51.8 (196.1)
Coil Fluid PD	FT WG (kPa)	9.4 (28.1)	8.5 (25.4)	12.1 (36.2)	9.9 (29.6)	8.1 (24.2)
72°F DB / 60°F WB, 52°F DP, (22.2°C DB / 15.6°C WB) 50% RH						
Total	MBH (kW)	50.3 (14.7)	64.5 (18.9)	78.5 (23.0)	97.0 (28.4)	116.7 (34.2)
Sensible	MBH (kW)	50.3 (14.7)	64.5 (18.9)	78.5 (23.0)	97.0 (28.4)	116.7 (34.2)
LGT w/ 45°F EGT	°F (°C)	50.1 (10.1)	50.4 (10.2)	50.5 (10.3)	50.1 (10.1)	50.4 (10.2)
Flow Rate	GPM (l/m)	23.0 (87.1)	28.3 (107.1)	34.1 (129.1)	45.1 (170.7)	51.8 (196.1)
Coil Fluid PD	FT WG (kPa)	9.4 (28.1)	8.5 (25.4)	12.1 (36.2)	9.9 (29.6)	8.1 (24.2)

Down-Flow Model:	MCG-021D*-FE-DF	MCG-028D*-FE-DF	MCG-035D*-FE-DF	MCG-042D*-FE-DF	MCG-053D*-FE-DF
Cabinet Size:	A-Cabinet			B-Cabinet	

DOWN-FLOW

Airflow Rate	CFM (CMH)	3,000 (5,097)	4,000 (6,796)	5,000 (8,495)	6,000 (10,194)	7,500 (12,743)
Net Cooling Capacity MBH (kW)						
75°F DB / 62.5°F WB, 55.1°F DP, (23.9°C DB / 16.9°C WB) 50% RH						
Total	MBH (kW)	56.9 (16.7)	73.9 (21.7)	90.0 (26.4)	111.2 (32.6)	132.1 (38.7)
Sensible	MBH (kW)	56.9 (16.7)	73.9 (21.7)	90.0 (26.4)	111.2 (32.6)	132.1 (38.7)
LGT w/ 45°F EGT	°F (°C)	50.7 (10.4)	51.1 (10.6)	51.2 (10.7)	50.8 (10.4)	51.0 (10.6)
Flow Rate	GPM (l/m)	23.0 (87.1)	28.3 (107.1)	34.1 (129.1)	45.1 (170.7)	51.8 (196.1)
Coil Fluid PD	FT WG (kPa)	9.4 (28.1)	8.5 (25.4)	12.1 (36.2)	9.9 (29.6)	8.1 (24.2)
72°F DB / 60°F WB, 52°F DP, (22.2°C DB / 15.6°C WB) 50% RH						
Total	MBH (kW)	50.7 (14.9)	65.1 (19.1)	79.3 (23.2)	97.9 (28.7)	117.9 (34.6)
Sensible	MBH (kW)	50.7 (14.9)	65.1 (19.1)	79.3 (23.2)	97.9 (28.7)	117.9 (34.6)
LGT w/ 45°F EGT	°F (°C)	50.1 (10.1)	50.4 (10.2)	50.5 (10.3)	50.1 (10.1)	50.4 (10.2)
Flow Rate	GPM (l/m)	23.0 (87.1)	28.3 (107.1)	34.1 (129.1)	45.1 (170.7)	51.8 (196.1)
Coil Fluid PD	FT WG (kPa)	9.4 (28.1)	8.5 (25.4)	12.1 (36.2)	9.9 (29.6)	8.1 (24.2)

Nominal Size	63kW (18.0T)	70kW (20.0T)	88kW (25.0T)	97kW (27.5T)	105kW (30.0T)
Up-Flow Model:	MCG-063D*-FE-UF	MCG-070D*-FE-UF	MCG-088D*-FE-UF	MCG-097D*-FE-UF	MCG-105D*-FE-UF
Cabinet Size:	C-Cabinet		D-Cabinet	E-Cabinet	

UP-FLOW

Airflow Rate	CFM (CMH)	9,000 (15,291)	10,000 (16,990)	12,500 (21,238)	13,750 (23,361)	15,000 (25,485)
Net Cooling Capacity MBH (kW)						
75°F DB / 62.5°F WB, 55.1°F DP, (23.9°C DB / 16.9°C WB) 50% RH						
Total	MBH (kW)	145.3 (42.6)	164.7 (48.3)	187.7 (55.0)	219.5 (64.3)	242.7 (71.1)
Sensible	MBH (kW)	145.3 (42.6)	164.7 (48.3)	187.7 (55.0)	219.5 (64.3)	242.7 (71.1)
LGT w/ 45°F EGT	°F (°C)	50.4 (10.2)	50.3 (10.2)	50.5 (10.3)	50.6 (10.3)	50.4 (10.2)
Flow Rate	GPM (l/m)	65.2 (246.8)	75.1 (284.3)	84.2 (318.7)	96.0 (363.4)	110.6 (418.7)
Coil Fluid PD	FT WG (kPa)	8.2 (24.5)	10.8 (32.3)	10.1 (30.2)	8.8 (26.3)	11.6 (34.7)
72°F DB / 60°F WB, 52°F DP, (22.2°C DB / 15.6°C WB) 50% RH						
Total	MBH (kW)	130.3 (38.2)	147.0 (43.1)	168.6 (49.4)	196.1 (57.5)	215.7 (63.2)
Sensible	MBH (kW)	130.3 (38.2)	147.0 (43.1)	168.6 (49.4)	196.1 (57.5)	215.7 (63.2)
LGT w/ 45°F EGT	°F (°C)	49.9 (9.9)	49.8 (9.9)	49.9 (9.9)	50.0 (10.0)	49.8 (9.9)
Flow Rate	GPM (l/m)	65.2 (246.8)	75.1 (284.3)	84.2 (318.7)	96.0 (363.4)	110.6 (418.7)
Coil Fluid PD	FT WG (kPa)	8.2 (24.5)	10.8 (32.3)	10.1 (30.2)	8.8 (26.3)	11.6 (34.7)

Down-Flow Model:	MCG-063D*-FE-DF	MCG-070D*-FE-DF	MCG-088D*-FE-DF	MCG-097D*-FE-DF	MCG-105D*-FE-DF
Cabinet Size:	C-Cabinet		D-Cabinet	E-Cabinet	

DOWN-FLOW

Airflow Rate	CFM (CMH)	9,000 (15,291)	10,000 (16,990)	12,500 (21,238)	13,750 (23,361)	15,000 (25,485)
Net Cooling Capacity MBH (kW)						
75°F DB / 62.5°F WB, 55.1°F DP, (23.9°C DB / 16.9°C WB) 50% RH						
Total	MBH (kW)	146.8 (43.0)	166.3 (48.7)	189.7 (55.6)	221.7 (65.0)	245.1 (71.8)
Sensible	MBH (kW)	146.8 (43.0)	166.3 (48.7)	189.7 (55.6)	221.7 (65.0)	245.1 (71.8)
LGT w/ 45°F EGT	°F (°C)	50.4 (10.2)	50.3 (10.2)	50.5 (10.3)	50.6 (10.3)	50.4 (10.2)
Flow Rate	GPM (l/m)	65.2 (246.8)	75.1 (284.3)	84.2 (318.7)	96.0 (363.4)	110.6 (418.7)
Coil Fluid PD	FT WG (kPa)	8.2 (24.5)	10.8 (32.3)	10.1 (30.2)	8.8 (26.3)	11.6 (34.7)
72°F DB / 60°F WB, 52°F DP, (22.2°C DB / 15.6°C WB) 50% RH						
Total	MBH (kW)	131.7 (38.6)	148.5 (43.5)	170.5 (50.0)	198.2 (58.1)	218.1 (63.9)
Sensible	MBH (kW)	131.7 (38.6)	148.5 (43.5)	170.5 (50.0)	198.2 (58.1)	218.1 (63.9)
LGT w/ 45°F EGT	°F (°C)	49.9 (9.9)	49.8 (9.9)	49.9 (9.9)	50.0 (10.0)	49.8 (9.9)
Flow Rate	GPM (l/m)	65.2 (246.8)	75.1 (284.3)	84.2 (318.7)	96.0 (363.4)	110.6 (418.7)
Coil Fluid PD	FT WG (kPa)	8.2 (24.5)	10.8 (32.3)	10.1 (30.2)	8.8 (26.3)	11.6 (34.7)

Cooling Capacity Data

Physical Data - MC2-DX (21-53kW, 6-15 Tons)

Physical Data - DX Systems (21-53kW, 6-15 Tons)

Nominal Size		21kW (6.0T)	28kW (8.0T)	35kW (10.0T)	42kW (12.0T)	53kW (15.0T)
MC2-DX Model Size		MC_-021D	MC_-028D	MC_-035D	MC_-042D	MC_-053D
Reheat / Heat - Capacity does not include fan motor heat, (Optional)						
Electric Reheat / Heat - (Optional)						
Capacity - Std Option KW	MBH (kW)	51.28 (15.03)	51.28 (15.03)	51.28 (15.03)	51.28 (15.03)	68.38 (20.04)
Stages Std / (Opt.)	NO / TXT	2 / (SCR)	2 / (SCR)	2 / (SCR)	2 / (SCR)	2 / (SCR)
Capacity - Optional KW	MBH (kW)	34.19 (10.02)	34.19 (10.02)	34.19 (10.02)	34.19 (10.02)	51.28 (15.03)
Stages Std / (Opt.)	NO / TXT	2 / (SCR)	2 / (SCR)	2 / (SCR)	2 / (SCR)	2 / (SCR)
Hot Gas Reheat - (Optional, Not Available with Free-Cooling or Dual-Cool Systems)						
Capacity	MBH (kW)	65.2 (19.1)	87 (25.5)	108.7 (31.9)	130.4 (38.2)	163.1 (47.8)
HGRH Coil Rows / Face Area	NO / FT2 (m2)	1 / 13.75 (1.28)	1 / 13.75 (1.28)	1 / 13.75 (1.28)	1 / 20.00 (1.86)	1 / 20.00 (1.86)
Control Valve	TXT	3-Way Diverting (2-POS, ON/OFF) - Factory Installed				
Humidification - Electrode Steam Canister Humidifier with Adjustable Output - (Optional)						
Steam Canister	lb/hr (kg/hr)	15 (6.8)	15 (6.8)	15 (6.8)	15 (6.8)	15 (6.8)
Power Input	kW	5.1	5.1	5.1	5.1	5.1
Evaporator Fan / Motor - Direct-Drive, Backward-Inclined EC Plug Fan Impeller (Variable Speed Adjustable for Balancing)						
Airflow Rate	CFM (CMH)	3,000 (5,097)	4,000 (6,796)	5,000 (8,495)	6,000 (10,194)	7,500 (12,743)
Blower Motor / (Qty.)	kW (HP) / (NO)	4.5 (6.03) / (One)	4.5 (6.03) / (One)	4.5 (6.03) / (One)	4.5 (6.03) / (Two)	4.5 (6.03) / (Two)
E.S.P. (UP-FLOW)	IN WG	0.50	0.50	0.50	0.50	0.50
E.S.P. (DOWN-FLOW)	IN WG	0.30	0.30	0.30	0.30	0.30
Evaporator Coil - Aluminum Fin, Copper Tube						
DX Coil Rows / Face Area	NO / FT2 (m2)	3 / 13.32 (1.24)	3 / 13.32 (1.24)	3 / 13.32 (1.24)	3 / 19.57 (1.82)	3 / 19.57 (1.82)
FE/DC Coil Rows / Face Area	NO / FT2 (m2)	3 / 13.32 (1.24)	3 / 13.32 (1.24)	3 / 13.32 (1.24)	3 / 19.57 (1.82)	3 / 19.57 (1.82)
Face Velocity (Std Airflow)	FPM (m/s)	225 (1.14)	300 (1.52)	375 (1.91)	307 (1.56)	383 (1.95)
Filters - 4 in Depth, Pleated Disposable, Merv-8 Efficient						
Nom. Size (Qty.) ... MC_-UF	IN (NO)	16x24 (2) & 20x24 (2)	16x24 (2) & 20x24 (2)	16x24 (2) & 20x24 (2)	20x20 (1), 20x25 (2), 16x20 (1) & 16x25 (2)	20x20 (1), 20x25 (2), 16x20 (1) & 16x25 (2)
Nom. Size (Qty.) ... MC_-UR	IN (NO)	20x24 (2) & 24x24 (2)	20x24 (2) & 24x24 (2)	20x24 (2) & 24x24 (2)	20x24 (3), 20x20 (1) & 24x24 (2)	20x24 (3), 20x20 (1) & 24x24 (2)
Nom. Size (Qty.) ... MC_-DF	IN (NO)	16x25 (4)	16x25 (4)	16x25 (4)	16x20 (2) & 16x25 (4)	16x20 (2) & 16x25 (4)
Compressor - High Efficiency, Fixed Speed Scroll Standard						
Type (Qty.)	TXT (NO)	Scroll (Two)	Scroll (Two)	Scroll (Two)	Scroll (Two)	Scroll (Two)
2-Speed or Digital Scroll	TXT	2-Spd or Digital Opt	2-Spd or Digital Opt	2-Spd or Digital Opt	2-Spd or Digital Opt	2-Spd or Digital Opt
Connection Sizes						
Cond. Drain w/ Pump	OD IN	1/2	1/2	1/2	1/2	1/2
Cond. Drain w/o Pump	PVC FPT IN	3/4	3/4	3/4	1	1
Humidifier Inlet	OD IN	1/4	1/4	1/4	1/4	1/4
DX Refrig & W/G Condenser	TXT	See Page for Table on Page 18 for Split DX Refrigerant & Water/Glycol Condenser Piping Connections				
Dual Cool Chilled Water IN/OUT	OD IN	1-3/8	1-3/8	1-3/8	1-5/8	1-5/8
Dimensions - (Overall Nominal, For more information see detailed dimensional drawing section)						
MC_-UF (w/o Plenum, HxWxL)	IN (mm)	76x74x34 (1930.4x1879.6x863.6)	76x74x34 (1930.4x1879.6x863.6)	76x74x34 (1930.4x1879.6x863.6)	76x94x34 (1930.4x2387.6x863.6)	76x94x34 (1930.4x2387.6x863.6)
MC_-UF (w/ Plenum, HxWxL)	IN (mm)	94.5x74x34 (2400.3x1879.6x863.6)	94.5x74x34 (2400.3x1879.6x863.6)	94.5x74x34 (2400.3x1879.6x863.6)	94.5x94x34 (2400.3x2387.6x863.6)	94.5x94x34 (2400.3x2387.6x863.6)
MC_-DF (HxWxL)	IN (mm)	84.5x74x34 (2146.3x1879.6x863.6)	84.5x74x34 (2146.3x1879.6x863.6)	84.5x74x34 (2146.3x1879.6x863.6)	84.5x94x34 (2146.3x2387.6x863.6)	84.5x94x34 (2146.3x2387.6x863.6)
Weight - (Approx. - Typical Unit w/ Steam Humid, Electric Reheat & Condensate Pump)						
MCE-UF	LBS (kg)	1350 (612)	1360 (617)	1370 (621)	1850 (839)	1850 (839)
MCE-DC-UF, Dual-Cool	LBS (kg)	1500 (680)	1510 (685)	1520 (689)	2050 (930)	2050 (930)
MCE-DF	LBS (kg)	1400 (635)	1410 (639)	1420 (644)	1925 (873)	1925 (873)
MCE-DC-DF, Dual-Cool	LBS (kg)	1550 (703)	1560 (707)	1570 (712)	2125 (964)	2125 (964)
MCW or MCG-UF	LBS (kg)	1500 (680)	1510 (685)	1520 (689)	2000 (907)	2000 (907)
MCW or MCG-FE-UF, Free-Cool	LBS (kg)	1650 (748)	1660 (753)	1670 (757)	2200 (998)	2200 (998)
MCW or MCG-DF	LBS (kg)	1550 (703)	1560 (707)	1570 (712)	2075 (941)	2075 (941)
MCW or MCG-FE-DF, Free-Cool	LBS (kg)	1700 (771)	1710 (776)	1720 (780)	2275 (1032)	2275 (1032)
Plenum Box	LBS (kg)	130 (59)	130 (59)	130 (59)	170 (77)	170 (77)
XP2-* Remote Condenser	LBS (kg)	1020 (463)	1020 (463)	1020 (463)	1370 (621)	1370 (621)
Shipping Pallet (add to above)	LBS (kg)	125 (57)	125 (57)	125 (57)	150 (68)	150 (68)

ALL SYSTEMS

Physical Data - MC2-DX (63-105kW, 18-30 Tons)

Physical Data - DX Systems (63-105kW, 18-30 Tons)

Nominal Size		63kW (18.0T)	70kW (20.0T)	88kW (25.0T)	97kW (27.5T)	105kW (30.0T)
MC2-DX Model Size		MC_-063D	MC_-070D	MC_-088D	MC_-097D	MC_-105D
Reheat / Heat - Capacity does not include fan motor heat, (Optional)						
Electric Reheat / Heat - (Optional)						
Capacity	MBH (kW)	68.38 (20.04)	85.47 (25.05)	85.47 (25.05)	102.57 (30.6)	102.57 (30.6)
Stages Std / (Opt.)	NO / TXT	2 / (SCR)	2 / (SCR)	2 / (SCR)	2 / (SCR)	2 / (SCR)
Capacity	MBH (kW)	51.28 (15.03)	51.28 (15.03)	68.38 (20.04)	68.38 (20.04)	68.38 (20.04)
Stages Std / (Opt.)	NO / TXT	2 / (SCR)	2 / (SCR)	2 / (SCR)	2 / (SCR)	2 / (SCR)
Hot Gas Reheat - (Optional, Not Available with Free-Cooling or Dual-Cool Systems)						
Capacity	MBH (kW)	195.7 (57.4)	217.4 (63.7)	271.8 (79.7)	298.9 (87.6)	326.1 (95.6)
HGRH Coil Rows / Face Area	NO / FT2 (m2)	1 / 22.5 (2.09)	1 / 22.5 (2.09)	1 / 26.02 (2.42)	1 / 28.36 (2.63)	1 / 28.36 (2.63)
Control Valve	TXT	3-Way Diverting (2-POS, ON/OFF) - Factory Installed				
Humidification - Electrode Steam Canister Humidifier with Adjustable Output - (Optional)						
Steam Canister	lb/hr (kg/hr)	20 (9.1)	20 (9.1)	25 (11.3)	25 (11.3)	25 (11.3)
Power Input	kW	6.8	6.8	8.5	8.5	8.5
Evaporator Fan / Motor - Direct-Drive, Backward-Inclined EC Plug Fan Impeller (Variable Speed Adjustable for Balancing)						
Airflow Rate	CFM (CMH)	9,000 (15,291)	10,000 (16,990)	12,500 (21,238)	13,750 (23,361)	15,000 (25,485)
Blower Motor / (Qty.)	kW (HP) / (NO)	4.5 (6.03) / (Two)	4.5 (6.03) / (Two)	4.5 (6.03) / (Three)	4.5 (6.03) / (Three)	4.5 (6.03) / (Three)
E.S.P. (UP-FLOW)	IN WG	0.50	0.50	0.50	0.50	0.50
E.S.P. (DOWN-FLOW)	IN WG	0.30	0.30	0.30	0.30	0.30
Evaporator Coil - Aluminum Fin, Copper Tube						
DX Coil Rows / Face Area	NO / FT2 (m2)	3 / 22.07 (2.05)	3 / 22.07 (2.05)	3 / 25.82 (2.40)	3 / 28.16 (2.62)	3 / 28.16 (2.62)
FE/DC Coil Rows / Face Area	NO / FT2 (m2)	3 / 22.07 (2.05)	3 / 22.07 (2.05)	3 / 25.82 (2.40)	3 / 28.16 (2.62)	3 / 28.16 (2.62)
Face Velocity (Std Airflow)	FPM (m/s)	408 (2.07)	453 (2.30)	484 (2.46)	488 (2.48)	533 (2.71)
Filters - 4 in Depth, Pleated Disposable, Merv-8 Efficient						
Nom. Size (Qty.) ... MC_-UF	IN (NO)	20x20 (4) & 16x20 (4)	20x20 (4) & 16x20 (4)	20x24 (3), 20x20 (1) & 16x24 (3) & 16x20 (1)	20x25 (4) & 16x25 (4)	20x25 (4) & 16x25 (4)
Nom. Size (Qty.) ... MC_-UR	IN (NO)	24x24 (3) & 20x20 (3)	24x24 (3) & 20x20 (3)	24x24 (2), 20x24 (4) & 20x20 (2)	24x24 (4) & 20x24 (4)	24x24 (4) & 20x24 (4)
Nom. Size (Qty.) ... MC_-DF	IN (NO)	16x25 (6)	16x25 (6)	16x20 (4) & 16x25 (4)	16x25 (8)	16x25 (8)
Compressor - High Efficiency, Fixed Speed Scroll Standard						
Type (Qty.)	TXT (NO)	Scroll (Two)	Scroll (Two)	Scroll (Two)	Scroll (Two)	Scroll (Two)
2-Speed or Digital Scroll	TXT	2-Spd or Digital Opt	2-Spd or Digital Opt	2-Spd or Digital Opt	2-Spd or Digital Opt	2-Spd or Digital Opt
Connection Sizes						
Cond. Drain w/ Pump	OD IN	1/2	1/2	1/2	1/2	1/2
Cond. Drain w/o Pump	PVC FPT IN	1	1	1	1	1
Humidifier Inlet	OD IN	1/4	1/4	1/4	1/4	1/4
DX Refrig & W/G Condenser	TXT	See Page for Table on Page 19 for Split DX Refrigerant & Water/Glycol Condenser Piping Connections				
Dual Cool Chilled Water IN/OUT	OD IN	1-5/8	1-5/8	2-1/8	2-1/8	2-1/8
Dimensions - (Overall Nominal, For more information see detailed dimensional drawing section)						
MC_-UF (w/o Plenum, HxWxL)	IN (mm)	76x109x34 (1930.4x2768.6x863.6)	76x109x34 (1930.4x2768.6x863.6)	76x122x34 (1930.4x3098.8x863.6)	76x132x34 (1930.4x3352.8x863.6)	76x132x34 (1930.4x3352.8x863.6)
MC_-UF (w Plenum, HxWxL)	IN (mm)	94.5x109x34 (2400.3x2768.6x863.6)	94.5x109x34 (2400.3x2768.6x863.6)	94.5x122x34 (2400.3x3098.8x863.6)	94.5x132x34 (2400.3x3352.8x863.6)	94.5x132x34 (2400.3x3352.8x863.6)
MC_-DF (HxWxL)	IN (mm)	84.5x109x34 (2146.3x2768.6x863.6)	84.5x109x34 (2146.3x2768.6x863.6)	84.5x122x34 (2146.3x3098.8x863.6)	84.5x132x34 (2146.3x3352.8x863.6)	84.5x132x34 (2146.3x3352.8x863.6)
Weight - (Approx. - Typical Unit w/ Steam Humid, Electric Reheat & Condensate Pump)						
MCE-UF	LBS (kg)	1900 (862)	1900 (862)	1910 (866)	2650 (1202)	2670 (1211)
MCE-DC-UF, Dual-Cool	LBS (kg)	2150 (975)	2150 (975)	2060 (934)	2950 (1338)	2970 (1347)
MCE-DF	LBS (kg)	2000 (907)	2000 (907)	1960 (889)	2800 (1270)	2820 (1279)
MCE-DC-DF, Dual-Cool	LBS (kg)	2250 (1020)	2250 (1020)	2110 (957)	3100 (1406)	3120 (1415)
MCW or MCG-UF	LBS (kg)	2100 (952)	2100 (952)	2060 (934)	2850 (1293)	2870 (1302)
MCW or MCG-FE-UF, Free-Cool	LBS (kg)	2350 (1066)	2350 (1066)	2210 (1002)	3150 (1429)	3170 (1438)
MCW or MCG-DF	LBS (kg)	2200 (998)	2200 (998)	2110 (957)	3000 (1361)	3020 (1370)
MCW or MCG-FE-DF, Free-Cool	LBS (kg)	2450 (1111)	2450 (1111)	2260 (1025)	3300 (1497)	3320 (1506)
Plenum Box	LBS (kg)	190 (86)	190 (86)	210 (95)	225 (102)	225 (102)
XP2-* Remote Condenser	LBS (kg)	1370 (621)	1370 (621)	1415 (642)	1415 (642)	1415 (642)
Shipping Pallet (add to above)	LBS (kg)	200 (91)	200 (91)	250 (113)	300 (136)	300 (136)

ALL SYSTEMS

DX - Heat Rejection Data - MC2-DX (21-53kW, 6-15 Tons)

DX - Heat Rejection Data (21-53kW, 6-15 Tons)

DX - AIR COOLED CONDENSER DATA - 95°F AMBIENT

Nominal Size	21kW (6.0T)	28kW (8.0T)	35kW (10.0T)	42kW (12.0T)	53kW (15.0T)
DX - Air Cooled Model	MCE-021D	MCE-028D	MCE-035D	MCE-042D	MCE-053D

AIR COOLED DX

Outdoor, Remote Propeller Fan Air Cooled Condensers - (XP2 models)						
Remote Condenser Model	TXT	XPX-021D	XPX-028D	XPX-035D	XPX-042D	XPX-053D
Airflow Rate	CFM (CMH)	10,000 (16,990)	10,000 (16,990)	10,000 (16,990)	13,000 (22,087)	13,000 (22,087)
E.S.P.	IN WG	Free Discharge	Free Discharge	Free Discharge	Free Discharge	Free Discharge
Fan Motor Power Rating Each	kW (HP)	3.32 (4.45)	3.32 (4.45)	3.32 (4.45)	3.35 (4.49)	3.35 (4.49)
Fan / Motor Qty.	NO	Two	Two	Two	Two	Two
Fan Type	TXT	DD - Axial EC	DD - Axial EC	DD - Axial EC	DD - Axial EC	DD - Axial EC
Rows / Face Area	NO / FT2 (m2)	2 / 34.50 (3.21)	2 / 34.50 (3.21)	2 / 34.50 (3.21)	3 / 43.40 (4.03)	3 / 43.40 (4.03)

DX - WATER COOLED CONDENSER DATA

Nominal Size	21kW (6.0T)	28kW (8.0T)	35kW (10.0T)	42kW (12.0T)	53kW (15.0T)
DX - Water Cooled Model	MCW-021D	MCW-028D	MCW-035D	MCW-042D	MCW-053D

WATER COOLED DX

Water Cooled Condenser Data - 85°F EWT / 95°F LWT, 0% Glycol Solution (rated at 75°F DB/62.5°F WB EAT Cooling Performance)						
Total Heat of Rej.	MBH (kW)	106.6 (31.2)	130.5 (38.2)	158.2 (46.4)	208.7 (61.2)	239.8 (70.3)
Flow 85°F EWT	GPM (l/m)	21.3 (80.6)	26.1 (98.8)	31.6 (119.6)	41.7 (157.9)	48.0 (181.7)
Fluid Pressure Drop	FT WG (kPa)	15.0 (44.8)	9.4 (28.1)	12.5 (37.4)	22.7 (67.9)	21.5 (64.3)
Condenser Type	TXT	SS Brazed-Plate	SS Brazed-Plate	SS Brazed-Plate	SS Brazed-Plate	SS Brazed-Plate
Water Reg. Valve	TXT	2-Way, 580 psig Electronic 0-10Vdc - factory installed, (3-Way Valves are Optional)				
Valve Size, (Cv)	IN (NO)	1-1/4 (29.2)	1-1/4 (29.2)	1-1/4 (29.2)	1-1/2 (29.2)	1-1/2 (29.2)

DX - GLYCOL COOLED CONDENSER DATA

Nominal Size	21kW (6.0T)	28kW (8.0T)	35kW (10.0T)	42kW (12.0T)	53kW (15.0T)
DX - Glycol Cooled Model	MCG-021D	MCG-028D	MCG-035D	MCG-042D	MCG-053D

GLYCOL COOLED DX

Glycol Cooled Condenser Data - 110°F EWT / 120°F LWT, 40% Ethylene Glycol Solution (rated at 75°F DB/62.5°F WB EAT Cooling Performance)						
Total Heat of Rej.	MBH (kW)	101.5 (29.7)	124.8 (36.6)	150.3 (44.0)	198.8 (58.3)	228.1 (66.8)
Flow 110°F EGT, 40% EG	GPM (l/m)	23.0 (87.1)	28.3 (107.1)	34.1 (129.1)	45.1 (170.7)	51.8 (196.1)
Fluid Pressure Drop	FT WG (kPa)	17.5 (52.3)	11.1 (33.2)	14.5 (43.3)	26.5 (79.2)	25.0 (74.7)
Condenser Type	TXT	SS Brazed-Plate	SS Brazed-Plate	SS Brazed-Plate	SS Brazed-Plate	SS Brazed-Plate
Glycol Reg. Valve	TXT	2-Way, 580 psig Electronic 0-10Vdc - factory installed, (3-Way Valves are Optional)				
Valve Size, (Cv)	IN (NO)	1-1/4 (29.2)	1-1/4 (29.2)	1-1/4 (29.2)	1-1/2 (29.2)	1-1/2 (29.2)

Connection Data

ALL DX SYSTEMS

DX - Split Evaporators - (MCE models)						
Liquid Line	OD IN	(2) 3/8	(2) 1/2	(2) 1/2	(2) 1/2	(2) 1/2
Discharge Line	OD IN	(2) 3/4	(2) 3/4	(2) 3/4	(2) 7/8	(2) 7/8
DX - Outdoor, Axial Fan Remote Air Cooled Condensers - (XPX models)						
Liquid Line	OD IN	(2) 3/8	(2) 1/2	(2) 1/2	(2) 1/2	(2) 1/2
Discharge Line	OD IN	(2) 3/4	(2) 3/4	(2) 3/4	(2) 7/8	(2) 7/8
DX - Water / Glycol Cooled - (MCW & MCG models)						
Condenser Water/Glycol IN/OUT	OD IN	1-3/8	1-3/8	1-3/8	1-5/8	1-5/8

DX - Heat Rejection Data - MC2-DX (63-105kW, 18-30 Tons)

DX - Heat Rejection Data (63-105kW, 18-30 Tons)

DX - AIR COOLED CONDENSER DATA - 95°F AMBIENT

Nominal Size	63kW (18.0T)	70kW (20.0T)	88kW (25.0T)	97kW (27.5T)	105kW (30.0T)
DX - Air Cooled Model	MCE-063D	MCE-070D	MCE-088D	MCE-097D	MCE-105D

**AIR
COOLED
DX**

Outdoor, Remote Propeller Fan Air Cooled Condensers - (XP2 models)						
Remote Condenser Model	TXT	XP2-216D	XP2-240D	XP2-300D	XP2-330D	XP2-360D
Airflow Rate	CFM (CMH)	13,000 (22,087)	13,000 (22,087)	22,000 (37,378)	22,000 (37,378)	22,000 (37,378)
E.S.P.	IN WG	Free Discharge	Free Discharge	Free Discharge	Free Discharge	Free Discharge
Fan Motor Power Rating Each	kW (HP)	3.35 (4.49)	3.35 (4.49)	3.35 (4.49)	3.35 (4.49)	3.35 (4.49)
Blower / Motor Qty.	NO	Two	Two	Two	Two	Two
Blower Type	TXT	DD - Axial EC	DD - Axial EC	DD - Axial EC	DD - Axial EC	DD - Axial EC
Rows / Face Area	NO / FT2 (m2)	3 / 43.40 (4.03)	3 / 43.40 (4.03)	3 / 48.0 (4.46)	3 / 48.0 (4.46)	3 / 48.0 (4.46)

DX - WATER COOLED CONDENSER DATA

Nominal Size	63kW (18.0T)	70kW (20.0T)	88kW (25.0T)	97kW (27.5T)	105kW (30.0T)
DX - Water Cooled Model	MCW-063D	MCW-070D	MCW-088D	MCW-097D	MCW-105D

**WATER
COOLED
DX**

Water Cooled Condenser Data - 85°F EWT / 95°F LWT, 0% Glycol Solution (rated at 75°F DB/62.5°F WB EAT Cooling Performance)						
Total Heat of Rej.	MBH (kW)	299.2 (87.7)	346.9 (101.7)	392.4 (115.0)	445.6 (130.6)	511.7 (150.0)
Flow 85°F EWT	GPM (l/m)	59.8 (226.4)	69.4 (262.7)	78.5 (297.2)	89.1 (337.3)	102.3 (387.2)
Fluid Pressure Drop	FT WG (kPa)	11.6 (34.7)	15.5 (46.3)	21.7 (64.9)	20.4 (61.0)	26.9 (80.4)
Condenser Type	TXT	SS Brazed-Plate	SS Brazed-Plate	SS Brazed-Plate	SS Brazed-Plate	SS Brazed-Plate
Water Reg. Valve	TXT	2-Way, 580 psig Electronic 0-10Vdc - factory installed, (3-Way Valves are Optional)				
Valve Size, (Cv)	IN (NO)	1-1/2 (29.2)	2 (46.8)	2 (46.8)	2 (46.8)	2 (46.8)

DX - GLYCOL COOLED CONDENSER DATA

Nominal Size	63kW (18.0T)	70kW (20.0T)	88kW (25.0T)	97kW (27.5T)	105kW (30.0T)
DX - Glycol Cooled Model	MCG-063D	MCG-070D	MCG-088D	MCG-097D	MCG-105D

**GLYCOL
COOLED
DX**

Glycol Cooled Condenser Data - 110°F EWT / 120°F LWT, 40% Ethylene Glycol Solution (rated at 75°F DB/62.5°F WB EAT Cooling Performance)						
Total Heat of Rej.	MBH (kW)	287.3 (84.2)	331.1 (97.0)	371.1 (108.8)	423.0 (124.0)	487.5 (142.9)
Flow 110°F EGT, 40% EG	GPM (l/m)	65.2 (246.8)	75.1 (284.3)	84.2 (318.7)	96.0 (363.4)	110.6 (418.7)
Fluid Pressure Drop	FT WG (kPa)	13.7 (40.9)	18.2 (54.4)	25.0 (74.7)	23.7 (70.8)	31.4 (93.9)
Condenser Type	TXT	SS Brazed-Plate	SS Brazed-Plate	SS Brazed-Plate	SS Brazed-Plate	SS Brazed-Plate
Glycol Reg. Valve	TXT	2-Way, 580 psig Electronic 0-10Vdc - factory installed, (3-Way Valves are Optional)				
Valve Size, (Cv)	IN (NO)	1-1/2 (29.2)	2 (46.8)	2 (46.8)	2 (46.8)	2 (46.8)

Connection Data

**ALL
DX
SYSTEMS**

DX - Split Evaporators - (MCE models)						
Liquid Line	OD IN	(2) 5/8	(2) 5/8	(2) 5/8	(2) 3/4	(2) 3/4
Discharge Line	OD IN	(2) 7/8	(2) 1-1/8	(2) 1-1/8	(2) 1-1/8	(2) 1-1/8
DX - Outdoor, Axial Fan Remote Air Cooled Condensers - (XPX models)						
Liquid Line	OD IN	(2) 5/8	(2) 5/8	(2) 5/8	(2) 3/4	(2) 3/4
Discharge Line	OD IN	(2) 7/8	(2) 1-1/8	(2) 1-1/8	(2) 1-1/8	(2) 1-1/8
DX - Water / Glycol Cooled - (MCW & MCG models)						
Condenser Water/Glycol IN/OUT	OD IN	1-5/8	2-1/8	2-1/8	2-1/8	2-1/8

ELECTRICAL COMPONENT DATA - MC2-DX

Unit Size (Nom. Tons)	MC2-DX Model	Main Power Supply	Compressor (Fixed Speed)				Evap Fan Motor				Electric Reheat/Heat (Optional)		Steam Humidifier (Optional)		
			Qty.	RLA	LRA	Type	Qty.	FLA	kW (HP)	Type	KW	FLA	LB/HR (kg/hr)	FLA	KW
21Kw (6.0 Tons)	MCE,W,G-021D-3-*	208/3/60	2	13.5	88.0	Scroll	1	7.0	4.5 (6.03)	EC	15.03	41.8	15 (6.8)	14.0	5.1
	MCE,W,G-021D-4-*	460/3/60	2	6.0	44.0	Scroll	1	5.9	4.5 (6.03)	EC	15.03	18.9	15 (6.8)	6.1	5.1
28Kw (8.0 Tons)	MCE,W,G-028D-3-*	208/3/60	2	15.6	110.0	Scroll	1	7.0	4.5 (6.03)	EC	15.03	41.8	15 (6.8)	14.0	5.1
	MCE,W,G-028D-4-*	460/3/60	2	14.5	98.0	Scroll	1	5.9	4.5 (6.03)	EC	15.03	18.9	15 (6.8)	6.1	5.1
35Kw (10.0 Tons)	MCE,W,G-035D-3-*	208/3/60	2	6.3	55.0	Scroll	1	7.0	4.5 (6.03)	EC	15.03	41.8	15 (6.8)	14.0	5.1
	MCE,W,G-035D-4-*	460/3/60	2	7.8	52.0	Scroll	1	5.9	4.5 (6.03)	EC	15.03	18.9	15 (6.8)	6.1	5.1
42Kw (12.0 Tons)	MCE,W,G-042D-3-*	208/3/60	2	23.2	164.0	Scroll	2	7.0	4.5 (6.03)	EC	15.03	41.8	15 (6.8)	14.0	5.1
	MCE,W,G-042D-4-*	460/3/60	2	11.2	75.0	Scroll	2	5.9	4.5 (6.03)	EC	15.03	18.9	15 (6.8)	6.1	5.1
53Kw (15.0 Tons)	MCE,W,G-053D-3-*	208/3/60	2	25.0	164.0	Scroll	2	7.0	4.5 (6.03)	EC	20.04	55.7	15 (6.8)	14.0	5.1
	MCE,W,G-053D-4-*	460/3/60	2	12.2	100.0	Scroll	2	5.9	4.5 (6.03)	EC	20.04	25.2	15 (6.8)	6.1	5.1
63Kw (18.0 Tons)	MCE,W,G-063D-3-*	208/3/60	2	30.1	225.0	Scroll	2	7.0	4.5 (6.03)	EC	20.04	55.7	20 (9.1)	19.0	8.5
	MCE,W,G-063D-4-*	460/3/60	2	16.7	114.0	Scroll	2	5.9	4.5 (6.03)	EC	20.04	25.2	20 (9.1)	8.2	8.5
70Kw (20.0 Tons)	MCE,W,G-070D-3-*	208/3/60	2	33.3	239.0	Scroll	2	7.0	4.5 (6.03)	EC	25.05	69.6	20 (9.1)	19.0	8.5
	MCE,W,G-070D-4-*	460/3/60	2	17.9	125.0	Scroll	2	5.9	4.5 (6.03)	EC	25.05	31.5	20 (9.1)	8.2	8.5
88Kw (25.0 Tons)	MCE,W,G-088D-3-*	208/3/60	2	48.1	245.0	Scroll	3	6.5	4.5 (6.03)	EC	25.05	69.6	25 (11.3)	24.0	10.0
	MCE,W,G-088D-4-*	460/3/60	2	18.6	125.0	Scroll	3	6.1	4.5 (6.03)	EC	25.05	31.5	25 (11.3)	10.0	10.0
97Kw (27.5 Tons)	MCE,W,G-097D-3-*	208/3/60	2	51.3	300.0	Scroll	3	7.0	4.5 (6.03)	EC	30.06	83.5	25 (11.3)	24.0	10.0
	MCE,W,G-097D-4-*	460/3/60	2	23.1	150.0	Scroll	3	5.9	4.5 (6.03)	EC	30.06	37.8	25 (11.3)	10.0	10.0
105Kw (30.0 Tons)	MCE,W,G-105D-3-*	208/3/60	2	55.8	340.0	Scroll	3	7.0	4.5 (6.03)	EC	30.06	83.5	25 (11.3)	24.0	10.0
	MCE,W,G-105D-4-*	460/3/60	2	26.9	173.0	Scroll	3	5.9	4.5 (6.03)	EC	30.06	37.8	25 (11.3)	10.0	10.0

Electrical Data (MC2-DX) - Fixed Speed Scroll

21-53kW (6-15T) w/ Standard Fixed Speed Dual Scroll Compressors

MODEL	MCE, W or G-021D		MCE, W or G-028D		MCE, W or G-035D		MCE, W or G-042D		MCE, W or G-053D	
	208/3/60	460/3/60	208/3/60	460/3/60	208/3/60	460/3/60	208/3/60	460/3/60	208/3/60	460/3/60
Power Supply	208/3/60	460/3/60	208/3/60	460/3/60	208/3/60	460/3/60	208/3/60	460/3/60	208/3/60	460/3/60
Cooling Only (or Cooling with Hot Gas Reheat)										
FLA	34.1	17.8	36.0	18.6	38.3	21.4	60.4	34.2	64.0	36.2
MCA	37.4	19.3	39.6	20.2	42.2	23.4	66.2	37.0	70.3	39.2
MOP	50	25	50	25	50	30	80	45	90	50
with Standard KW Option Electric Heat (No Electric Reheat or Humidifier)										
FLA	48.7	24.8	48.7	24.8	48.7	24.8	60.4	34.2	69.6	37.0
MCA	60.9	31.0	60.9	31.0	60.9	31.0	69.6	38.3	87.0	46.2
MOP	70	35	70	35	70	35	80	45	90	50
with Standard KW Option Electric Reheat/Heat (No Humidifier)										
FLA	75.8	36.7	77.7	37.5	80.0	40.3	102.1	53.1	119.6	61.3
MCA	89.6	42.9	91.7	43.8	94.3	46.9	118.4	60.6	139.8	70.6
MOP	90	45	100	45	100	50	125	70	150	80
with Humidifier with or without Hot Gas Reheat (No Electric Reheat/Heat)										
FLA	48.1	23.9	50.0	24.7	52.3	27.5	74.4	40.3	78.0	42.3
MCA	51.4	25.4	53.6	26.3	56.2	29.5	80.2	43.1	84.3	45.3
MOP	60	30	60	30	70	35	100	50	100	50
with Standard KW Option Electric Heat (No Electric Reheat) & Humidifier										
FLA	62.7	30.9	62.7	30.9	62.7	30.9	74.4	40.3	83.6	43.1
MCA	74.9	37.1	74.9	37.1	74.9	37.1	83.6	44.4	101.0	52.3
MOP	80	40	80	40	80	40	100	50	110	60
with Standard KW Optional Electric Reheat/Heat & Humidifier										
FLA	75.8	36.7	77.7	37.5	80.0	40.3	102.1	53.1	119.6	61.3
MCA	89.6	42.9	91.7	43.8	94.3	46.9	118.4	60.6	139.8	70.6
MOP	90	45	100	45	100	50	125	70	150	80

63-105kW (18-30T) w/ Standard Fixed Speed Dual Scroll Compressors

MODEL	MCE, W or G-063D		MCE, W or G-070D		MCE, W or G-088D		MCE, W or G-097D		MCE, W or G-105D	
	208/3/60	460/3/60	208/3/60	460/3/60	208/3/60	460/3/60	208/3/60	460/3/60	208/3/60	460/3/60
Power Supply	208/3/60	460/3/60	208/3/60	460/3/60	208/3/60	460/3/60	208/3/60	460/3/60	208/3/60	460/3/60
Cooling Only (or Cooling with Hot Gas Reheat)										
FLA	74.3	45.1	80.7	47.7	115.7	55.3	123.6	63.9	132.5	71.5
MCA	81.8	49.3	89.0	52.2	127.7	60.0	136.4	69.6	146.5	78.3
MOP	110	60	110	70	175	70	175	90	200	100
with Standard KW Option Electric Heat (No Electric Reheat or Humidifier)										
FLA	74.3	45.1	83.5	47.7	115.7	55.3	123.6	63.9	132.5	71.5
MCA	87.0	49.3	104.4	54.1	127.7	62.0	136.4	69.6	146.5	78.3
MOP	110	60	110	70	175	70	175	90	200	100
with Standard KW Option Electric Reheat/Heat (No Humidifier)										
FLA	129.9	70.3	150.2	79.1	185.2	86.8	207.0	101.6	216.0	109.3
MCA	151.3	80.7	175.9	91.5	214.6	99.3	240.7	116.8	250.8	125.4
MOP	175	90	200	100	225	110	250	125	300	150
with Humidifier with or without Hot Gas Reheat (No Electric Reheat/Heat)										
FLA	93.3	53.3	99.7	55.9	139.7	65.3	147.6	73.9	156.5	81.5
MCA	100.8	57.5	108.0	60.4	151.7	70.0	160.4	79.6	170.5	88.3
MOP	125	70	125	70	175	80	200	100	225	110
with Standard KW Option Electric Heat (No Electric Reheat) & Humidifier										
FLA	93.3	53.3	102.5	55.9	139.7	65.3	147.6	73.9	156.5	81.5
MCA	106.0	57.5	123.4	62.3	151.7	72.0	160.4	79.6	170.5	88.3
MOP	125	70	125	70	175	80	200	100	225	110
with Standard KW Optional Electric Reheat/Heat & Humidifier										
FLA	129.9	70.3	150.2	79.1	185.2	86.8	207.0	101.6	216.0	109.3
MCA	151.3	80.7	175.9	91.5	214.6	99.3	240.7	116.8	250.8	125.4
MOP	175	90	200	100	225	110	250	125	300	150

Notes:

- 1) FLA = Full Load Amps; MCA = Min Circuit Amps; MOP = Max Overcurrent Protection (Max Fuse Size)
- 2) - - - - Consult local AboveAir Sales Representative for non-cataloged system power supply information.

Electrical Data (MC2-DX) - Digital Scroll Option

21-53kW (6-15T) w/ Optional Lead-Digital Dual Scroll Compressors

MODEL	MCE, W or G-021D		MCE, W or G-028D		MCE, W or G-035D		MCE, W or G-042D		MCE, W or G-053D	
	208/3/60	460/3/60	208/3/60	460/3/60	208/3/60	460/3/60	208/3/60	460/3/60	208/3/60	460/3/60
Power Supply	208/3/60	460/3/60	208/3/60	460/3/60	208/3/60	460/3/60	208/3/60	460/3/60	208/3/60	460/3/60
Cooling Only (or Cooling with Hot Gas Reheat)										
FLA	32.2	18.0	37.6	20.0	39.5	21.7	60.4	34.2	63.0	36.6
MCA	35.1	19.6	41.6	21.9	43.7	23.8	66.2	37.0	69.0	39.8
MOP	45	25	50	25	60	30	80	45	90	50
with Standard KW Option Electric Heat (No Electric Reheat or Humidifier)										
FLA	48.7	24.8	48.7	24.8	48.7	24.8	60.4	34.2	69.6	37.0
MCA	60.9	31.0	60.9	31.0	60.9	31.0	69.6	38.3	87.0	46.2
MOP	70	35	70	35	70	35	80	45	90	50
with Standard KW Option Electric Reheat/Heat (No Humidifier)										
FLA	73.9	36.9	79.3	38.9	81.2	40.6	102.1	53.1	118.7	61.8
MCA	87.3	43.2	93.7	45.5	95.9	47.3	118.4	60.6	138.6	71.2
MOP	90	45	100	50	100	50	125	70	150	80
with Humidifier with or without Hot Gas Reheat (No Electric Reheat/Heat)										
FLA	46.2	24.1	51.6	26.1	53.5	27.8	74.4	40.3	77.0	42.7
MCA	49.1	25.7	55.6	28.0	57.7	29.9	80.2	43.1	83.0	45.9
MOP	60	30	70	35	70	35	100	50	100	50
with Standard KW Option Electric Heat (No Electric Reheat) & Humidifier										
FLA	62.7	30.9	62.7	30.9	62.7	30.9	74.4	40.3	83.6	43.1
MCA	74.9	37.1	74.9	37.1	74.9	37.1	83.6	44.4	101.0	52.3
MOP	80	40	80	40	80	40	100	50	110	60
with Standard KW Optional Electric Reheat/Heat & Humidifier										
FLA	73.9	36.9	79.3	38.9	81.2	40.6	102.1	53.1	118.7	61.8
MCA	87.3	43.2	93.7	45.5	95.9	47.3	118.4	60.6	138.6	71.2
MOP	90	45	100	50	100	50	125	70	150	80

63-105kW (18-30T) w/ Optional Lead-Digital Dual Scroll Compressors

MODEL	MCE, W or G-063D		MCE, W or G-070D		MCE, W or G-088D		MCE, W or G-097D		MCE, W or G-105D	
	208/3/60	460/3/60	208/3/60	460/3/60	208/3/60	460/3/60	208/3/60	460/3/60	208/3/60	460/3/60
Power Supply	208/3/60	460/3/60	208/3/60	460/3/60	208/3/60	460/3/60	208/3/60	460/3/60	208/3/60	460/3/60
Cooling Only (or Cooling with Hot Gas Reheat)										
FLA	74.3	45.1	80.7	47.7	115.7	55.3	123.6	63.9	132.5	71.5
MCA	81.8	49.3	89.0	52.2	127.7	60.0	136.4	69.6	146.5	78.3
MOP	110	60	110	70	175	70	175	90	200	100
with Standard KW Option Electric Heat (No Electric Reheat or Humidifier)										
FLA	74.3	45.1	83.5	47.7	115.7	55.3	123.6	63.9	132.5	71.5
MCA	87.0	49.3	104.4	54.1	127.7	62.0	136.4	69.6	146.5	78.3
MOP	110	60	110	70	175	70	175	90	200	100
with Standard KW Option Electric Reheat/Heat (No Humidifier)										
FLA	129.9	70.3	150.2	79.1	185.2	86.8	207.0	101.6	216.0	109.3
MCA	151.3	80.7	175.9	91.5	214.6	99.3	240.7	116.8	250.8	125.4
MOP	175	90	200	100	225	110	250	125	300	150
with Humidifier with or without Hot Gas Reheat (No Electric Reheat/Heat)										
FLA	93.3	53.3	99.7	55.9	139.7	65.3	147.6	73.9	156.5	81.5
MCA	100.8	57.5	108.0	60.4	151.7	70.0	160.4	79.6	170.5	88.3
MOP	125	70	125	70	175	80	200	100	225	110
with Standard KW Option Electric Heat (No Electric Reheat) & Humidifier										
FLA	93.3	53.3	102.5	55.9	139.7	65.3	147.6	73.9	156.5	81.5
MCA	106.0	57.5	123.4	62.3	151.7	72.0	160.4	79.6	170.5	88.3
MOP	125	70	125	70	175	80	200	100	225	110
with Standard KW Optional Electric Reheat/Heat & Humidifier										
FLA	129.9	70.3	150.2	79.1	185.2	86.8	207.0	101.6	216.0	109.3
MCA	151.3	80.7	175.9	91.5	214.6	99.3	240.7	116.8	250.8	125.4
MOP	175	90	200	100	225	110	250	125	300	150

Notes:

- 1) FLA = Full Load Amps; MCA = Min Circuit Amps; MOP = Max Overcurrent Protection (Max Fuse Size)
- 2) - - - - Consult local AboveAir Sales Representative for non-cataloged system power supply information.

OUTDOOR, DX - AIR COOLED, REMOTE CONDENSERS

Unit Size (Nominal)	Condenser Model	Main Power Supply	Type	Cond Fan Motor				Unit Nameplate Data		
				Qty.	kW (HP)	FLA ea	Type	FLA	MCA	MOP
21-35kW (6.0-10.0T)	XPX-021D/035D-3*	208/3/60	Outdoor Pad/Roof Mtd	2	3.32 (4.45)	5.70	EC Axial	11.4	14.3	25
	XPX-021D/035D-4*	460/3/60	Outdoor Pad/Roof Mtd	2	3.32 (4.45)	4.50	EC Axial	9.0	11.3	20
42-105kW (12.0-30.0T)	XPX-042D/105D-3*	208/3/60	Outdoor Pad/Roof Mtd	2	3.35 (4.49)	5.47	EC Axial	10.9	13.7	20
	XPX-042D/105D-4*	460/3/60	Outdoor Pad/Roof Mtd	2	3.35 (4.49)	4.65	EC Axial	9.3	11.6	20

Notes:

- 1) FLA = Full Load Amps; MCA = Min Circuit Amps; MOP = Max Overcurrent Protection (Max Fuse Size)
- 2) - - - - Consult local AboveAir Sales Representative for non-cataloged system power supply information.

Typical Wiring Schematic - MC2-DX (21-105kW, 6-30 Tons)

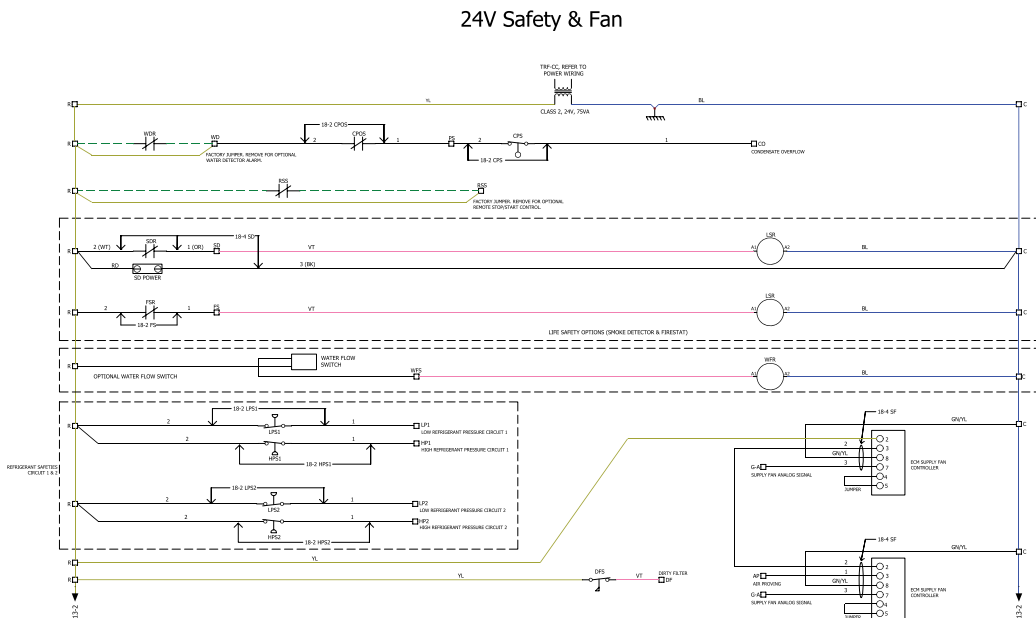
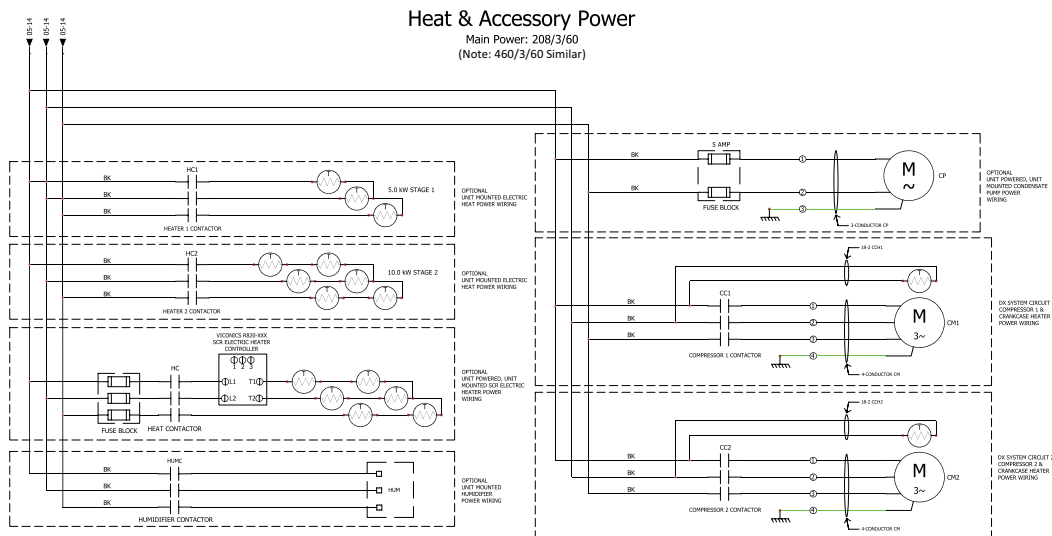
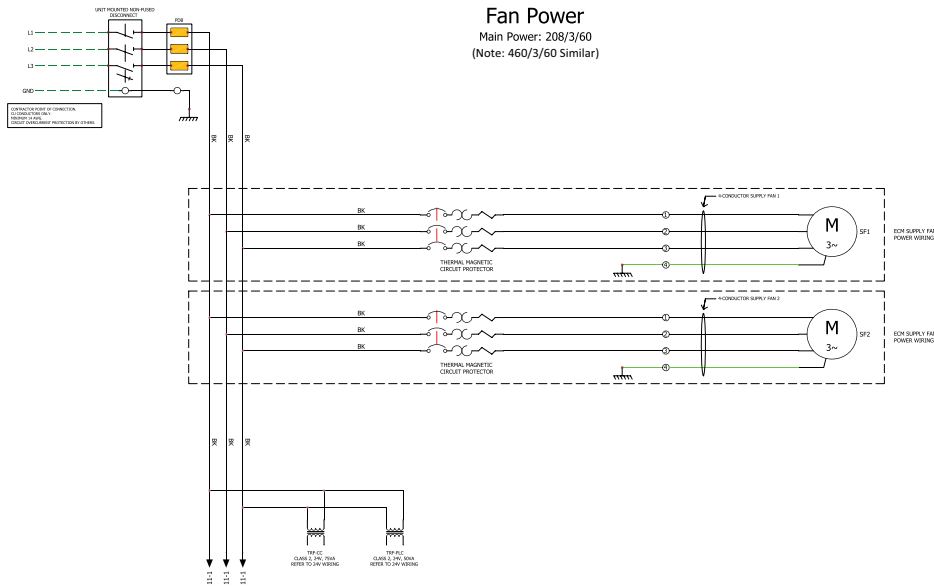

Typical Wiring Schematic - MC2-DX (21-105kW, 6-30 Tons)

24V Cooling

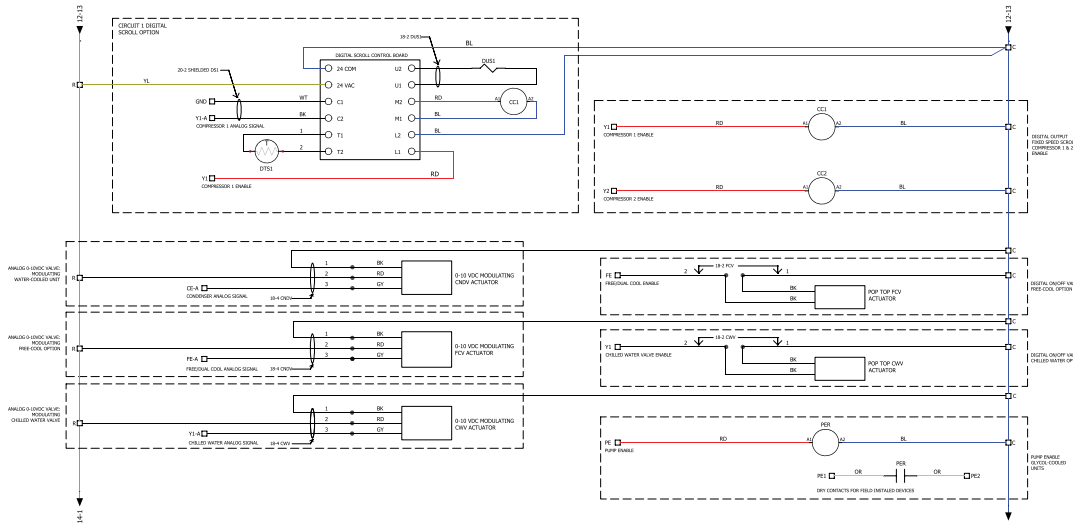

24V Heat & Humidification

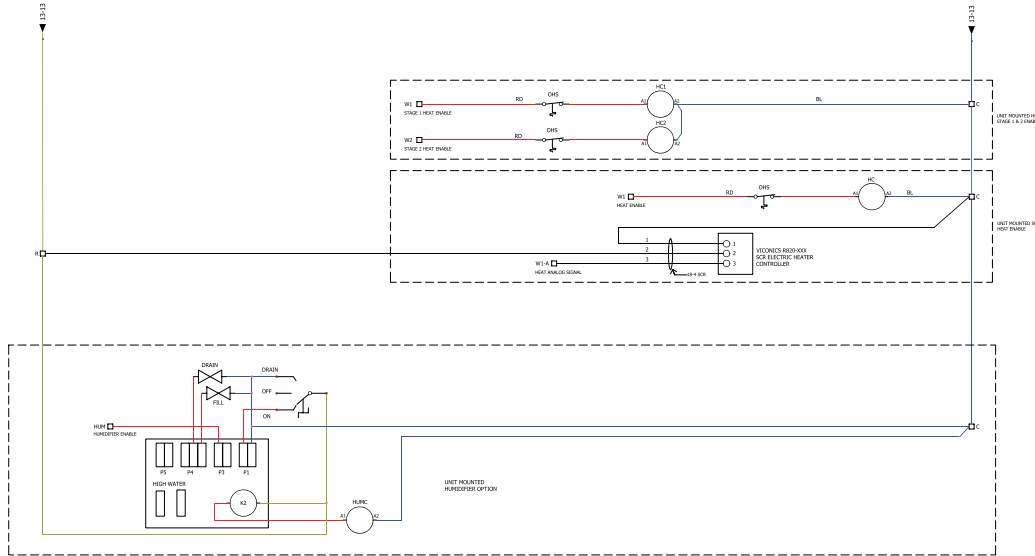

Sample Control Wiring

Control Sequence: MC-2000S UH

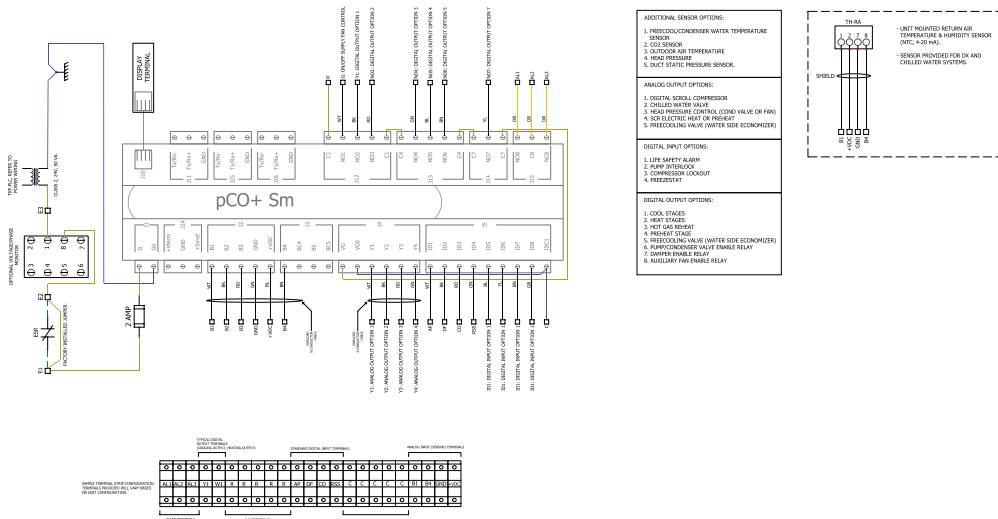

Recommended Clearance - MC2-DX (21-105kW, 6-30 Tons)

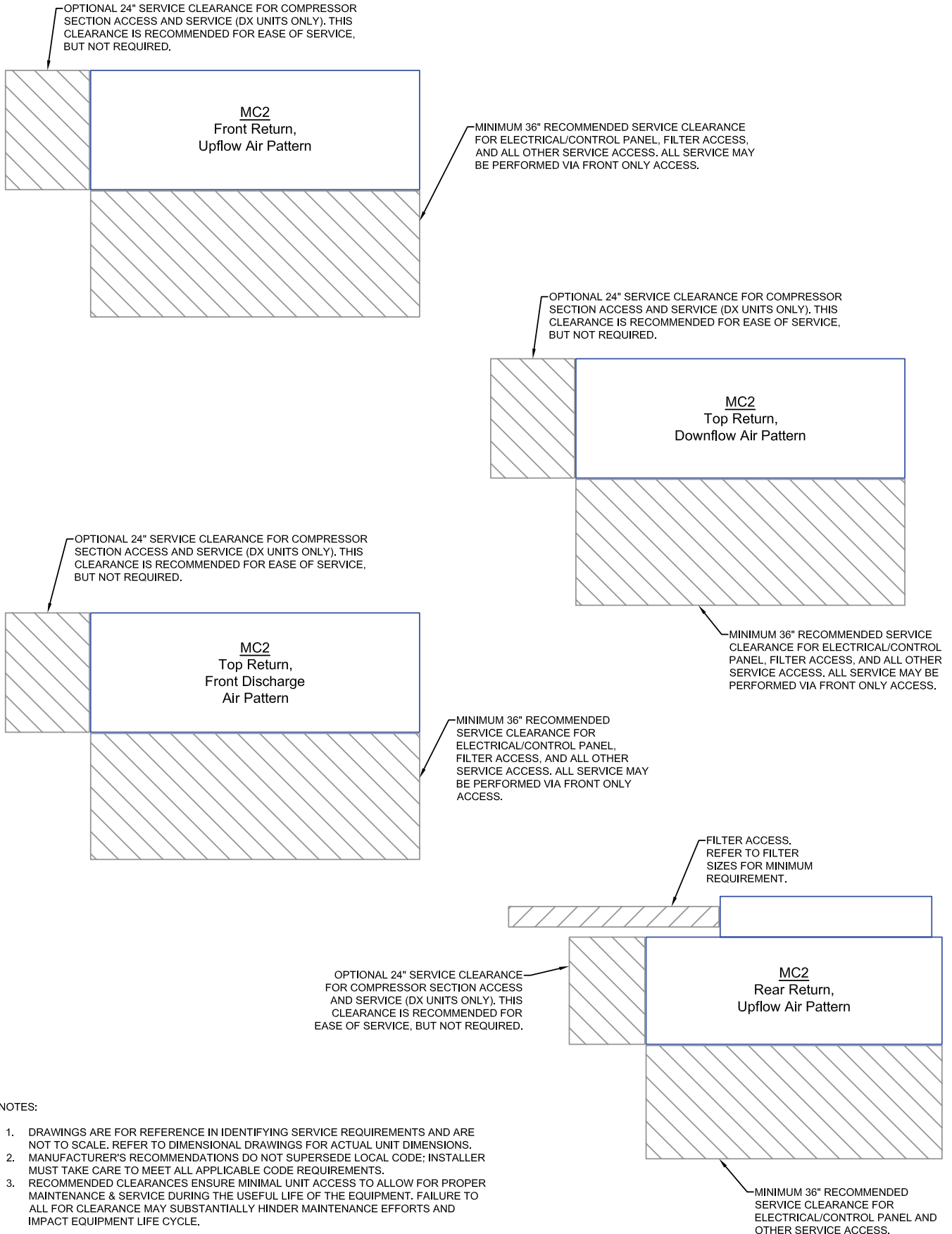

NOTES:

1. DRAWINGS ARE FOR REFERENCE IN IDENTIFYING SERVICE REQUIREMENTS AND ARE NOT TO SCALE. REFER TO DIMENSIONAL DRAWINGS FOR ACTUAL UNIT DIMENSIONS.
2. MANUFACTURER'S RECOMMENDATIONS DO NOT SUPERSEDE LOCAL CODE; INSTALLER MUST TAKE CARE TO MEET ALL APPLICABLE CODE REQUIREMENTS.
3. RECOMMENDED CLEARANCES ENSURE MINIMAL UNIT ACCESS TO ALLOW FOR PROPER MAINTENANCE & SERVICE DURING THE USEFUL LIFE OF THE EQUIPMENT. FAILURE TO ALL FOR CLEARANCE MAY SUBSTANTIALLY HINDER MAINTENANCE EFFORTS AND IMPACT EQUIPMENT LIFE CYCLE.

DX - Air Cooled, MCE & XPX-()

DX - Air Cooled Split with Propeller Fan, Outdoor Remote Condenser

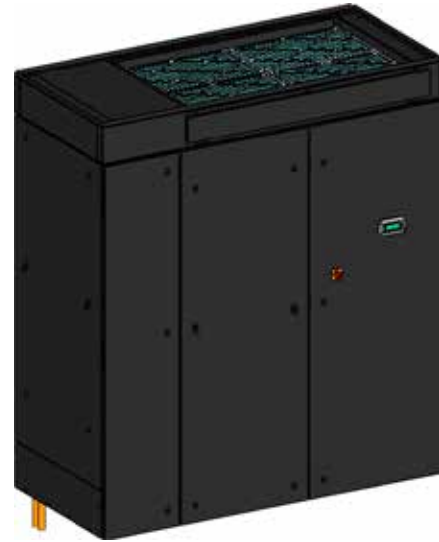
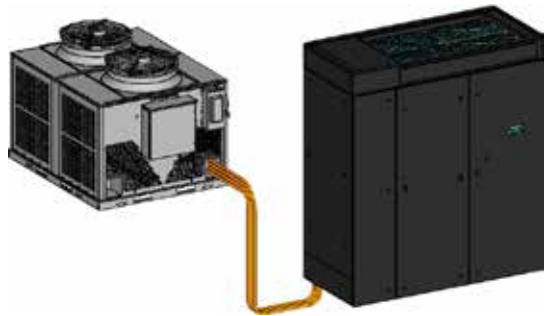

Down-Flow Air Pattern

DX - Water Cooled, MCW-()

DX - Water Cooled Self-Contained (Optional Free-Cooling Economizers!)

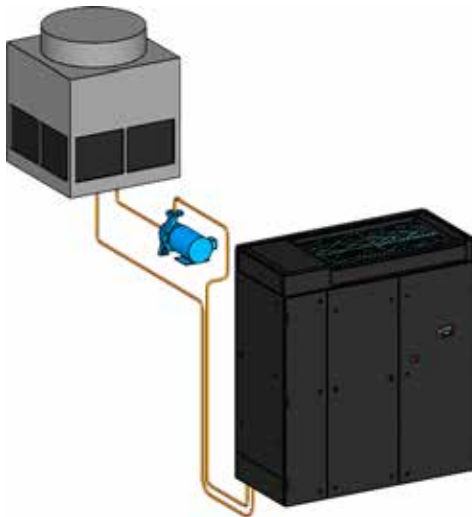

Up-Flow Air Pattern

DX - Glycol Cooled, MCG-()

DX - Glycol Cooled Self-Contained Plus Glycol Drycoolers & Pump Packages (Optional Free-Cooling Economizers!)

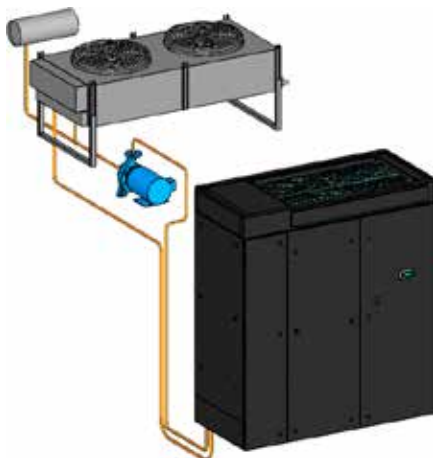

DOWN-FLOW: 21-35KW (6-10T), MC*-DF-A2 Cabinet

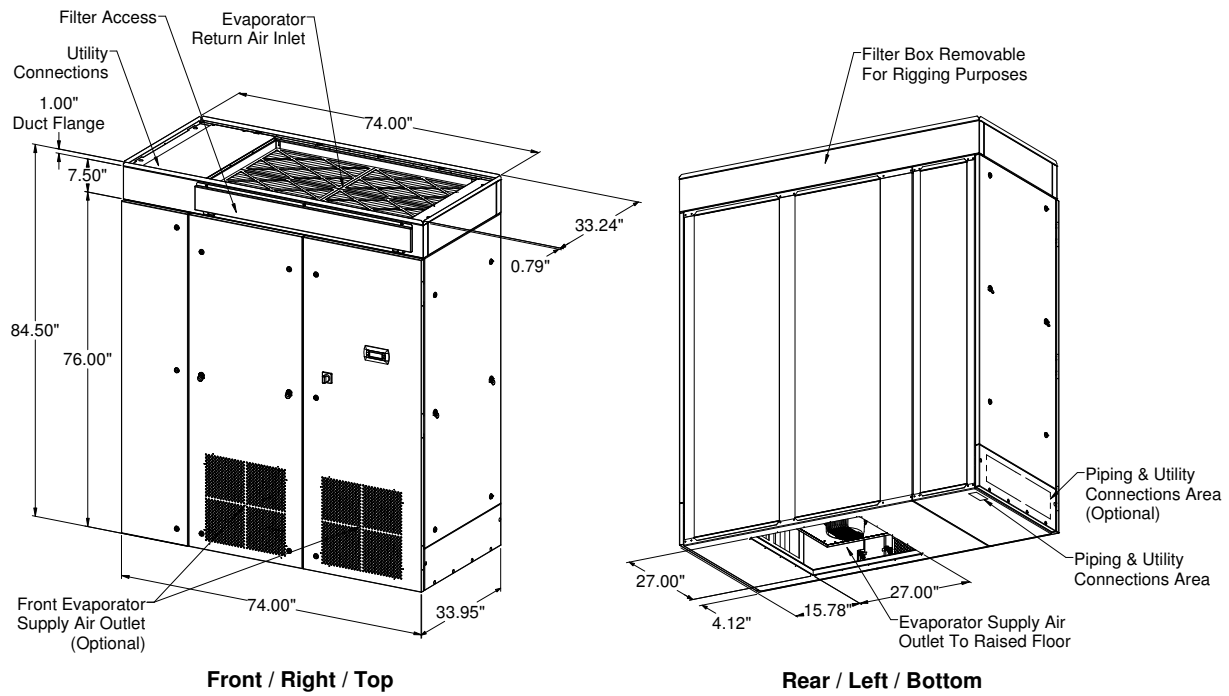

DOWN-FLOW: 42-70kW (12-20T), MC*-DF-B2 & C2 Cabinet

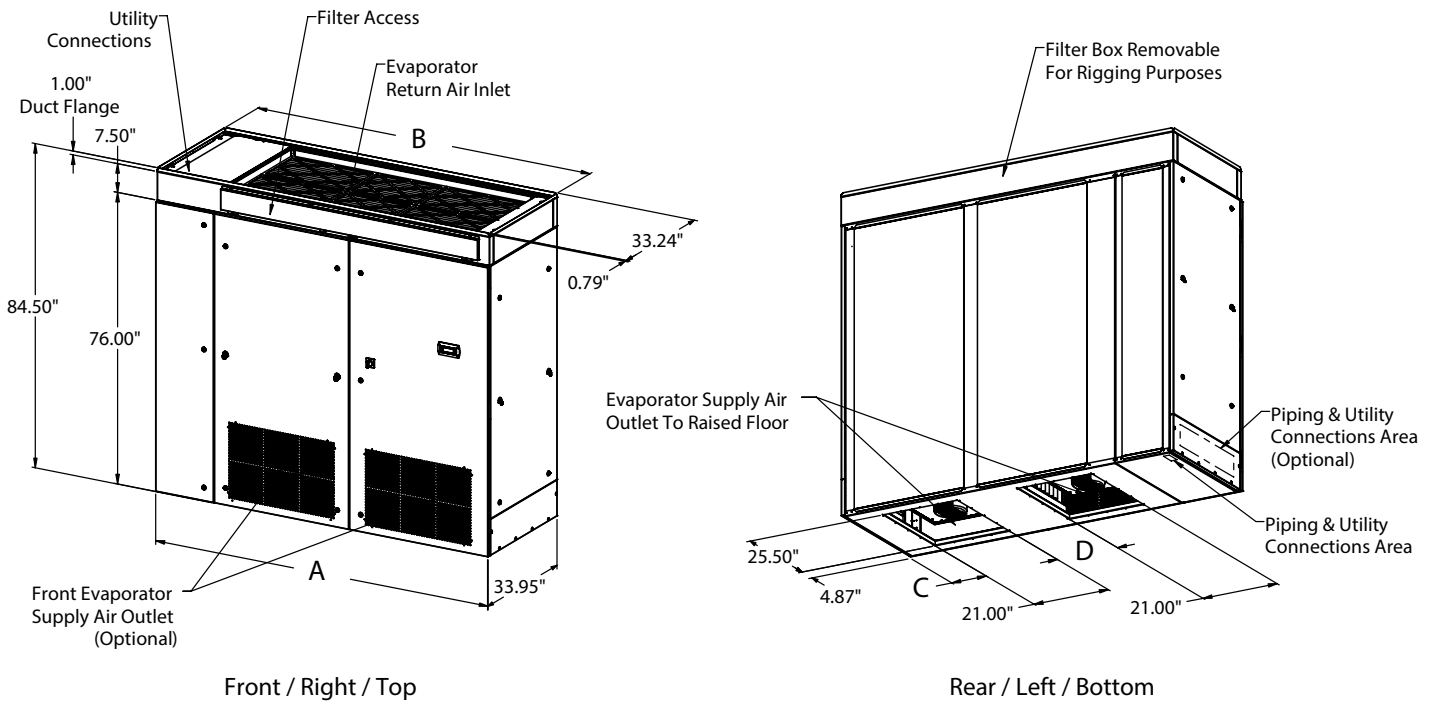

Unit Size	Model	A	B	C	D
42-53kW (12-15T)	MCE,W,G-042D/053D-*-DF-B2	94.00"	94.00"	9.78"	17.00"
63-70kW (18-20T)	MCE,W,G-063D/070D-*-DF-C2	109.00"	109.00"	11.78"	21.00"

DOWN-FLOW: 88-105kW (25-30T), MC*-DF-D2 & E2 Cabinet

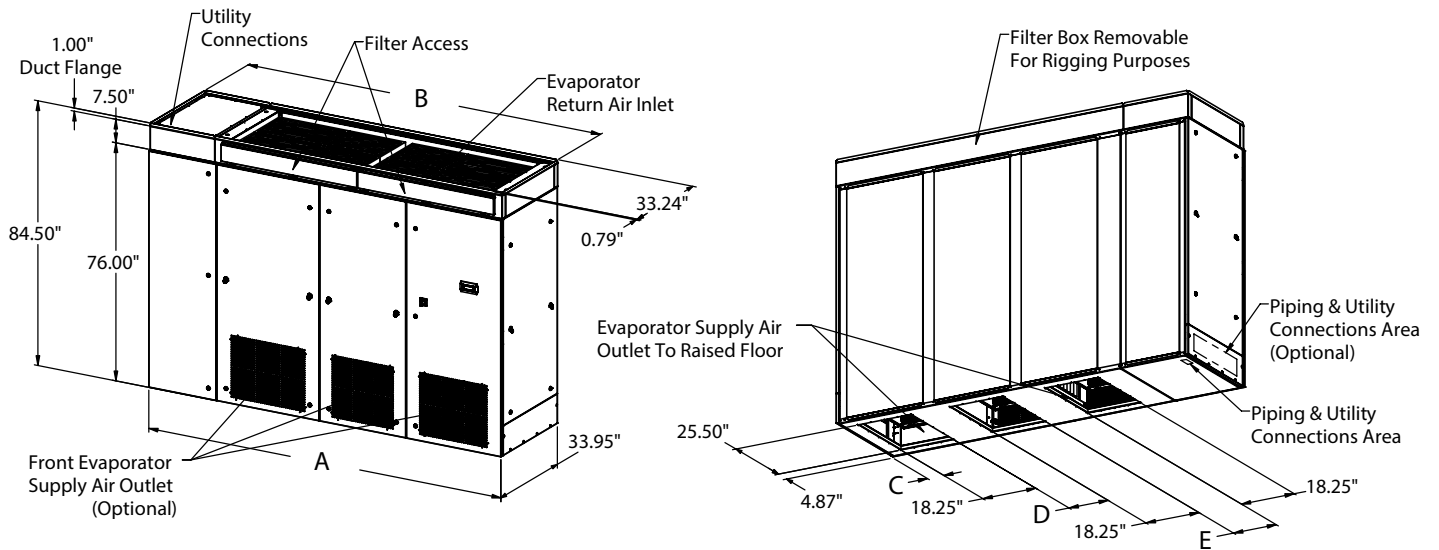

Front / Right / Top

Rear / Left / Bottom

Unit Size	Model	A	B	C	D	E
88kW (25T)	MCE,W,G-088D-*-DF-D2	122.00"	122.00"	5.66"	13.50"	14.75"
97-105kW (27.5-30T)	MCE,W,G-097D/105D-*-DF-E2	132.00"	132.00"	6.41"	15.50"	18.00"

UP-FLOW: 21-35KW (6-10T), MC*-UF-A2 Cabinet

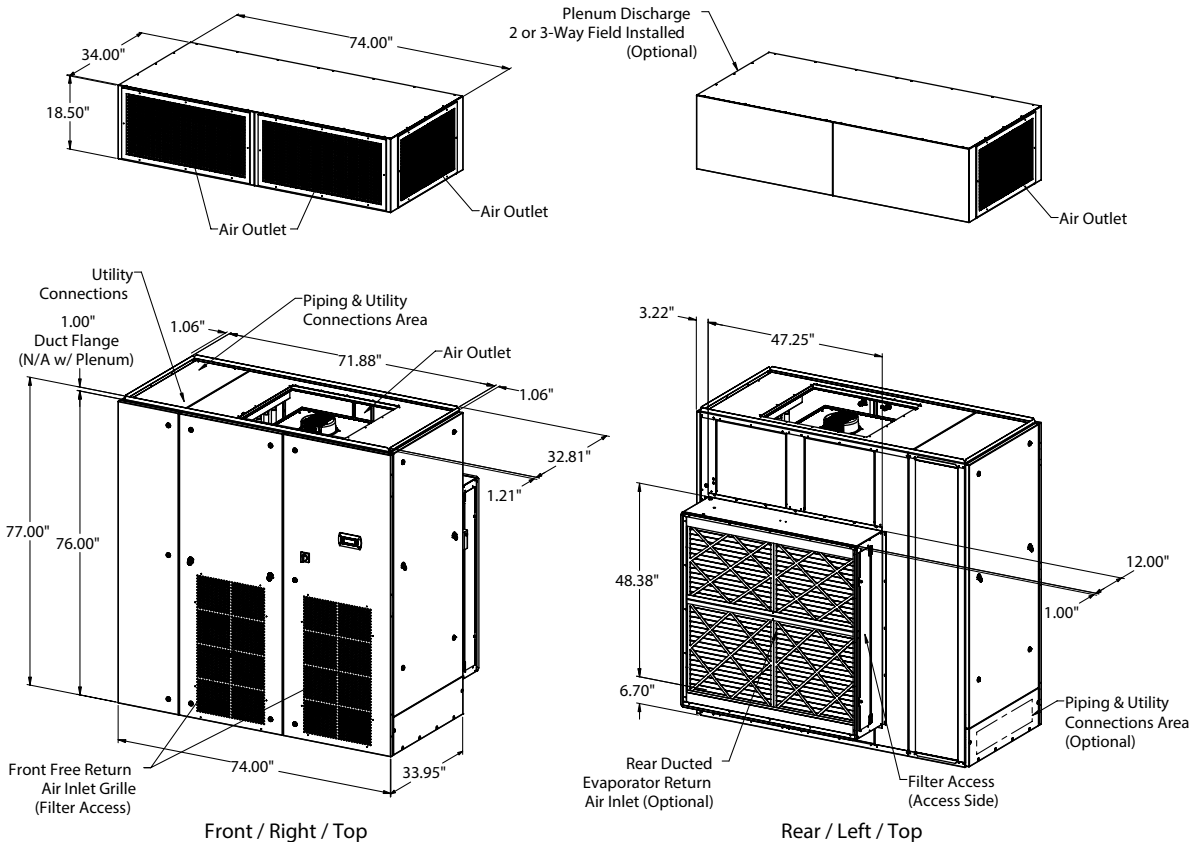

Front / Right / Top

Rear / Left / Top

Dimensional Data

UP-FLOW: 42-70kW (12-20T), MC*-UF-B2 & C2 Cabinet

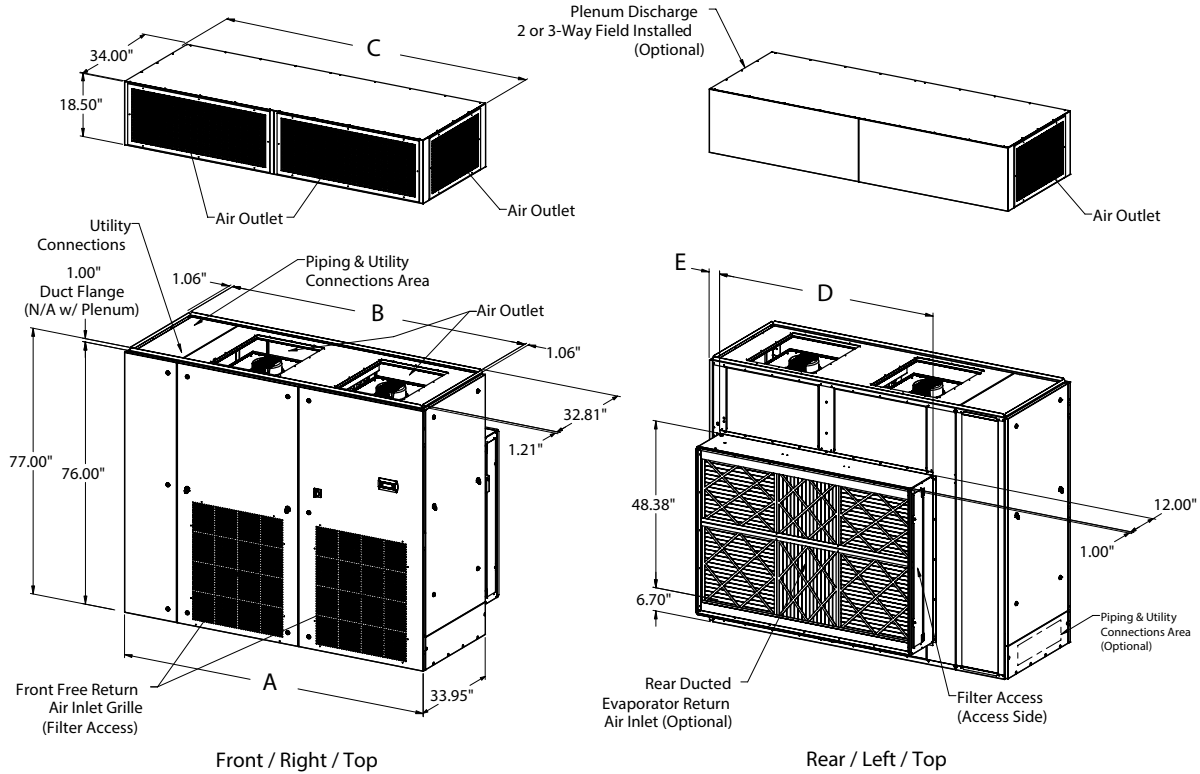

Unit Size	Model	A	B	C	D	E
42-53kW (12-15T)	MCE,W,G-042D/053D-*-UF-B2	94.00"	91.88"	94.00"	67.13"	3.28"
63-70kW (18-20T)	MCE,W,G-063D/070D-*-UF-C2	109.00"	106.88"	109.00"	71.13"	5.28"

UP-FLOW: 88-105kW (25-30T), MC*-UF-D2 & E2 Cabinet

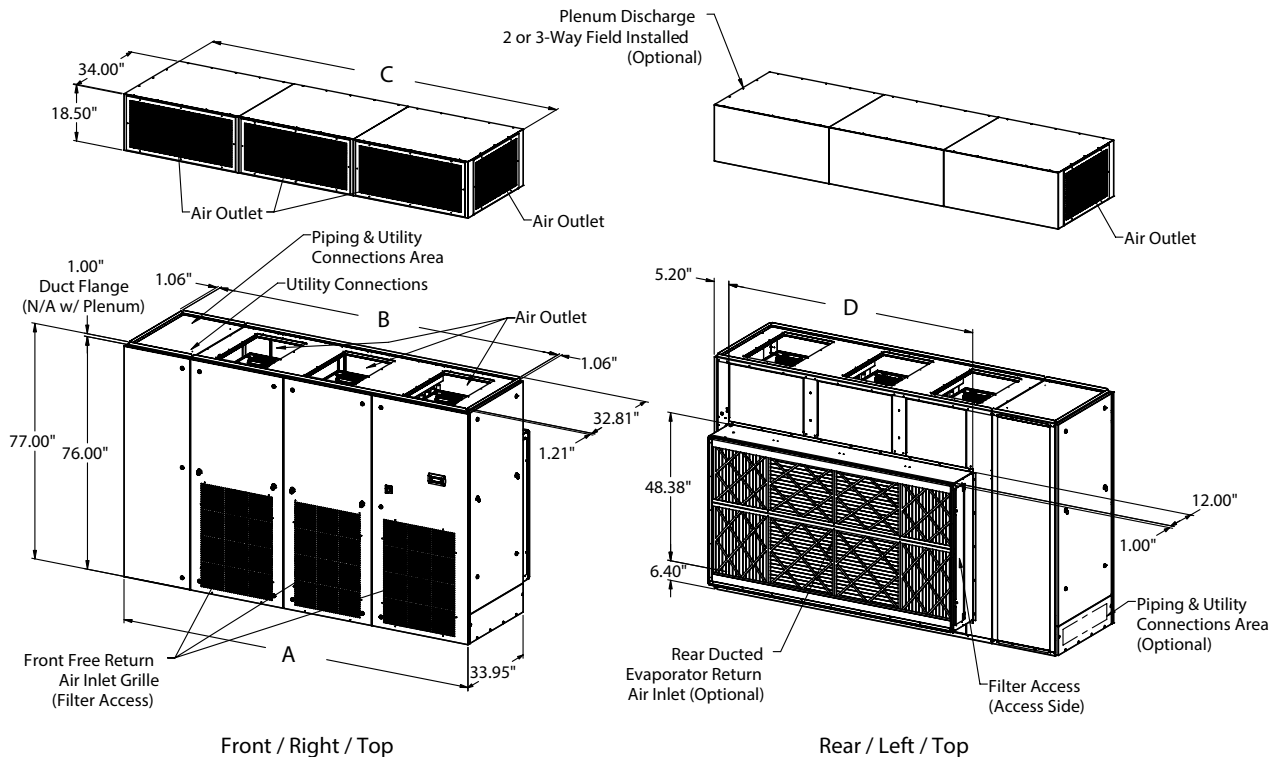

Unit Size	Model	A	B	C	D
88kW (25T)	MCE,W,G-088D-*-UF-D2	122.00"	119.88"	122.00"	86.50"
97-105kW (27.5-30T)	MCE,W,G-097D/105D-*-UF-E2	132.00"	129.88"	132.00"	94.50"

Floor Stand Options

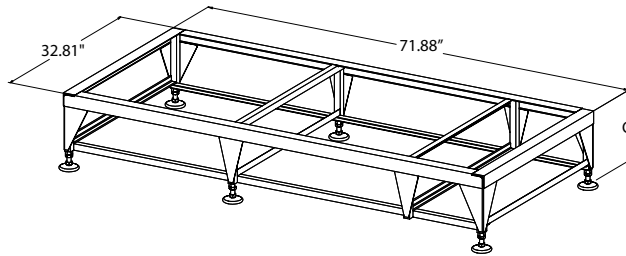

A-Cabinet ... 21-35kW (6-10 Tons)

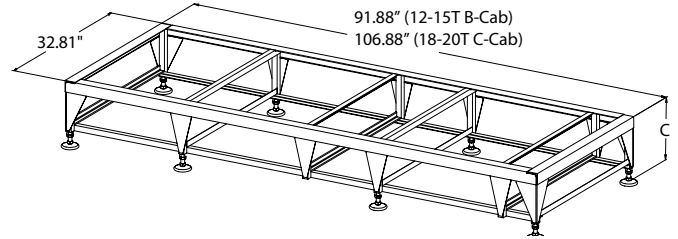

B & C-Cabinets ... 42-70kW (12-20 Tons)

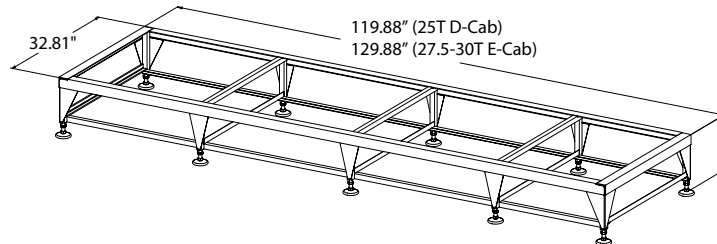

D & E-Cabinets ... 88-105kW (25-30 Tons)

Floor Stand Model (MC2-DX)	Nominal Height "C"	Nominal Weight (lbs) - (Shipping Skid Not Included)									
		A-Cabinet (21-35kW, 6-10T)		B-Cabinet (42-53kW, 12-15T)		C-Cabinet (63-70kW, 18-20T)		D-Cabinet (88kW, 25T)		E-Cabinet (97-105kW, 27.5-30T)	
		Floor Stand	Turning Vane	Floor Stand	Turning Vane	Floor Stand	Turning Vane	Floor Stand	Turning Vane	Floor Stand	Turning Vane
FS2P-04	4.0" (3.75"-4.75" Adj.)	53	N/A	67	N/A	73	N/A	79	N/A	83	N/A
FS2P-05	5.0" (4.25"-5.38" Adj.)	53	N/A	67	N/A	73	N/A	79	N/A	83	N/A
FS2P-06	6.0" (5.25"-8.25" Adj.)	53	N/A	67	N/A	74	N/A	80	N/A	84	N/A
FS2P-09	9.0" (8.25"-11.25" Adj.)	57	N/A	73	N/A	79	N/A	86	N/A	90	N/A
FS2P-12	12.0" (11.25"-14.25" Adj.)	81	18	107	29	115	30	117	40	123	40
FS2P-15	15.0" (14.25"-17.25" Adj.)	86	20	114	32	122	32	123	43	128	43
FS2P-18	18.0" (17.25"-20.25" Adj.)	90	23	120	37	128	38	128	49	134	49
FS2P-24	24.0" (23.25"-26.25" Adj.)	99	26	133	43	141	44	139	58	145	58

Outdoor, DX - Air Cooled Propeller Fan, Remote Condensers

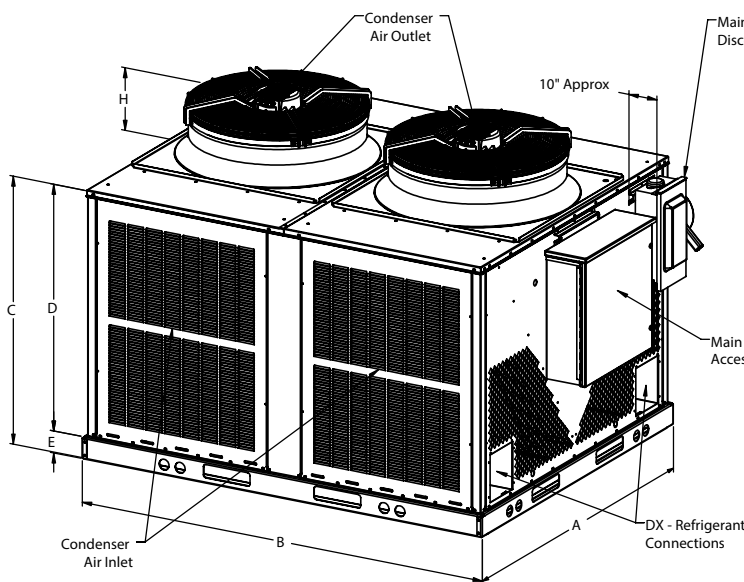

Front / Top / Right

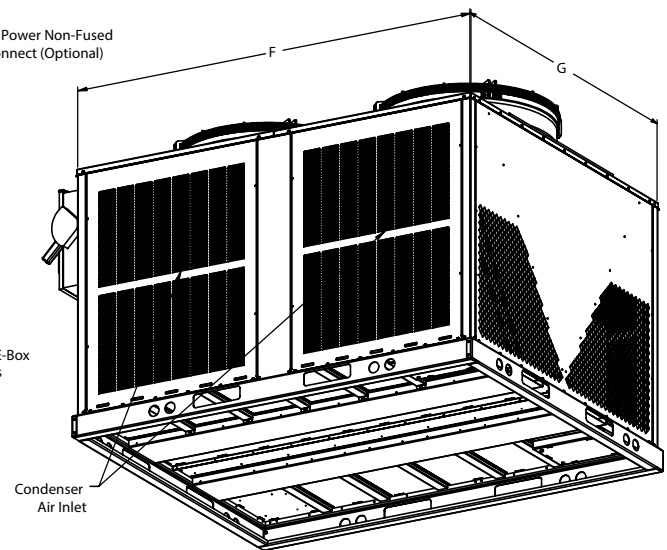

Rear / Left / Bottom

Unit Size	Model	A	B	C	D	E	F	G	H
6-35kW (6-10T)	XPX-021D/035D-*	63.69"	72.70"	48.38"	44.25"	4.13"	71.25"	62.00"	9.33"
42-70kW (12-20T)	XPX-042D/070D-*	67.69"	81.45"	50.38"	46.25"	4.13"	80.00"	66.00"	11.81"
88-105kW (25-30T)	XPX-088D/105D-*	67.69"	86.45"	50.38"	46.25"	4.13"	85.00"	66.00"	11.81"

Innovative HVAC Solutions

MissionCritical Units - Precision A/C's



**SC-2x4 SpotCool
Ceiling Mounted A/C's**
(4-11kW, 1-3 Tons)



**HK Horizontal Ducted
Ceiling Mounted A/C's**
(4-70kW, 1-20 Tons)



**MC Vertical Floor Mtd A/C's
Up-Flow & Down-Flow**
(4-1080kW, 1-307 Tons)



**WC Wall-Cassette and
FC Floor-Console Mtd A/C's**
(4-18kW, 1-5 Tons)

Outdoor-Air Units - IAQ High Percent (20%-100% OA)



HK-OA Horizontal Ceiling Mtd
(1-30 Tons)



VK-OA Vertical Floor Mtd
(1-50 Tons)

Specialty Units - A/C's & Water Source Heat Pumps



**SC-2x4 SpotCool
Ceiling Mtd A/C's**
(4-11kW, 1-3 Tons)



**HK Horizontal Packaged
& Split Ceiling Mtd A/C's**
(4-70kW, 1-20 Tons)



**VK Vertical Packaged &
Split Floor Mtd A/C's**
(4-105kW, 1-30 Tons)

Remote Heat Rejection Units



**Remote Air Cooled
Condensers, Condensing Units &
Glycol Drycoolers**

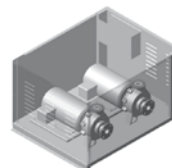

**Single, Dual & Triplex
Glycol Pump Packages**
(1/2 to 50 HP, VFD Optional)