

Engineering Manual

MC2™ CW

Mission Critical

Vertical Floor Mounted A/C's
(Chilled Water Systems)

Features & Benefits

- > 21-105kW (6-30 Tons) Capacities
- > Precision Applications
 - Data Center/Colocation/Hosting for Banks, Financial, Healthcare, Government, Retail and Wholesale Institutions!
- > Vertical Floor Mounted Upflow & Downflow Configurations
- > Chilled Water Systems (up to 6 Rows!)
- > Energy Efficiency Variable Speed EC Plug Fans!
- > Compact 34" Deep Cabinets!
- > Total Temp & Humidity Control
 - Electric Reheat/Heat
 - Steam Humidifier
- > Microprocessor Controls & More

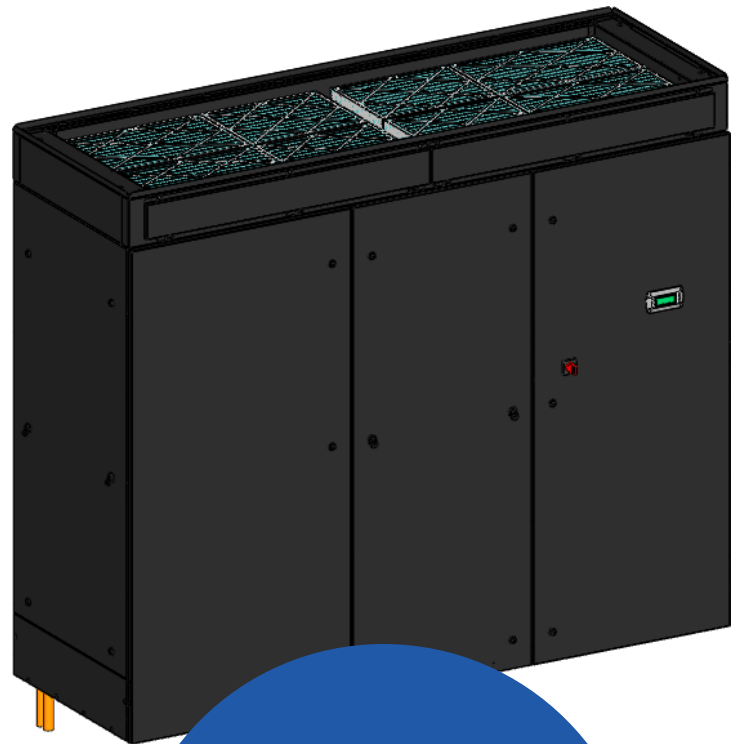

**From
21-105kW**

**Data Center/
Colocation/Hosting**

AboveAir™ MissionCritical™ vertical floor mounted precision air conditioners are the reliable environmental control solution to your precision cooling needs. Available in a wide variety of cooling methods and cabinet configurations including a full range of options, **AboveAir™** Air Conditioners are a step above!

- ☑ 100% Front-Access cabinet design
- ☑ Total Temperature & Humidity Control
- ☑ Up-Flow & Down-Flow air patterns
- ☑ Compact Rigging with 34" Depth Cabinets!
- ☑ Flexible options and accessories
- ☑ EC Backward-Inclined Plug Fans
- ☑ Energy efficient operation

Contents	
Introduction	2
Features and Benefits	3
Model Nomenclature	4
Guide Specifications	5-7
Up-Flow (45°F EWT) - Cooling Capacity	8-9
Down-Flow (45°F EWT) - Cooling Capacity	10-11
Physical Data	12-13
Electrical Data	14-15
Typical Wiring Schematics	16-17
Recommended Service Clearance	18
Model Configurations	19
Dimensional Data	20-23
Other AboveAir Products	Back Cover!

Chilled Water, MCC-()

Chilled Water Air Handling Systems (Chiller by Others)

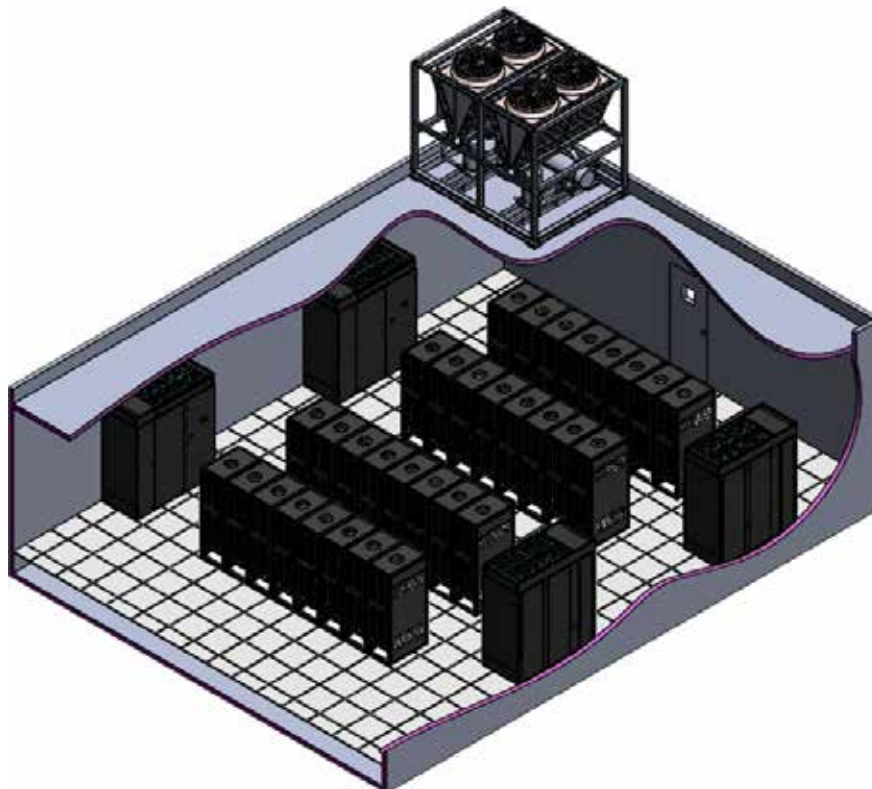

AboveAir™ MissionCritical™ precision A/C's are designed to meet your unique application dependent requirements. Select from a wide range of options and configurations:



Up-Flow Air Pattern

**21-105kW
(6-30T)**



Down-Flow Air Pattern

Variety of Standard & Optional Features



Standard & Optional Features:

- MC-6000, Advanced Microprocessor Controls
- Electrode Steam Canister Humidifier
- Electric Reheat/Heat
- EC Backward-Inclined Plug Fans
- High Efficiency Air Filtration
- 2 & 3-way 580 psig Rated Modulating Chilled Water Control Valves
- Compact Rigging with 34" Depth Cabinets!
- Top, Bottom & Side Piping Connections

Accessories:

- 2, 3-Way or Ducted Plenum Discharge Boxes
- Floor Stands & Turning Vanes
- Condensate Pumps - Factory Installed
- Main Power Electrical Disconnects
- Firestats & Smoke Detectors
- Remote Water-Leak Detectors
- ... and more!



Model Nomenclature

Chilled Water, Air Handling Systems

MC	C	- 070	X	- 4	- 00	ER	H	- EC	- 00	- UF0	- C2	- DX
a	b	- c	d	- e	- f	g	h	- i	- j	- k	- l	- m

- a: MC** - MissionCritical MC2 Vertical Floor A/C
- b: C** - Chilled Water Air Handling Unit
- c: 021** = 21kW (6.0T); **028** = 28kW (8.0T); **035** = 35kW (10.0T);
042 = 42kW (12.0T); **053** = 53kW (15.0T); **063** = 63kW (18.0T);
070 = 70kW (20.0T); **088** = 88kW (25.0T); **097** = 97kW (27.5T);
105 = 105kW (30.0T)
- d: X** - Chilled Water System
- e: 1** - 208-230V / 1 Ph / 60 Hz
3 - 208-230V / 3 Ph / 60 Hz
4 - 460-480V / 3 Ph / 60 Hz
5 - 575V / 3 Ph / 60 Hz
7 - 277V / 1 Ph / 60 Hz
8 - 460-480V / 1 Ph / 60 Hz
- f: 00** - None / Not Applicable
- g: 00** - No Unit Mtd Electric Heat
EO - Electric Heat Only, No Reheat
ER - Electric Reheat/Heat
- h: 0** - No Humidifier
H - Electrode Canister Steam Humidifier
- i: EC** - EC = EC Plug Fan (Direct-Drive, Backward-Inclined Centrifugal Impeller, 0-10Vdc)
- j: 00** - No Economizer
DC - Dual-Cool / Alternate Water Source Coil
- k: DFB** - Down-Flow Evap Air Pattern w/ Free or Ducted Top Return & Bottom Discharge to Raised Floor
DFF - Down-Flow Evap Air Pattern w/ Free or Ducted Top Return & Front Free-Discharge to Floor Level
UF0 - Up-Flow Evap Air Pattern w/ Front Free-Return & Top Ducted Discharge
UF1 - Up-Flow Evap Air Pattern w/ Front Free-Return & Top 1-Way Plenum Discharge Box
UF2 - Up-Flow Evap Air Pattern w/ Front Free-Return & Top 2-Way Plenum Discharge Box
UF3 - Up-Flow Evap Air Pattern w/ Front Free-Return & Top 3-Way Plenum Discharge Box
UFR - Up-Flow Evap Air Pattern w/ Rear Ducted or Free-Return & Top Ducted Discharge
- l: C2** - MC2 Cabinet Size ... A2 = 21-35kW (6-10T); B2 = 42-53kW (12-15T); C2 = 63-70kW (18-20T); D2 = 88kW (25T); E2 = 97-105kW (27.5-30T)
- m: CX** - Chilled Water Valve - 2-Way, 580 psi (MOD, 0-10 VDC)
DX - Chilled Water Valve - 3-Way, 580 psi (MOD, 0-10 VDC)
EX - Chilled Water Valve by Others

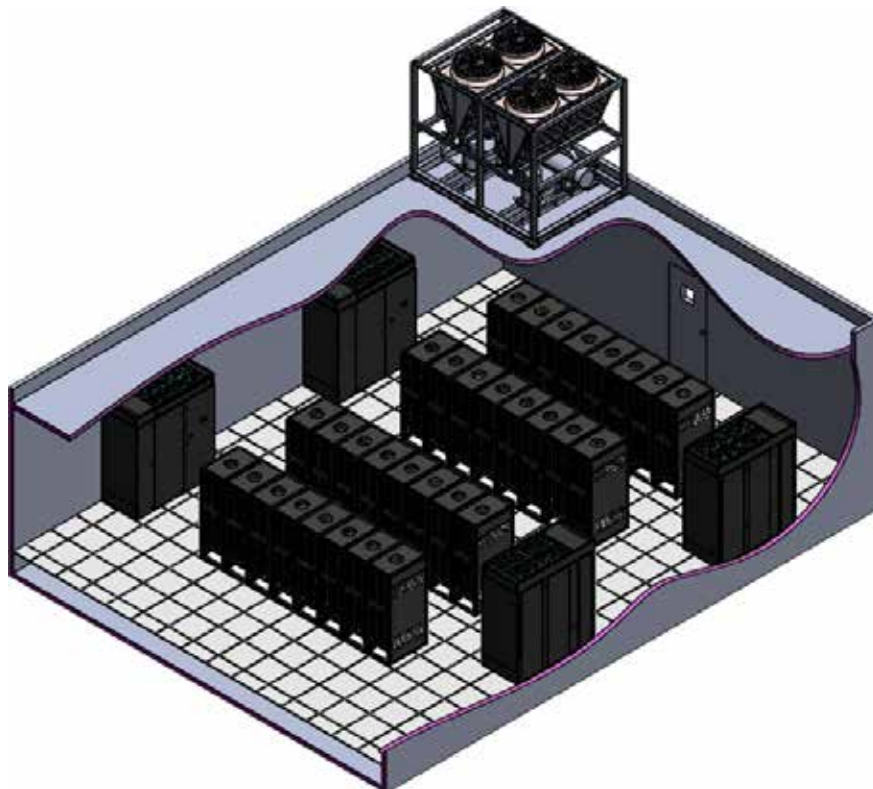

General

Summary



These specifications describe the requirements for a vertical floor mounted precision air conditioner. The system shall be designed to control space temperature and humidity.

The air conditioning manufacturer shall design and furnish all equipment in the quantities and configurations shown on the project plans and specifications.

The system shall be provided by AboveAir Technologies in Frederick, Maryland, USA. The system shall be listed by Intertek (ETL Semko), Inc. to conform with UL Std 1995 and be certified to CAN/CSA Std C22.2 No. 236 (Control No. 3091370). The system shall be NYC MEA229-06-E and Chicago Code Approved. The system model number shall be _____.

Design Requirements

The system shall be an AboveAir Technologies MissionCritical™ brand, factory assembled and tested. The system shall be designed for indoor installation.

The system shall have a total cooling capacity of _____ BTU/H, and a sensible cooling capacity of _____ BTU/H, based on an entering air condition of _____ °F DB, and _____ °F WB, _____ % RH.

The evaporator section shall be designed for _____ Volt, _____ Phase, _____ Hertz main power supply. The remote condensing unit section (if applicable) shall be designed for _____ Volt, _____ Phase, _____ Hertz main power supply.

Submittals

Submittals shall be provided after manufacturer's receipt of a written purchase order and shall include: Detailed Performance and Electrical Data; Guide Specifications; and Dimensional Drawings.

Quality Assurance

The system shall be factory run tested prior to shipment. Testing shall include, but shall not be limited to: "HiPot" Test (2 times rated voltage plus 1000 volts, per UL 1995 testing requirements). The system shall be designed and manufactured according to world class quality standards.

Products

Standard Features

Cabinet

The cabinet chassis and access panels shall be powder-coat painted heavy gauge galvanneal steel for decor matching and corrosion resistance. Cabinet access panels shall rest in recessed pockets designed for minimum air leakage. The cabinet and access panels shall be lined with 2 lb/ft² high density sound and thermal insulation and sealed with self-extinguishing gasketing conforming to NFPA 90A and 90B.

Component Access (100% Front Only!)

The unit shall be serviceable through front only access panels with quick-release quarter-turn fasteners.

Electrical System

General:

The electrical system shall conform to National Electric Code (NEC) requirements according to UL 1995. The control circuit shall be a 24 VAC low voltage circuit.

The electrical system shall include, but not be limited to the following factory installed items: main power distribution block; grounding lug; 24 VAC control transformer; terminal connections; and motor controllers with start protection and circuit breakers for blower motors, compressors and each electric heater stage (if applicable).

Overflow Safety Float Switch:

The system shall be provided with a factory installed float type condensate overflow safety switch. The circuit shall be designed to shut down all system water producing operations in the event of an overflow condition.

Main Power, Disconnect (MCC Evap Section)



The indoor air handler shall be provided with a factory installed main power non-fused disconnect. The disconnect shall be NEMA rated for indoor or outdoor installation as required.

Air Distribution

Supply Fan - EC BI Plug Type!



The evaporator blower assembly shall be a backward-inclined direct-drive centrifugal impeller with variable speed EC (electronically commutated) motor. The blower shall be designed for _____ CFM @ _____ inches external static pressure (e.s.p.)

Variety of Air Patterns



Up-Flow (UF)

Down-Flow (DF)

Up-Flow Air Pattern:

UF*: Front-Free Return

The system shall be configured for up-flow air handler air pattern with front-free return and top discharge. (Refer to Plenum Discharge Box Options.)

UR*: Rear-Ducted Return

The system shall be configured for up-flow air handler air pattern with rear ducted return and top discharge.

Down-Flow Air Pattern:

DFB: Bottom Disch Into Raised Floor

The system shall be configured for down-flow air handler air pattern with top free or ducted return and bottom discharge into raised floor. (Refer to Floor Stand Options.)

DFE: Front Discharge Floor Level

The system shall be configured for down-flow air handler air pattern with top free or ducted return and front free discharge to floor level.

Air Filtration



The return air filters shall be 4 inch thick pleated and Merv-8 efficiency rated (based on ASHRAE 52.2). The filters shall be serviceable without shutting down the system.

Piping Connection Location

- Top Piping Connections
- Lower-Side Piping Connections
- Bottom Piping Connections

Cooling Configurations

Chilled Water Systems MCC(-)



The system shall be a compact indoor vertical floor mounted chilled water precision air conditioner.

The chilled water cooling coil shall be constructed of copper tubes and aluminum fins. Coil end-plates shall be hot dipped galvanized. The cooling coil shall be mounted in an insulated stainless steel condensate drain pan.

Chilled water flow shall be controlled by a factory installed 2 or 3-Way Modulating (0-10Vdc) chilled water control valve rated for a maximum 580 psig w.w.p.

Options

Chilled Water Coil Control Valves



Modulating Valves, 0-10Vdc:

- 2-Way, 580 psig (0-10Vdc, NC)
- 3-Way, 580 psig (0-10Vdc, NC)

A ___-way chilled water coil control valve shall be factory installed within the air conditioning unit. The valve shall provide precision space cooling and/or dehumidification control. The valve shall be the 24 VAC, ___-Way, Modulating (0-10Vdc) 580 psig rated, normally closed type.

CONTROL OPTIONS

MC-6000™, Advanced Temp/Humid Microprocessor Controller w/ Alarms & BMS Connection



The system shall be provided with a MC-6000™ advanced microprocessor based temperature and humidity controller with alarms.

Supply Fan Control Options:

- Constant Supply Fan Speed Control (Based on manual set point.)
- Variable Supply Fan Speed Control (Based on space temperature.)

Select Features/Benefits:

- 4x20 Character Liquid Crystal Alpha-numerical Display
- User Configurable
- Run-Time Hours
- Current Unit Mode Status
- Alarm Status
- Digital & Analog Inputs / Outputs
- Temperature Anticipation
- Remote Stop / Start Contact
- Summary Alarm Contact
- Automatic or Manual (selectable) Restart After Power Loss
- Sequential Load After Restart
- Recovery Delay
- Security Password Access
- Self-Diagnostics
- Service Mode

Unit Status Display

The control system shall display current unit functions and room status (if applicable):

- Current Dry Bulb Temp Set Point
- Current Relative Humidity Set Point
- System ON/OFF
- Cooling
- Heating
- Humidifying
- Dehumidifying
- Reheating
- Actual Room DB Temperature
- Actual Room Relative Humidity

Alarm Conditions:

Alarm conditions activate an audible and visual indicator plus close a summary alarm dry contact connection. The control system shall alert to the following alarm conditions (if applicable):

- High / Low Temp
- Smoke Detection
- Summary Alarm
- Sensor Failure
- Loss of Air Flow
- High/Lo Humidity
- Firestat
- Leak Detection
- Loss of Power
- Dirty Filter

Digital & Analog Control Inputs / Outputs:

The control system shall be capable of both digital (ON/OFF) and analog (proportional integral, PI) input and output control.

Select MC-6000 Options:

- Multi-Unit N+1 Sequencing
- BMS Communications Interface:
 - BACnet over MS/TP (RS485 Serial)
 - BACnet Over IP (Ethernet / EIA485)
 - ModBus RS485 Serial Connection

Heat / Reheat Options

Electric Reheat/Heat



An electric heating system shall be factory installed to provide:

- Electric Heat Only during heat mode
- Electric Reheat to offset sensible cooling during the dehumidification mode and to provide heating during heat mode.

Heater elements shall be the low-watt density finned-tubular type. The heater shall be complete with individual heater stage starter/contactors and overheat safeties. Systems incorporating factory installed electric heaters shall require

only single point power to the main unit power distribution. The electric heat shall have a capacity of _____ BTU/H and a KW rating of ____ KW, controlled in ____ stages.

SCR Fired Heat/Reheat
(0-100% Modulating 0-10Vdc)

The electric heat/reheat shall be controlled through a “zero firing” silicon control rectifier (SCR) with an extruded aluminum heat sink and solid state logic system to provide close dry bulb temperature control of the leaving conditioned air temperature. The electric heat shall have a capacity of _____ BTUH and a KW rating of ____ KW.

Humidification Options

Steam Humidification



An electrode steam canister type humidification system shall be factory installed within the air conditioning system. The humidifier shall be complete with disposable canister, steam distributor, fill and drain valve, air gap, automatic flush cycle, manual humidity output adjustment and field installed remote wall mounted humidistat. The humidifier shall have a maximum output capacity of _____ lbs/hr.

Accessories

Plenum Discharge Box (UF - Up-Flow Units)

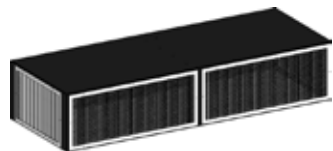

A 3-Way (or 2-Way) plenum discharge box shall be provided for field installation to the top of the up-flow unit. The plenum box shall be insulated and powder-coat painted to match the color of the unit. The plenum box supply grilles shall be the double deflection type with vertical blades in the front, horizontal blades in the back; both individually adjustable and on 2/3” spacing; aluminum roll-formed blade with semi-airfoil design; pressure fit nylon pivot pins (rattle free & non-loosening) and an aluminum extruded frame with mechanically locked corners.

Floor Stand



A _____ inch nominal high (____ in to ____ in adj. range) floor stand shall be factory provided for field installation. The floor stand shall have adjustable legs with vibration isolation.

Turning Vanes

Turning vanes shall be factory provided with the floor stand to direct the discharge air either to the front or rear of the unit.

Condensate Pump

(Factory Installed - Both UF & DF!)



A condensate pump shall be factory provided and installed within the indoor evaporator section (*Up-Flow & Down-Flow Air Pattern Configurations*). The condensate pump shall be provided with dual internal float switches: one for pump operation initiation and the other for pump reservoir overflow safety.

Remote Water-Leak Detector



A remote water-leak detector shall be factory provided for field installation. The remote water-leak detector shall be wired to shut down all A/C unit water producing functions upon sensing a water leak.

(Note: Cable Type Remote Water Detectors are also optionally available.)

Smoke Detector

(Factory Installed)



A Smoke Detector shall be factory installed in the return air stream of the unit and wired to the A/C unit electrical control panel. The Smoke Detector shall shut-down all A/C system operations upon activation.

Firestat

(Factory Installed)



A Firestat shall be factory installed in the return air stream of the unit and wired to the A/C unit electrical control panel. The Firestat shall shut-down all A/C system operations upon sensing a high return air temperature condition.

Mounting Vibration Isolators

Rubber/Cork Anti-Vibration Pads:



Each indoor vertical floor mounted section shall be provided with a set of quantity four (4”x4”x7/8”) Rubber/Cork Anti-Vibration Pad vibration mounting isolators.

Spring Mounting Isolators:



Each indoor vertical floor mounted section shall be provided with a set of quantity four adjustable spring vibration mounting isolators with non-skid neoprene acoustical isolation pads. Isolators shall be sized for the total distributive weight of the unit with a 1” deflection.

Cooling Capacity Data - Upflow MCC-UF (21-53kW, 6-15T, 45°F EWT)

UPFLOW - 45°F EWT (0% Glycol), Chilled Water Coil Cooling Capacities (21-53kW, 6-15T MCC-UF)

Chilled Water Design ΔT	Coil Size & Cabinet		MC2-A (21-35kW, 6-10 Tons)						MC2-B (42-53kW, 12-15 Tons)								
	Model		MCC-021X-...-UF		MCC-028X-...-UF		MCC-035X-...-UF		MCC-042X-...-UF		MCC-053X-...-UF						
	Nominal Capacity		21kW (6 Tons)		28kW (8 Tons)		35kW (10 Tons)		42kW (12 Tons)		53kW (15 Tons)						
	Supply Air CFM (CMH)		3,000 (5,097)		4,000 (6,796)		5,000 (8,495)		6,000 (10,194)		7,500 (12,743)						
	Coil Rows		3	4	6	3	4	6	3	4	6	3	4	6			
Net Cooling Capacity MBH (kW)																	
85°F DB / 65.9°F WB, 36% RH, (29.4°C DB / 18.8°C WB), 55°F DP																	
ΔT = 10°F 45° EWT 55° F LWT	Net Total	MBH (kW)	108.5 (31.8)	127.5 (37.4)	148.8 (43.6)	133.6 (39.2)	159.3 (46.7)	190.0 (55.7)	156.1 (45.7)	188.0 (55.1)	227.9 (66.8)	198.5 (58.2)	237.1 (69.5)	283.4 (83.1)	231.6 (67.9)	279.6 (81.9)	339.9 (99.6)
	Net Sensible	MBH (kW)	96.2 (28.2)	106.4 (31.2)	117.0 (34.3)	122.1 (35.8)	136.3 (39.9)	151.7 (44.5)	146.4 (42.9)	164.5 (48.2)	184.6 (54.1)	182.2 (53.4)	203.6 (59.7)	226.7 (66.4)	218.4 (64.0)	245.6 (72.0)	275.8 (80.8)
	Flow Rate	GPM (l/m)	22.1 (83.7)	25.9 (98.0)	30.3 (114.7)	27.3 (103.3)	32.5 (123.0)	38.8 (146.9)	32.0 (121.1)	38.5 (145.7)	46.7 (176.8)	40.6 (153.7)	48.4 (183.2)	57.8 (218.8)	47.5 (179.8)	57.3 (216.9)	69.7 (263.8)
	Coil Fluid PD	FT WG (kPa)	8.1 (24.2)	7.1 (21.2)	11.4 (34.1)	7.1 (21.2)	10.9 (32.6)	14.2 (42.4)	9.6 (28.7)	11.2 (33.5)	20.0 (59.8)	7.3 (21.8)	10.9 (32.6)	12.4 (37.1)	9.8 (29.3)	9.3 (27.8)	17.5 (52.0)
ΔT = 12°F 45° EWT 57° F LWT	Net Total	MBH (kW)	101.4 (29.7)	120.5 (35.3)	143.1 (41.9)	124.8 (36.6)	150.3 (44.0)	182.1 (53.4)	145.9 (42.8)	177.3 (52.0)	218.0 (63.9)	185.2 (54.3)	223.6 (65.5)	271.5 (79.6)	216.5 (63.4)	263.4 (77.2)	324.9 (95.2)
	Net Sensible	MBH (kW)	93.3 (27.3)	103.5 (30.3)	114.4 (33.5)	118.6 (34.8)	132.6 (38.9)	148.1 (43.4)	142.4 (41.7)	160.1 (46.9)	180.2 (52.8)	176.9 (51.8)	198.0 (58.0)	221.4 (64.9)	212.4 (62.2)	239.0 (70.0)	269.3 (78.9)
	Flow Rate	GPM (l/m)	17.3 (65.5)	20.5 (77.6)	24.3 (92.0)	21.3 (80.6)	25.6 (96.6)	31.0 (117.3)	25.0 (94.6)	30.3 (114.7)	37.3 (141.2)	31.6 (119.6)	38.1 (144.2)	46.2 (174.9)	37.1 (140.4)	45.0 (170.3)	55.6 (210.5)
	Coil Fluid PD	FT WG (kPa)	5.0 (14.9)	7.5 (22.4)	7.5 (22.4)	7.5 (22.4)	6.9 (20.6)	11.9 (35.6)	6.0 (17.9)	9.5 (28.4)	13.2 (39.5)	7.1 (21.2)	6.9 (20.6)	11.9 (35.6)	6.1 (18.2)	9.5 (28.4)	11.5 (34.4)
ΔT = 14°F 45° EWT 59° F LWT	Net Total	MBH (kW)	94.7 (27.8)	113.8 (33.4)	137.2 (40.2)	116.8 (34.2)	141.7 (41.5)	174.0 (51.0)	136.6 (40.0)	167.1 (49.0)	208.0 (61.0)	173.3 (50.8)	210.7 (61.8)	259.4 (76.0)	202.6 (59.4)	248.3 (72.8)	309.9 (90.8)
	Net Sensible	MBH (kW)	90.6 (26.6)	100.7 (29.5)	111.8 (32.8)	115.4 (34.8)	129.1 (37.8)	144.6 (42.4)	136.6 (40.0)	156.0 (45.7)	176.0 (51.6)	172.2 (50.5)	192.7 (56.5)	216.2 (63.4)	202.6 (59.4)	232.9 (68.3)	263.0 (77.1)
	Flow Rate	GPM (l/m)	13.8 (52.2)	16.6 (62.0)	20.0 (75.7)	17.1 (64.7)	20.7 (78.4)	25.4 (96.2)	20.4 (76.9)	24.5 (92.7)	30.5 (115.5)	25.4 (96.1)	30.8 (116.6)	37.9 (143.5)	29.8 (112.8)	36.4 (137.8)	45.5 (172.2)
	Coil Fluid PD	FT WG (kPa)	3.2 (9.6)	5.0 (14.9)	8.0 (23.9)	4.9 (14.6)	7.6 (22.7)	8.1 (24.2)	6.7 (20.0)	6.4 (19.1)	11.5 (34.4)	4.6 (13.7)	7.1 (21.2)	8.2 (24.5)	6.3 (18.8)	6.3 (18.8)	11.6 (34.7)
80°F DB / 64.2°F WB, 42% RH, (26.7°C DB / 17.9°C WB), 55°F DP																	
ΔT = 10°F 45° EWT 55° F LWT	Net Total	MBH (kW)	93.0 (27.3)	110.6 (32.4)	131.1 (38.4)	114.1 (33.4)	137.7 (40.4)	166.7 (48.9)	132.9 (38.9)	162.0 (47.5)	199.4 (58.4)	169.2 (49.6)	204.7 (60.0)	248.6 (72.9)	197.0 (57.7)	240.7 (70.5)	297.1 (87.1)
	Net Sensible	MBH (kW)	81.3 (23.8)	90.5 (26.5)	100.5 (29.5)	103.0 (30.2)	115.7 (33.9)	129.9 (38.1)	123.2 (36.1)	139.3 (40.8)	157.7 (46.2)	153.5 (45.0)	172.7 (50.6)	194.2 (56.9)	183.7 (53.8)	207.8 (60.9)	235.5 (69.0)
	Flow Rate	GPM (l/m)	19.0 (71.9)	22.5 (85.2)	26.7 (101.1)	23.4 (88.6)	28.2 (106.7)	34.1 (129.1)	27.4 (103.7)	33.3 (126.1)	41.0 (155.2)	34.7 (131.4)	41.9 (158.6)	50.9 (192.7)	40.6 (153.7)	49.5 (187.4)	61.1 (231.3)
	Coil Fluid PD	FT WG (kPa)	6.0 (17.9)	8.9 (26.6)	9.0 (26.9)	5.3 (15.3)	10.9 (32.6)	14.2 (42.4)	7.1 (21.2)	11.4 (34.1)	17.5 (46.9)	8.5 (25.4)	8.3 (24.8)	9.8 (29.3)	7.3 (21.8)	11.4 (34.1)	13.7 (40.9)
ΔT = 12°F 45° EWT 57° F LWT	Net Total	MBH (kW)	85.6 (25.1)	103.3 (30.3)	124.8 (36.6)	105.0 (30.8)	128.2 (37.6)	158.1 (46.3)	122.5 (35.9)	150.6 (44.1)	188.7 (55.3)	155.8 (45.7)	190.6 (55.9)	235.6 (69.0)	181.4 (53.2)	223.8 (65.6)	280.8 (82.3)
	Net Sensible	MBH (kW)	78.3 (22.9)	87.5 (26.6)	97.7 (28.6)	99.3 (29.1)	111.8 (32.8)	126.1 (37.2)	119.1 (34.9)	134.6 (39.4)	153.0 (44.8)	148.1 (43.4)	166.9 (48.9)	188.4 (55.2)	177.4 (52.0)	200.9 (58.4)	228.5 (67.0)
	Flow Rate	GPM (l/m)	14.6 (55.3)	17.6 (66.6)	21.2 (80.3)	18.0 (68.2)	21.9 (82.9)	27.0 (102.0)	21.1 (79.9)	25.8 (97.7)	32.4 (122.6)	26.7 (101.1)	32.6 (123.4)	40.2 (152.2)	31.2 (118.1)	38.0 (145.9)	48.2 (182.5)
	Coil Fluid PD	FT WG (kPa)	3.6 (10.8)	5.5 (16.4)	8.9 (26.6)	5.4 (16.1)	8.5 (25.4)	9.2 (27.5)	7.4 (22.1)	7.0 (20.9)	12.9 (38.6)	5.1 (15.2)	7.9 (23.6)	9.2 (27.5)	6.9 (20.6)	7.0 (20.9)	12.9 (38.6)
ΔT = 14°F 45° EWT 59° F LWT	Net Total	MBH (kW)	79.0 (23.2)	96.3 (28.2)	118.3 (34.7)	97.0 (28.4)	119.4 (35.0)	149.4 (43.8)	112.9 (33.1)	140.4 (41.1)	177.9 (52.1)	143.5 (42.1)	177.3 (52.0)	222.5 (65.2)	167.2 (49.0)	208.3 (61.0)	267.7 (77.6)
	Net Sensible	MBH (kW)	75.6 (22.4)	84.6 (24.8)	94.8 (27.8)	96.1 (28.1)	108.2 (31.7)	122.4 (35.9)	112.9 (33.1)	130.5 (38.2)	148.5 (43.5)	143.2 (42.0)	161.4 (47.3)	202.8 (60.5)	167.2 (49.0)	194.7 (57.1)	221.8 (65.0)
	Flow Rate	GPM (l/m)	11.6 (43.9)	14.1 (53.4)	17.3 (65.5)	14.3 (54.1)	17.5 (66.2)	21.9 (82.9)	16.7 (63.2)	20.7 (78.4)	26.2 (99.2)	21.1 (79.9)	26.0 (98.4)	32.6 (123.4)	24.7 (93.5)	30.7 (116.2)	39.0 (147.6)
	Coil Fluid PD	FT WG (kPa)	2.3 (6.9)	3.6 (10.8)	6.0 (17.9)	3.5 (10.5)	5.5 (16.4)	9.5 (28.4)	4.7 (14.0)	7.6 (22.7)	8.6 (25.7)	6.3 (18.8)	5.1 (15.2)	9.0 (26.9)	4.4 (13.2)	7.0 (20.9)	8.6 (25.7)
75°F DB / 62.5°F WB, 50% RH, (23.9°C DB / 16.9°C WB), 55°F DP																	
ΔT = 10°F 45° EWT 55° F LWT	Net Total	MBH (kW)	77.5 (22.7)	93.8 (27.5)	113.5 (33.3)	94.6 (27.7)	116.2 (34.1)	143.6 (42.1)	109.5 (32.1)	136.0 (39.9)	170.9 (50.1)	140.1 (41.1)	172.4 (50.5)	213.8 (62.7)	162.2 (47.5)	201.8 (59.1)	254.3 (74.5)
	Net Sensible	MBH (kW)	66.2 (19.4)	74.5 (21.8)	83.8 (24.6)	83.5 (24.5)	94.8 (27.5)	107.8 (31.6)	99.5 (29.2)	113.6 (33.5)	130.3 (38.2)	124.4 (36.5)	141.3 (41.4)	161.0 (47.2)	148.3 (43.5)	169.4 (49.6)	194.4 (57.0)
	Flow Rate	GPM (l/m)	15.9 (60.2)	19.2 (72.7)	23.2 (87.8)	19.5 (73.8)	23.9 (90.5)	29.5 (111.7)	22.7 (85.9)	28.1 (106.4)	35.3 (133.6)	28.9 (109.4)	35.4 (134.0)	43.9 (166.2)	33.6 (127.2)	41.7 (157.9)	52.5 (198.7)
	Coil Fluid PD	FT WG (kPa)	4.3 (12.9)	6.6 (19.7)	6.9 (20.6)	6.4 (19.1)	6.1 (18.2)	10.8 (32.3)	8.5 (25.4)	8.3 (24.8)	11.9 (35.6)	6.0 (17.9)	6.0 (17.9)	10.8 (32.3)	8.0 (23.9)	8.2 (24.5)	10.4 (31.1)
ΔT = 12°F 45° EWT 57° F LWT	Net Total	MBH (kW)	69.9 (20.5)	85.9 (25.2)	106.2 (31.1)	85.2 (25.0)	106.0 (31.1)	133.8 (39.2)	98.7 (28.9)	124.0 (36.3)	158.9 (46.6)	126.0 (36.9)	157.3 (46.1)	199.3 (58.4)	146.0 (42.8)	184.0 (53.9)	236.4 (69.3)
	Net Sensible	MBH (kW)	63.0 (18.5)	71.1 (20.8)	80.6 (23.6)	79.7 (23.4)	90.6 (26.6)	103.5 (30.3)	95.2 (27.9)	108.8 (31.9)	125.2 (36.7)	118.7 (34.8)	135.0 (39.6)	156.4 (45.1)	141.8 (41.6)	162.2 (47.5)	186.5 (54.7)
	Flow Rate	GPM (l/m)	12.0 (45.4)	14.7 (55.6)	18.1 (68.5)	14.7 (55.6)	18.2 (68.9)	22.9 (86.7)	17.1 (64.7)	21.4 (81.0)	27.4 (103.7)	21.7 (82.1)	27.0 (102.2)	34.2 (129.5)	25.3 (95.8)	31.8 (120.4)	40.4 (154.4)
	Coil Fluid PD	FT WG (kPa)	2.5 (7.5)	3.9 (11.7)	6.6 (19.7)	3.7 (11.1)	5.9 (17.6)	10.4 (31.1)	4.9 (14.6)	8.1 (24.2)	9.4 (28.1)	6.7 (20.0)	5.5 (16.4)	9.8 (29.3)	4.6 (13.7)	7.5 (22.4)	9.4 (28.1)
ΔT = 14°F 45° EWT 59° F LWT	Net Total	MBH (kW)	42.8 (12.5)	78.3 (22.9)	98.9 (29.0)	76.8 (22.5)	96.7 (28.3)	124.2 (36.4)	89.1 (26.1)	113.1 (33.1)	147.1 (43.1)	113.4 (33.2)	143.2 (42.0)	184.4 (54.0)	131.5 (38.5)	167.3 (49.0)	218.6 (64.1)
	Net Sensible	MBH (kW)	42.8 (12.5)	68.0 (19.9)	77.4 (22.7)	76.4 (22.4)	86.8 (25.4)	99.5 (29.2)	89.1 (26.1)	104.4 (30.6)	120.3 (35.3)	113.4 (33.2)	129.3 (37.3)	148.4 (43.6)	131.5 (38.5)	155.4 (45.5)	179.4 (52.6)
	Flow Rate	GPM (l/m)	6.4 (24.2)	11.5 (43.5)	14.5 (54.9)	11.4 (43.2)	14.3 (54.1)	18.3 (69.3)	13.3 (50.3)	16.8 (63.6)	21.8 (82.5)	16.8 (63.6)	21.1 (79.9)	27.1 (102.6)	19.6 (74.2)	24.8 (93.9)	32.4 (122.6)
	Coil Fluid PD	FT WG (kPa)	0.7 (2.1)	2.4 (7.2)	4.3 (12.9)	2.2 (6.6)	3.7 (11.1)	6.7 (20.0)	3.0 (9.0)	5.1 (15.2)	9.4 (28.1)	4.0 (12.0)	6.5 (19.4)	6.3 (18.8)	5.5 (16.4)	4.6 (13.7)	8.9 (26.6)
85°F DB / 64.5°F WB, 32% RH, (29.4°C DB / 18°C WB), 52°F DP																	
ΔT = 10°F 45° EWT 55° F LWT	Net Total	MBH (kW)	101.5 (29.7)	117.9 (34.6)	136.4 (40.0)	126.2 (37.0)	148.4 (43.5)	174.8 (51.2)	148.7 (43.6)	176.3 (51.7)	210.5 (61.7)	187.7 (55.0)	221.1 (64.8)	260.9 (76.5)	221.2 (64.8)	262.5 (76.9)	314.1 (92.1)
	Net Sensible	MBH (kW)	98.9 (29.0)	108.3 (31.7)	117.9 (34.6)	126.2 (37.0)	139.5 (40.9)	153.4 (45.0)	148.7 (43.6)	169.2 (49.6)	187.4 (54.9)	187.7 (55.0)	208.5 (61.1)	229.4 (67.2)	221.2 (64.8)	252.7 (74.1)	280.2 (82.1)
	Flow Rate	GPM (l/m)	20.7 (78.4)	24.0 (90.7)	27.8 (105.2)	25.8 (97.7)	30.3 (114.7)	35.7 (135.1)	30.5 (115.5)	36.1 (136.7)	42.3 (163.5)	38.4 (145.4)	45.2 (171.1)	54.3 (201.8)	45.4 (171.9)	53.8 (203.7)	64.5 (244.2)
	Coil Fluid PD	FT WG (kPa)	7.1 (21.2)	6.1 (18.2)	9.7 (29.0)	6.3 (18.8)	9.6 (28.7)	12.1 (36.2)	8.8 (26.3)	9.9 (29.6)	17.3 (51.7)	6.5 (19.4)	9.6 (28.7)	10.6 (31.7)	9.0 (26.9)	8.3 (24.8)	15.1 (45.1)
ΔT = 12°F 45° EWT 57° F LWT	Net Total	MBH (kW)	96.1 (28.2)	112.5 (33.0)	131.8 (38.6)	119.4 (35.0)	141.4 (41.4)	168.5 (49.4)	140.8 (41.3)	167.9 (49.2)	202.7 (59.4)	177.5 (52.0)	210.6 (61.7)	251.4 (73.7)	209.3 (61.3)	249.9 (73.2)	302.2 (88.6)
	Net Sensible	MBH (kW)	96.1 (28.2)	105.9 (31.0)	115.8 (33.9)	119.4 (35.0)	136.4 (40.0)	150.6 (44.1)	140.8 (41.3)	165.7 (48.0)	183.9 (53.9)	177.5 (52.0)	204.1 (59.8)	225.2 (66.1)	209.3 (61.3)	245.5 (72.5)	275.0 (80.6)
	Flow Rate	GPM (l/m)	16.4 (62.1)	19.1 (72.3)	22.4 (84.8)	20.4 (77.2)	24.1 (91.2)	28.7 (108.6)	24.1 (91.2)	28.7 (108.6)	34.7 (131.4)	30.3 (114.7)	35.9 (135.9)	42.8 (162.0)	35.9 (135.9)	42.7 (161.6)	51.7 (195.7)

Cooling Capacity Data - Upflow MCC-UF (63-105kW, 18-30T, 45°F EWT)

UPFLOW - 45°F EWT (0% Glycol), Chilled Water Coil Cooling Capacities (63-105kW, 18-30T MCC-UF)

Chilled Water Design ΔT	Coil Size & Cabinet		MC2-C (63-70kW, 18-20 Tons)						MC2-D (88kW, 25.0 Tons)						MC2-E (97-105kW, 27.5-30.0 Tons)					
	Model		MCC-063X-_*-UF			MCC-070X-_*-UF			MCC-088X-_*-UF			MCC-097X-_*-UF			MCC-105X-_*-UF					
	Nominal Capacity		63kW (18 Tons)			70kW (20 Tons)			88kW (25 Tons)			97kW (27.5 Tons)			105kW (30 Tons)					
	Supply Air CFM (CMH)		9,000 (15,291)			10,000 (16,990)			12,500 (21,238)			13,750 (21,361)			15,000 (25,485)					
CW Coil Rows		3		4		6		3		4		6		3		4		6		
Net Cooling Capacity MBH (kW)																				
85°F DB / 65.9°F WB, 36% RH, (29.4°C DB / 18.8°C WB), 55°F DP																				
ΔT = 10°F 45°EWT 55°F LWT	Net Total	MBH (kW)	263.7 (77.3)	321.4 (94.2)	396.1 (116.1)	283.2 (83.0)	346.3 (101.5)	429.7 (125.9)	356.8 (104.6)	434.7 (127.4)	537.3 (157.5)	364.8 (106.9)	449.9 (131.9)	566.9 (166.1)	386.0 (113.1)	477.1 (139.8)	604.4 (177.1)			
	Net Sensible	MBH (kW)	255.4 (74.9)	288.2 (84.5)	325.3 (95.3)	277.8 (81.4)	314.3 (92.1)	356.0 (104.3)	346.7 (101.6)	392.2 (114.9)	444.1 (130.2)	364.8 (106.9)	418.8 (122.7)	478.7 (140.3)	386.0 (113.1)	449.1 (131.6)	514.9 (150.9)			
	Flow Rate	GPM (l/m)	54.2 (205.2)	66.0 (249.8)	81.4 (308.1)	58.4 (221.1)	71.3 (269.9)	88.5 (335.0)	73.6 (278.6)	89.6 (339.2)	110.9 (419.8)	75.2 (284.7)	92.6 (350.5)	116.7 (441.8)	79.8 (302.1)	98.4 (372.5)	124.8 (472.4)			
	Coil Fluid PD	FT WG (kPa)	5.1 (15.2)	8.3 (24.8)	14.8 (44.2)	5.9 (17.6)	9.6 (28.1)	13.5 (40.4)	9.7 (29.0)	11.9 (35.6)	22.4 (67.0)	7.6 (22.7)	8.1 (24.2)	15.2 (45.4)	8.6 (25.7)	9.1 (27.2)	17.3 (51.7)			
ΔT = 12°F 45°EWT 57°F LWT	Net Total	MBH (kW)	245.5 (71.9)	301.8 (88.4)	377.2 (110.5)	263.8 (77.3)	325.1 (95.3)	409.0 (119.9)	333.7 (97.8)	409.5 (120.0)	512.5 (150.2)	340.1 (99.7)	422.5 (123.8)	538.7 (157.9)	360.0 (105.5)	448.2 (131.4)	574.2 (168.3)			
	Net Sensible	MBH (kW)	245.5 (71.9)	280.2 (82.1)	317.3 (93.0)	263.8 (77.3)	305.7 (89.6)	347.3 (101.8)	333.7 (97.8)	382.1 (112.0)	433.7 (127.1)	340.1 (99.7)	407.9 (119.5)	467.1 (136.9)	360.0 (105.5)	437.7 (128.3)	502.4 (147.2)			
	Flow Rate	GPM (l/m)	42.1 (159.4)	51.7 (195.7)	64.6 (244.5)	45.4 (171.9)	55.8 (211.9)	70.3 (266.1)	57.5 (217.7)	70.4 (266.5)	88.2 (333.9)	58.5 (221.4)	72.6 (274.8)	92.5 (350.2)	62.1 (235.1)	77.2 (292.2)	98.9 (374.4)			
	Coil Fluid PD	FT WG (kPa)	6.3 (18.8)	5.2 (15.5)	9.6 (28.1)	7.8 (21.8)	6.0 (17.9)	11.2 (33.5)	6.0 (17.9)	10.0 (29.9)	14.6 (43.6)	4.7 (14.0)	7.7 (23.0)	9.8 (35.9)	5.3 (15.8)	8.6 (25.7)	11.1 (33.2)			
ΔT = 14°F 45°EWT 59°F LWT	Net Total	MBH (kW)	229.2 (67.2)	283.6 (83.1)	358.6 (105.1)	246.2 (72.2)	305.5 (89.5)	388.7 (113.9)	312.5 (91.6)	386.1 (113.2)	488.2 (143.1)	317.5 (93.1)	397.3 (116.4)	511.7 (150.0)	336.3 (98.6)	421.5 (123.5)	545.2 (159.8)			
	Net Sensible	MBH (kW)	229.2 (67.2)	273.0 (80.0)	309.6 (90.7)	246.2 (72.2)	297.9 (87.3)	338.9 (99.3)	312.5 (91.6)	372.8 (109.3)	423.7 (124.2)	317.5 (93.1)	397.3 (116.4)	456.0 (133.6)	336.3 (98.6)	421.5 (123.5)	490.7 (143.8)			
	Flow Rate	GPM (l/m)	33.8 (127.9)	41.7 (157.9)	52.7 (199.5)	36.4 (137.0)	45.3 (170.9)	57.3 (216.9)	46.3 (174.9)	59.0 (225.7)	76.1 (282.9)	46.9 (177.5)	58.6 (221.6)	49.8 (188.5)	49.8 (188.5)	62.3 (236.8)	80.6 (305.1)			
	Coil Fluid PD	FT WG (kPa)	7.1 (21.2)	6.5 (19.4)	6.5 (19.4)	4.7 (14.0)	7.6 (22.7)	7.6 (22.7)	7.7 (23.0)	6.7 (20.0)	12.6 (37.7)	6.9 (20.6)	5.1 (15.2)	9.5 (28.4)	7.8 (23.3)	5.7 (17.0)	10.7 (32.0)			
80°F DB / 64.2°F WB, 42% RH, (26.7°C DB / 17.9°C WB), 55°F DP																				
ΔT = 10°F 45°EWT 55°F LWT	Net Total	MBH (kW)	222.8 (65.3)	275.2 (80.7)	344.8 (101.1)	238.6 (69.9)	296.0 (86.7)	373.5 (109.5)	302.0 (88.5)	372.7 (109.2)	467.7 (137.1)	306.8 (89.9)	383.6 (112.4)	491.4 (144.0)	324.1 (95.0)	406.2 (119.0)	523.0 (153.3)			
	Net Sensible	MBH (kW)	214.1 (62.7)	243.1 (71.2)	277.0 (81.2)	232.6 (68.2)	264.8 (77.6)	302.7 (88.7)	290.7 (85.2)	330.9 (97.0)	377.8 (110.7)	306.8 (89.9)	352.4 (103.3)	406.5 (119.1)	324.1 (95.0)	377.6 (110.7)	436.6 (128.0)			
	Flow Rate	GPM (l/m)	46.0 (174.1)	56.7 (214.6)	71.1 (269.1)	49.4 (187.0)	61.2 (231.7)	77.3 (292.6)	62.6 (231.0)	77.2 (292.2)	97.0 (367.2)	63.6 (240.8)	79.3 (300.2)	101.6 (384.6)	67.4 (255.1)	84.3 (319.1)	108.5 (410.7)			
	Coil Fluid PD	FT WG (kPa)	7.5 (22.4)	6.2 (18.5)	11.5 (34.4)	8.6 (25.7)	7.2 (21.5)	13.4 (40.1)	7.1 (21.7)	11.9 (35.6)	17.5 (52.3)	5.5 (16.4)	9.1 (27.2)	11.7 (35.0)	6.2 (18.5)	10.2 (30.5)	13.3 (39.8)			
ΔT = 12°F 45°EWT 57°F LWT	Net Total	MBH (kW)	204.4 (59.9)	255.0 (74.7)	324.5 (95.1)	219.0 (64.2)	274.1 (80.3)	351.2 (102.9)	278.5 (81.6)	346.5 (101.5)	441.1 (129.3)	281.8 (82.6)	355.4 (104.2)	461.5 (135.3)	297.9 (87.3)	376.4 (110.3)	491.2 (144.0)			
	Net Sensible	MBH (kW)	204.4 (59.9)	235.0 (68.9)	268.5 (78.7)	219.0 (64.2)	256.0 (75.0)	293.4 (86.0)	278.5 (81.6)	320.4 (93.9)	366.7 (107.5)	281.8 (82.6)	341.2 (100.0)	394.1 (115.5)	297.9 (87.3)	365.8 (107.2)	423.5 (124.1)			
	Flow Rate	GPM (l/m)	35.3 (133.6)	43.9 (166.2)	55.8 (211.2)	37.9 (143.5)	47.3 (179.0)	60.6 (229.4)	48.3 (182.6)	63.2 (238.8)	76.3 (288.8)	48.8 (184.7)	61.4 (232.4)	79.6 (301.3)	51.8 (196.1)	62.3 (236.8)	80.6 (305.1)			
	Coil Fluid PD	FT WG (kPa)	4.5 (13.5)	7.2 (21.5)	7.3 (21.8)	5.1 (15.2)	8.3 (24.8)	8.5 (25.4)	8.4 (25.1)	7.3 (21.8)	14.0 (41.8)	7.5 (22.4)	5.6 (16.7)	10.5 (31.4)	3.7 (11.1)	6.2 (18.5)	11.9 (35.6)			
ΔT = 14°F 45°EWT 59°F LWT	Net Total	MBH (kW)	187.6 (55.0)	236.2 (69.2)	304.8 (89.3)	201.1 (58.9)	254.1 (74.5)	329.8 (96.7)	257.0 (75.3)	322.2 (94.1)	415.3 (121.7)	259.1 (75.9)	329.5 (96.6)	432.9 (126.9)	273.8 (80.2)	348.9 (102.3)	460.6 (135.0)			
	Net Sensible	MBH (kW)	187.6 (55.0)	226.7 (66.7)	260.3 (76.3)	201.1 (58.9)	248.1 (72.7)	284.6 (83.4)	257.0 (75.3)	310.8 (91.1)	356.1 (104.4)	259.1 (75.9)	329.5 (96.6)	382.4 (112.9)	273.8 (80.2)	348.9 (102.3)	411.1 (120.5)			
	Flow Rate	GPM (l/m)	27.8 (105.2)	34.9 (132.1)	45.0 (170.3)	29.9 (113.2)	37.7 (142.7)	48.9 (185.1)	38.3 (145.0)	47.8 (180.9)	61.7 (233.6)	38.6 (146.1)	48.9 (185.1)	64.1 (242.6)	40.9 (154.8)	51.9 (196.5)	68.5 (259.3)			
	Coil Fluid PD	FT WG (kPa)	4.8 (14.3)	7.8 (23.3)	8.4 (25.1)	5.6 (16.7)	5.4 (16.1)	9.9 (29.6)	5.4 (16.1)	8.8 (26.3)	9.4 (28.1)	4.7 (14.0)	7.8 (23.3)	6.9 (20.6)	5.3 (15.8)	4.0 (12.0)	7.9 (23.6)			
75°F DB / 62.5°F WB, 50% RH, (23.9°C DB / 16.9°C WB), 55°F DP																				
ΔT = 10°F 45°EWT 55°F LWT	Net Total	MBH (kW)	181.8 (53.3)	229.0 (67.1)	293.5 (86.0)	194.3 (56.9)	245.6 (72.0)	317.1 (92.9)	247.2 (72.4)	310.4 (91.0)	398.0 (116.6)	249.0 (73.0)	317.3 (93.0)	415.9 (121.9)	262.2 (76.8)	335.2 (98.2)	441.6 (129.4)			
	Net Sensible	MBH (kW)	172.0 (50.4)	197.4 (57.9)	227.9 (66.8)	186.7 (54.7)	214.5 (62.9)	248.5 (72.8)	233.8 (68.5)	268.5 (78.7)	310.4 (91.0)	246.6 (72.3)	285.0 (83.5)	332.9 (97.6)	262.2 (76.8)	304.8 (89.3)	356.8 (104.6)			
	Flow Rate	GPM (l/m)	37.8 (143.1)	47.5 (179.8)	60.8 (230.2)	40.6 (153.7)	51.1 (193.4)	66.0 (249.8)	51.7 (195.7)	64.7 (244.9)	80.3 (314.2)	52.1 (197.2)	66.1 (250.2)	85.6 (327.4)	55.0 (208.2)	70.1 (265.4)	92.2 (349.0)			
	Coil Fluid PD	FT WG (kPa)	5.1 (15.2)	8.4 (25.1)	8.5 (25.4)	5.9 (17.6)	5.1 (15.2)	10.0 (29.9)	4.9 (14.6)	8.5 (25.4)	16.4 (49.0)	3.7 (11.1)	6.4 (19.1)	12.3 (36.8)	4.2 (12.6)	7.2 (21.5)	9.8 (29.3)			
ΔT = 12°F 45°EWT 57°F LWT	Net Total	MBH (kW)	163.0 (47.8)	207.0 (60.0)	271.5 (79.6)	174.0 (51.0)	222.6 (65.2)	292.8 (85.8)	222.8 (65.3)	282.9 (82.9)	368.9 (108.1)	223.0 (65.4)	287.7 (84.3)	383.4 (112.4)	235.2 (68.9)	303.9 (89.1)	407.0 (119.3)			
	Net Sensible	MBH (kW)	163.0 (47.8)	188.7 (55.3)	218.7 (64.1)	174.0 (51.0)	205.6 (60.2)	238.4 (69.2)	222.8 (65.3)	257.4 (75.4)	298.3 (87.4)	223.0 (65.4)	273.0 (82.1)	319.6 (93.7)	235.2 (68.9)	292.4 (85.7)	372.0 (100.4)			
	Flow Rate	GPM (l/m)	28.4 (107.5)	36.0 (136.3)	47.0 (177.9)	30.4 (115.1)	38.7 (146.5)	50.9 (192.7)	39.0 (147.6)	49.3 (186.6)	64.3 (243.4)	39.0 (147.6)	50.1 (189.6)	66.6 (252.1)	41.3 (156.3)	53.1 (201.0)	71.0 (268.8)			
	Coil Fluid PD	FT WG (kPa)	5.0 (14.9)	4.9 (14.6)	9.1 (27.2)	5.8 (17.3)	5.6 (16.7)	6.1 (18.2)	5.6 (16.7)	9.3 (27.8)	10.2 (30.5)	4.8 (14.3)	3.8 (11.4)	7.5 (22.4)	5.4 (16.1)	4.2 (12.6)	8.4 (25.1)			
ΔT = 14°F 45°EWT 59°F LWT	Net Total	MBH (kW)	145.7 (42.7)	188.0 (55.1)	250.0 (73.3)	155.7 (45.6)	201.7 (59.1)	269.6 (79.0)	200.6 (58.8)	257.5 (75.5)	340.6 (99.8)	199.8 (58.6)	260.5 (76.3)	352.8 (103.4)	210.8 (61.8)	275.3 (80.7)	374.1 (109.6)			
	Net Sensible	MBH (kW)	145.7 (42.7)	180.0 (53.0)	209.8 (61.5)	155.7 (45.6)	197.0 (57.7)	228.9 (67.1)	200.6 (58.8)	247.2 (72.5)	286.8 (84.1)	199.8 (58.6)	260.5 (76.3)	307.1 (90.0)	210.8 (61.8)	275.3 (80.7)	329.4 (96.5)			
	Flow Rate	GPM (l/m)	21.8 (82.5)	28.0 (106.0)	37.2 (140.8)	23.4 (88.6)	30.2 (114.3)	40.3 (152.6)	30.2 (114.3)	38.6 (146.1)	51.0 (193.1)	30.1 (113.9)	39.0 (147.6)	52.7 (199.5)	31.9 (120.8)	41.4 (156.7)	56.1 (212.4)			
	Coil Fluid PD	FT WG (kPa)	6.3 (18.8)	5.1 (15.2)	5.8 (17.3)	3.4 (10.2)	5.9 (17.6)	6.8 (20.3)	5.8 (17.3)	5.8 (17.3)	6.6 (19.7)	5.3 (15.8)	5.0 (14.9)	4.8 (14.3)	5.9 (17.6)	5.6 (16.7)	5.4 (16.1)			
85°F DB / 64.5°F WB, 32% RH, (29.4°C DB / 18°C WB), 55°F DP																				
ΔT = 10°F 45°EWT 55°F LWT	Net Total	MBH (kW)	253.9 (74.4)	303.5 (88.9)	367.1 (107.6)	273.8 (80.2)	328.3 (96.2)	399.4 (117.1)	344.2 (100.9)	411.6 (120.6)	499.2 (146.3)	355.7 (104.2)	429.6 (125.9)	529.4 (155.2)	376.7 (110.4)	457.4 (134.1)	566.0 (165.9)			
	Net Sensible	MBH (kW)	253.9 (74.4)	297.7 (87.2)	331.4 (97.1)	273.8 (80.2)	325.6 (95.4)	363.5 (106.5)	344.2 (100.9)	406.1 (119.0)	453.4 (132.9)	355.7 (104.2)	429.6 (125.9)	509.5 (148.8)	376.7 (110.4)	457.4 (134.1)	528.7 (154.9)			
	Flow Rate	GPM (l/m)	52.2 (197.6)	62.3 (235.8)	75.4 (285.4)	56.4 (213.5)	67.6 (255.9)	82.4 (311.9)	71.0 (268.9)	84.8 (321.0)	103.1 (390.3)	73.3 (277.5)	88.4 (334.6)	109.0 (412.6)	77.8 (294.5)	94.7 (351.7)	116.9 (442.5)			
	Coil Fluid PD	FT WG (kPa)	4.8 (14.3)	7.5 (22.4)	12.8 (38.3)	5.6 (16.7)	8.7 (26.0)	15.1 (45.1)	9.1 (27.2)	14.2 (42.4)	19.5 (58.3)	7.2 (21.5)	7.4 (22.1)	13.4 (40.1)	8.1 (24.2)	8.4 (25.1)	15.3 (45.7)			
ΔT = 12°F 45°EWT 57°F LWT	Net Total	MBH (kW)	239.5 (70.2)	288.3 (84.5)	352.4 (103.3)	257.3 (75.4)	311.9 (91.4)	383.2 (112.3)	325.8 (95.5)	392.0 (114.9)	479.9 (140.6)	334.9 (98.1)	408.1 (119.6)	507.6 (148.8)	355.9 (104.3)	434.5 (127.3)	542.6 (159.0)			
	Net Sensible	MBH (kW)	239.5 (70.2)	288.3 (84.5)	325.0 (95.2)	257.3 (75.4)	311.9 (91.4)	356.6 (104.5)	325.8 (95.5)	392.0 (114.9)	445.2 (130.5)	334.9 (98.1)	408.1 (119.6)	484.1 (141.1)	355.9 (104.					

Cooling Capacity Data - Downflow MCC-DF (21-53kW, 6-15T, 45°F EWT)

DOWNFLOW - 45°F EWT (0% Glycol), Chilled Water Coil Cooling Capacities (21-53kW, 6-15T MCC-UF)

Chilled Water Design ΔT	Coil Size & Cabinet		MC2-A (21-35kW, 6-10 Tons)						MC2-B (42-53kW, 12-15 Tons)						
	Model		MCC-021X-...-DF		MCC-028X-...-DF		MCC-035X-...-DF		MCC-042X-...-DF			MCC-053X-...-DF			
	Nominal Capacity		21kW (6 Tons)		28kW (8 Tons)		35kW (10 Tons)		42kW (12 Tons)			53kW (15 Tons)			
	Supply Air CFM (CMH)		3,000 (5,097)		4,000 (6,796)		5,000 (8,495)		6,000 (10,194)			7,500 (12,743)			
	Coil Rows		3	4	6	3	4	6	3	4	6	3	4	6	
Net Cooling Capacity MBH (kW)															
85°F DB / 65.9°F WB, 36% RH, (29.4°C DB / 18.8°C WB), 55°F DP															
ΔT = 10°F 45° EWT 55° FWT	Net Total	MBH (kW)	108.9 (31.9)	127.9 (37.5)	149.3 (43.8)	134.2 (39.3)	159.9 (46.9)	190.6 (55.9)	156.9 (46.0)	188.8 (55.3)	228.7 (67.0)	199.4 (58.4)	238.0 (69.8)	284.4 (83.3)	232.8 (68.2)
	Net Sensible	MBH (kW)	96.7 (28.3)	106.9 (31.3)	117.5 (34.4)	122.8 (36.0)	137.0 (40.2)	152.3 (44.6)	147.2 (43.1)	165.3 (48.4)	185.4 (54.3)	183.2 (53.7)	204.5 (59.9)	227.7 (66.7)	219.6 (64.4)
	Flow Rate	GPM (l/m)	22.1 (83.7)	25.9 (98.0)	30.3 (114.7)	27.3 (103.3)	32.5 (123.0)	38.8 (146.9)	32.0 (121.1)	38.5 (145.7)	46.7 (176.8)	40.6 (153.7)	48.4 (183.2)	57.8 (218.8)	47.5 (179.8)
	Coil Fluid PD	FT WG (kPa)	8.1 (24.2)	7.1 (21.2)	11.4 (34.1)	7.1 (21.2)	10.9 (32.6)	14.2 (42.4)	9.6 (28.7)	11.2 (33.5)	20.0 (59.8)	7.3 (21.8)	10.9 (32.6)	12.4 (37.1)	9.8 (29.3)
ΔT = 12°F 45° EWT 57° FWT	Net Total	MBH (kW)	101.9 (29.9)	121.0 (35.5)	143.6 (42.1)	125.4 (36.8)	150.9 (44.2)	182.7 (53.5)	146.7 (43.0)	178.1 (52.2)	218.8 (64.1)	186.2 (54.6)	224.5 (65.8)	272.5 (79.9)	217.7 (63.8)
	Net Sensible	MBH (kW)	93.8 (27.5)	103.9 (30.5)	114.9 (33.7)	119.2 (34.9)	133.2 (39.0)	148.8 (43.6)	143.2 (42.0)	160.9 (47.2)	181.0 (53.0)	177.9 (52.1)	198.9 (58.3)	222.4 (65.2)	213.6 (62.6)
	Flow Rate	GPM (l/m)	17.3 (65.5)	20.5 (77.6)	24.3 (92.0)	21.3 (80.6)	25.6 (96.9)	31.0 (117.3)	25.0 (94.6)	30.3 (114.7)	37.3 (141.2)	31.6 (119.6)	38.1 (144.2)	46.2 (174.9)	37.1 (140.4)
	Coil Fluid PD	FT WG (kPa)	5.0 (14.9)	7.5 (22.4)	7.5 (22.4)	7.5 (22.4)	6.9 (20.6)	11.9 (35.6)	6.0 (17.9)	9.5 (28.4)	13.2 (39.5)	7.1 (21.2)	6.9 (20.6)	11.9 (35.6)	6.1 (18.2)
ΔT = 14°F 45° EWT 59° FWT	Net Total	MBH (kW)	95.2 (27.9)	114.3 (33.5)	137.7 (40.4)	117.4 (34.4)	142.4 (41.7)	174.7 (51.2)	137.4 (40.3)	167.9 (49.2)	208.8 (61.2)	174.3 (51.1)	211.7 (62.0)	260.4 (76.3)	203.8 (59.7)
	Net Sensible	MBH (kW)	91.1 (26.7)	101.1 (29.6)	112.3 (32.9)	116.0 (34.0)	129.7 (38.0)	145.3 (42.6)	137.4 (40.3)	156.8 (46.0)	176.8 (51.8)	173.1 (50.7)	193.7 (56.8)	217.2 (63.7)	203.8 (59.7)
	Flow Rate	GPM (l/m)	13.8 (52.2)	16.6 (62.0)	20.0 (75.7)	17.1 (64.7)	20.7 (78.4)	25.4 (96.2)	21.1 (79.1)	24.5 (92.7)	30.5 (115.5)	25.4 (96.1)	30.8 (116.6)	37.9 (143.5)	29.8 (112.8)
	Coil Fluid PD	FT WG (kPa)	3.2 (9.6)	5.0 (14.9)	8.0 (23.9)	4.9 (14.6)	7.6 (22.7)	8.1 (24.2)	6.7 (20.0)	6.4 (19.1)	11.5 (34.4)	4.6 (13.7)	7.1 (21.2)	8.2 (24.5)	6.3 (18.8)
80°F DB / 64.2°F WB, 42% RH, (26.7°C DB / 17.9°C WB), 55°F DP															
ΔT = 10°F 45° EWT 55° FWT	Net Total	MBH (kW)	93.5 (27.4)	111.1 (32.6)	131.5 (38.5)	114.7 (33.6)	138.4 (40.6)	167.3 (49.0)	133.7 (39.2)	162.8 (47.7)	200.2 (58.7)	170.2 (49.9)	205.7 (60.3)	249.6 (73.2)	198.2 (58.1)
	Net Sensible	MBH (kW)	81.8 (24.0)	91.0 (26.7)	101.0 (29.6)	103.6 (30.4)	116.4 (34.1)	130.5 (38.2)	124.0 (36.3)	140.1 (41.1)	158.5 (46.5)	154.5 (45.3)	173.7 (50.9)	195.1 (57.2)	184.8 (54.2)
	Flow Rate	GPM (l/m)	19.0 (71.9)	22.5 (85.2)	26.7 (101.1)	23.4 (88.6)	28.2 (106.7)	34.1 (129.1)	27.4 (103.7)	33.3 (126.1)	41.0 (155.2)	34.7 (131.4)	41.9 (158.6)	50.9 (192.7)	40.6 (153.7)
	Coil Fluid PD	FT WG (kPa)	6.0 (17.9)	8.9 (26.6)	9.0 (26.9)	5.3 (15.3)	10.2 (30.6)	14.2 (42.4)	7.1 (21.2)	11.4 (34.1)	15.7 (46.9)	8.5 (25.4)	8.3 (24.7)	9.8 (29.3)	7.3 (21.8)
ΔT = 12°F 45° EWT 57° FWT	Net Total	MBH (kW)	86.1 (25.2)	103.8 (30.4)	125.3 (36.7)	105.7 (31.0)	128.9 (37.8)	158.8 (46.5)	123.3 (36.1)	151.4 (44.4)	189.5 (55.5)	156.7 (45.9)	191.6 (56.2)	236.5 (69.3)	182.6 (53.5)
	Net Sensible	MBH (kW)	78.8 (23.1)	87.9 (25.8)	98.2 (28.8)	100.0 (29.3)	112.4 (32.9)	126.7 (37.1)	119.9 (35.1)	135.4 (39.7)	153.8 (45.1)	149.1 (43.7)	167.8 (49.2)	189.3 (55.5)	178.6 (52.3)
	Flow Rate	GPM (l/m)	14.6 (55.3)	17.7 (66.6)	21.2 (80.3)	18.0 (68.1)	21.9 (82.9)	27.0 (102.2)	21.1 (79.9)	25.8 (97.2)	32.4 (122.6)	26.7 (101.1)	32.6 (123.4)	40.2 (152.2)	31.2 (118.1)
	Coil Fluid PD	FT WG (kPa)	3.6 (10.8)	5.5 (16.4)	8.9 (26.6)	5.4 (16.1)	8.5 (25.4)	9.2 (27.5)	7.4 (22.1)	7.0 (20.9)	12.9 (38.6)	5.1 (15.2)	7.9 (23.6)	9.2 (27.5)	6.9 (20.6)
ΔT = 14°F 45° EWT 59° FWT	Net Total	MBH (kW)	79.5 (23.3)	96.8 (28.4)	118.8 (34.8)	97.6 (28.6)	120.0 (35.2)	150.0 (44.0)	113.7 (33.3)	141.2 (41.4)	178.7 (52.4)	144.5 (42.3)	178.2 (52.2)	223.4 (65.5)	168.4 (49.4)
	Net Sensible	MBH (kW)	76.1 (22.3)	85.0 (24.9)	95.3 (27.9)	96.8 (28.4)	108.8 (31.9)	123.0 (36.0)	113.7 (33.3)	131.3 (38.5)	149.3 (43.8)	144.2 (42.3)	162.4 (47.6)	188.4 (54.8)	168.4 (49.4)
	Flow Rate	GPM (l/m)	11.6 (43.9)	14.1 (53.4)	17.3 (65.5)	14.3 (54.1)	17.5 (66.2)	21.9 (82.9)	16.7 (63.2)	20.7 (78.4)	26.2 (99.2)	21.1 (79.9)	26.0 (98.4)	32.6 (123.4)	24.7 (93.5)
	Coil Fluid PD	FT WG (kPa)	2.3 (6.9)	3.6 (10.8)	6.0 (17.9)	3.5 (10.5)	5.5 (16.4)	9.5 (28.4)	4.7 (14.0)	7.6 (22.7)	8.6 (25.7)	6.3 (18.8)	5.1 (15.2)	9.0 (26.9)	4.4 (13.2)
75°F DB / 62.5°F WB, 50% RH, (23.9°C DB / 16.9°C WB), 55°F DP															
ΔT = 10°F 45° EWT 55° FWT	Net Total	MBH (kW)	78.0 (22.9)	94.3 (27.6)	114.0 (33.4)	95.2 (27.9)	116.8 (34.2)	144.2 (42.3)	110.3 (32.3)	136.8 (40.1)	171.7 (50.3)	141.1 (41.4)	173.3 (50.8)	214.8 (63.0)	163.4 (47.9)
	Net Sensible	MBH (kW)	66.6 (19.5)	75.0 (22.0)	84.3 (24.7)	84.1 (24.6)	95.4 (28.4)	108.5 (31.8)	100.3 (29.4)	114.4 (33.5)	131.1 (38.4)	125.3 (36.7)	142.2 (41.7)	162.0 (47.5)	149.4 (43.8)
	Flow Rate	GPM (l/m)	15.9 (60.2)	19.2 (72.7)	23.2 (87.8)	19.5 (73.8)	23.9 (90.5)	29.5 (111.3)	22.7 (85.9)	28.1 (106.4)	35.3 (133.6)	28.9 (109.4)	35.4 (134.0)	43.9 (166.2)	33.6 (127.2)
	Coil Fluid PD	FT WG (kPa)	4.3 (12.9)	6.6 (19.7)	6.9 (20.6)	6.4 (19.1)	6.1 (18.2)	10.8 (32.3)	8.5 (25.4)	8.3 (24.8)	11.9 (35.6)	6.0 (17.9)	6.0 (17.9)	10.8 (32.3)	8.0 (23.9)
ΔT = 12°F 45° EWT 57° FWT	Net Total	MBH (kW)	70.4 (20.6)	86.4 (25.3)	106.7 (31.3)	85.8 (25.1)	106.6 (31.2)	134.4 (39.4)	99.5 (29.2)	124.8 (36.6)	159.7 (46.8)	126.9 (37.2)	158.2 (46.4)	200.3 (58.7)	147.2 (43.1)
	Net Sensible	MBH (kW)	63.5 (18.6)	71.6 (21.0)	81.1 (23.8)	80.3 (23.5)	91.2 (26.7)	104.2 (30.5)	96.0 (28.1)	109.5 (31.2)	126.0 (36.9)	119.7 (35.1)	136.0 (39.9)	155.6 (45.6)	143.0 (41.9)
	Flow Rate	GPM (l/m)	12.0 (45.4)	14.7 (55.6)	18.1 (68.5)	14.7 (55.6)	18.2 (68.9)	22.9 (86.7)	17.1 (64.7)	21.4 (81.0)	27.4 (103.7)	21.7 (82.1)	27.0 (102.2)	34.2 (129.5)	25.3 (95.8)
	Coil Fluid PD	FT WG (kPa)	2.5 (7.5)	3.9 (11.7)	6.6 (19.7)	3.7 (11.1)	5.9 (17.6)	10.4 (31.1)	4.9 (14.6)	8.1 (24.2)	9.4 (28.1)	6.7 (20.0)	5.5 (16.4)	9.8 (29.3)	4.6 (13.7)
ΔT = 14°F 45° EWT 59° FWT	Net Total	MBH (kW)	43.3 (12.7)	78.8 (23.1)	99.4 (29.1)	77.4 (22.7)	97.4 (28.5)	124.8 (36.6)	89.8 (26.3)	113.9 (33.4)	147.9 (43.3)	114.4 (33.5)	144.1 (42.2)	185.4 (54.3)	132.7 (38.9)
	Net Sensible	MBH (kW)	43.3 (12.7)	68.5 (20.1)	77.9 (22.8)	77.0 (22.7)	87.4 (25.6)	100.1 (29.6)	89.8 (26.3)	105.1 (30.8)	121.1 (35.5)	114.4 (33.5)	130.2 (38.2)	149.3 (43.8)	132.7 (38.9)
	Flow Rate	GPM (l/m)	6.4 (24.2)	11.5 (43.5)	14.5 (54.9)	11.4 (43.2)	14.3 (54.1)	18.3 (69.3)	13.3 (50.3)	16.8 (63.6)	21.8 (82.5)	16.8 (63.6)	21.1 (79.9)	27.1 (102.6)	19.6 (74.2)
	Coil Fluid PD	FT WG (kPa)	0.7 (2.1)	2.4 (7.2)	4.3 (12.9)	2.2 (6.6)	3.7 (11.1)	6.7 (20.0)	3.0 (9.0)	5.1 (15.2)	9.4 (28.1)	4.0 (12.0)	6.5 (19.4)	6.3 (18.8)	5.5 (16.4)
85°F DB / 64.5°F WB, 32% RH, (29.4°C DB / 18°C WB), 52°F DP															
ΔT = 10°F 45° EWT 55° FWT	Net Total	MBH (kW)	102.0 (29.9)	118.4 (34.7)	136.9 (40.1)	126.8 (37.2)	149.0 (43.7)	175.4 (51.4)	149.5 (43.8)	177.1 (51.9)	211.3 (61.9)	188.7 (55.3)	222.0 (65.1)	261.9 (76.8)	222.4 (65.2)
	Net Sensible	MBH (kW)	99.3 (29.1)	108.8 (31.9)	118.3 (34.7)	126.8 (37.2)	140.1 (41.1)	154.0 (45.1)	149.5 (43.8)	170.0 (49.8)	188.2 (55.2)	188.7 (55.3)	209.4 (61.4)	230.4 (67.5)	222.4 (65.2)
	Flow Rate	GPM (l/m)	20.7 (78.4)	24.0 (90.8)	27.8 (105.2)	25.8 (97.7)	30.3 (114.7)	35.7 (135.1)	30.5 (115.5)	36.1 (136.7)	43.2 (163.5)	38.4 (145.4)	45.2 (171.1)	53.6 (201.8)	45.4 (171.9)
	Coil Fluid PD	FT WG (kPa)	7.1 (21.2)	6.1 (18.2)	9.7 (29.0)	6.3 (18.8)	9.6 (28.7)	12.1 (36.2)	8.8 (26.3)	9.9 (29.6)	17.3 (51.7)	6.5 (19.4)	9.6 (28.7)	10.6 (31.7)	9.0 (26.9)
ΔT = 12°F 45° EWT 57° FWT	Net Total	MBH (kW)	96.6 (28.3)	112.9 (33.1)	132.3 (38.8)	120.1 (35.2)	142.0 (41.6)	169.1 (49.6)	141.6 (41.5)	168.7 (49.4)	203.5 (59.6)	178.5 (52.3)	211.5 (62.0)	252.3 (73.9)	210.5 (61.7)
	Net Sensible	MBH (kW)	96.6 (28.3)	106.2 (31.2)	116.2 (34.1)	120.1 (35.2)	132.2 (40.2)	151.2 (44.3)	141.6 (41.5)	165.5 (48.8)	184.7 (54.1)	178.5 (52.3)	205.0 (60.1)	226.1 (66.1)	210.5 (61.7)
	Flow Rate	GPM (l/m)	16.4 (62.1)	19.1 (72.3)	22.4 (84.8)	20.4 (77.2)	24.1 (91.2)	28.7 (108.6)	24.1 (91.2)	28.7 (108.6)	34.7 (131.4)	30.3 (114.7)	35.9 (135.9)	42.8 (162.0)	35.9 (135.9)
	Coil Fluid PD	FT WG (kPa)	4.5 (13.5)	6.5 (19.4)	9.9 (29.6)	6.9 (20.6)	6.2 (18.5)	10.3 (30.8)	5.6 (16.7)	6.8 (25.7)	14.7 (43.9)	6.5 (19.4)	6.1 (18.2)	10.3 (30.8)	5.7 (17.0)
ΔT = 14°F 45° EWT 59° FWT	Net Total	MBH (kW)	91.4 (26.8)	107.7 (31.6)	127.6 (37.4)	113.8 (33.4)	135.4 (39.4)	162.9 (47.7)	134.1 (39.3)	160.9 (47.2)	195.8 (57.4)	169.0 (49.5)	201.5 (59.1)	243.0 (71.2)	199.2 (58.4)
	Net Sensible	MBH (kW)	91.4 (26.8)	104.2 (30.5)	114.1 (33.4)	113.8 (33.4)	134.5 (39.4)	148.4 (43.5)	134.1 (39.3)	160.9 (47.2)	181.4 (53.2)	169.0 (49.5)	200.9 (58.9)	222.0 (65.1)	199.2 (58.4)
	Flow Rate	GPM (l/m)	13.3 (50.3)	15.6 (59.1)	18.5 (70.0)	16.6 (62.8)	19.7 (74.6)	23.7 (89.7)	19.6 (74.2)	23.5 (89.0)	28.6 (108.3)	24.6 (93.1)	29.3 (110.9)	35.4 (134.0)	29.1 (110.2)
	Coil Fluid PD	FT WG (kPa)	3.0 (9.0)	4.4 (13.7)	6.9 (20.6)	4.6 (13.7)	6.9 (20.6)	7.2 (21.5)	6.4 (19.1)	5.9 (17.6)	10.2 (30.5)	4.4 (13.2)	6.4 (19.1)	7.2 (21.5)	6.0 (17.9)
80°F DB / 62.9°F WB, 38% RH, (26.7°C DB / 17.2°C WB), 52°F DP															
ΔT = 10°F 45° EWT 55° FWT	Net Total	MBH (kW)	87.4 (25.6)	102.7 (30.1)	120.5 (35.3)	108.2 (31.7)	128.6 (37.7)	153.8 (45.1)							

Cooling Capacity Data - Downflow MCC-DF (63-105kW, 18-30T, 45°F EWT)

DOWNFLOW - 45°F EWT (0% Glycol), Chilled Water Coil Cooling Capacities (63-105kW, 18-30T MCC-DF)

Chilled Water Design ΔT	Coil Size & Cabinet	MC2-C (63-70kW, 18-20 Tons)						MC2-D (88kW, 25.0 Tons)						MC2-E (97-105kW, 27.5-30.0 Tons)					
		Model		MCC-063X-_*-DF		MCC-070X-_*-DF		MCC-088X-_*-DF		MCC-097X-_*-DF		MCC-105X-_*-DF							
		Nominal Capacity		63kW (18 Tons)		70kW (20 Tons)		88kW (25 Tons)		97kW (27.5 Tons)		105kW (30 Tons)							
		Supply Air CFM (CMH)		9,000 (15,291)		10,000 (16,999)		12,500 (21,238)		13,750 (25,361)		15,000 (25,485)							
CW Coil Rows		3	4	6	3	4	6	3	4	6	3	4	6						

Net Cooling Capacity MBH (kW)

85°F DB / 65.9°F WB, 36% RH, (29.4°C DB / 18.8°C WB), 55°F DP																	
ΔT = 10°F 45°EWT 55°F LWT	Net Total	MBH (kW)	265.2 (77.7)	322.9 (94.6)	397.6 (116.5)	284.8 (83.5)	347.9 (102.0)	431.3 (126.4)	358.8 (105.2)	436.7 (128.0)	539.3 (158.1)	367.0 (107.6)	452.1 (132.5)	569.1 (166.8)	388.3 (113.8)	479.5 (140.5)	606.8 (177.8)
	Net Sensible	MBH (kW)	256.8 (75.3)	289.6 (84.9)	326.8 (95.8)	279.4 (81.9)	315.8 (92.6)	357.6 (104.8)	348.7 (102.2)	394.2 (115.5)	446.1 (130.7)	367.0 (107.6)	420.9 (123.4)	480.9 (140.9)	388.3 (113.8)	451.5 (132.3)	517.3 (151.6)
Flow Rate	GPM (l/m)	54.2 (205.2)	66.0 (249.8)	81.4 (308.1)	58.4 (221.1)	71.3 (269.9)	88.5 (335.0)	73.6 (278.6)	89.6 (339.2)	110.9 (419.8)	75.2 (284.7)	92.6 (350.5)	116.7 (441.8)	79.8 (302.1)	98.4 (372.5)	124.8 (472.4)	
Coil Fluid PD	FT WG (kPa)	5.1 (15.2)	8.3 (28.8)	14.8 (44.2)	5.9 (17.6)	9.1 (33.5)	13.5 (40.4)	9.7 (29.0)	11.9 (35.6)	22.4 (67.0)	7.6 (22.7)	8.1 (24.2)	15.2 (45.4)	8.6 (25.7)	9.1 (27.2)	17.3 (51.7)	
ΔT = 12°F 45°EWT 57°F LWT	Net Total	MBH (kW)	246.9 (72.4)	303.2 (88.9)	378.6 (111.0)	265.3 (77.8)	326.7 (95.7)	410.6 (120.3)	335.7 (98.4)	411.5 (120.6)	514.4 (150.8)	342.3 (100.3)	424.7 (124.5)	540.9 (158.5)	362.4 (106.2)	450.6 (132.1)	576.6 (169.0)
	Net Sensible	MBH (kW)	246.9 (72.4)	281.6 (82.5)	318.7 (93.4)	265.3 (77.8)	307.3 (90.1)	348.9 (102.3)	335.7 (98.4)	384.1 (112.6)	435.7 (127.7)	342.3 (100.3)	410.0 (120.2)	469.2 (137.5)	362.4 (106.2)	440.1 (129.0)	504.8 (147.9)
Flow Rate	GPM (l/m)	42.1 (159.4)	51.7 (195.7)	64.6 (244.5)	45.4 (171.9)	55.8 (211.9)	70.3 (266.1)	57.5 (217.7)	70.4 (266.5)	88.2 (333.9)	58.5 (221.4)	72.6 (274.8)	92.5 (350.2)	62.1 (235.1)	77.2 (292.2)	98.9 (374.4)	
Coil Fluid PD	FT WG (kPa)	6.3 (18.8)	5.2 (15.5)	9.6 (28.7)	7.3 (21.8)	8.6 (21.9)	11.0 (33.5)	6.0 (17.9)	10.0 (29.9)	14.6 (43.6)	4.7 (14.0)	7.7 (23.0)	9.8 (35.9)	5.3 (15.8)	8.6 (25.7)	11.1 (33.2)	
ΔT = 14°F 45°EWT 59°F LWT	Net Total	MBH (kW)	230.6 (67.6)	285.0 (83.5)	360.1 (105.5)	247.8 (72.6)	307.1 (90.0)	390.2 (114.4)	314.4 (92.1)	388.1 (113.7)	490.2 (143.7)	319.7 (93.7)	399.5 (117.1)	513.9 (150.6)	338.7 (99.3)	423.8 (124.2)	547.6 (160.5)
	Net Sensible	MBH (kW)	230.6 (67.6)	274.4 (80.4)	311.0 (91.1)	247.8 (72.6)	299.5 (87.8)	340.5 (99.8)	314.4 (92.1)	374.8 (109.8)	425.7 (124.8)	319.7 (93.7)	399.5 (117.1)	458.2 (134.3)	338.7 (99.3)	423.8 (124.2)	493.1 (144.5)
Flow Rate	GPM (l/m)	41.7 (157.9)	41.7 (157.9)	52.7 (199.5)	36.4 (137.8)	45.0 (170.0)	57.3 (216.9)	46.2 (174.9)	59.0 (225.7)	72.1 (272.9)	46.9 (177.5)	58.6 (221.6)	75.4 (284.0)	49.8 (188.5)	62.3 (235.8)	80.6 (305.1)	
Coil Fluid PD	FT WG (kPa)	7.1 (21.2)	6.5 (19.4)	6.5 (19.4)	4.7 (14.0)	7.6 (22.7)	7.6 (22.7)	7.7 (23.0)	6.7 (20.0)	12.6 (37.7)	6.9 (20.6)	5.1 (15.2)	9.5 (28.4)	7.8 (23.3)	5.7 (17.0)	10.7 (32.0)	
80°F DB / 64.2°F WB, 42% RH, (26.7°C DB / 17.9°C WB), 55°F DP																	
ΔT = 10°F 45°EWT 55°F LWT	Net Total	MBH (kW)	224.2 (65.7)	276.6 (81.1)	346.3 (101.5)	240.2 (70.4)	297.6 (87.2)	375.1 (109.9)	303.9 (89.1)	374.6 (109.8)	469.7 (137.7)	309.0 (90.6)	385.8 (113.1)	493.6 (144.7)	326.5 (95.7)	408.6 (119.7)	525.4 (154.0)
	Net Sensible	MBH (kW)	215.5 (63.2)	244.6 (71.7)	278.5 (81.6)	234.2 (68.6)	266.4 (78.1)	304.3 (89.2)	292.7 (85.8)	332.9 (97.6)	379.8 (111.3)	309.0 (90.6)	354.6 (103.9)	408.7 (119.8)	326.5 (95.7)	380.0 (111.4)	438.9 (128.6)
Flow Rate	GPM (l/m)	46.0 (174.1)	56.7 (214.5)	71.1 (269.1)	49.4 (187.0)	61.2 (231.7)	77.3 (292.6)	62.6 (237.0)	77.2 (292.2)	97.0 (367.2)	63.6 (240.8)	79.3 (300.2)	101.6 (384.6)	67.4 (255.1)	84.3 (319.1)	108.5 (410.7)	
Coil Fluid PD	FT WG (kPa)	7.5 (22.4)	6.2 (18.5)	11.5 (34.4)	8.6 (25.7)	7.2 (21.5)	13.4 (40.1)	7.1 (21.7)	11.0 (35.6)	17.5 (52.3)	5.5 (16.4)	9.1 (27.2)	11.7 (35.0)	6.2 (18.5)	10.2 (30.5)	13.3 (39.8)	
ΔT = 12°F 45°EWT 57°F LWT	Net Total	MBH (kW)	205.8 (60.3)	256.4 (75.1)	326.0 (95.5)	220.6 (64.7)	275.7 (80.8)	352.8 (103.4)	280.5 (82.2)	348.5 (102.1)	443.1 (129.9)	284.0 (83.2)	357.6 (104.8)	463.7 (135.9)	300.3 (88.0)	378.8 (111.0)	493.6 (144.7)
	Net Sensible	MBH (kW)	205.8 (60.3)	236.4 (69.3)	269.9 (79.1)	220.6 (64.7)	257.6 (75.5)	295.0 (86.5)	280.5 (82.2)	322.4 (94.5)	368.7 (108.1)	284.0 (83.2)	343.4 (100.6)	396.3 (116.1)	300.3 (88.0)	368.2 (107.9)	425.9 (124.8)
Flow Rate	GPM (l/m)	35.3 (133.6)	43.9 (166.2)	55.8 (211.2)	37.9 (143.5)	47.3 (179.0)	60.6 (229.4)	48.3 (182.8)	54.8 (205.7)	76.3 (288.8)	48.8 (184.7)	61.4 (232.4)	79.6 (301.3)	51.8 (196.1)	62.3 (235.8)	80.6 (305.1)	
Coil Fluid PD	FT WG (kPa)	4.5 (13.5)	7.2 (21.5)	7.3 (21.8)	5.1 (15.2)	8.3 (24.8)	8.5 (25.4)	8.4 (25.1)	7.3 (21.8)	14.0 (41.8)	7.5 (22.4)	5.6 (16.7)	10.5 (31.4)	3.7 (11.1)	6.2 (18.5)	11.9 (35.6)	
ΔT = 14°F 45°EWT 59°F LWT	Net Total	MBH (kW)	189.0 (55.4)	237.6 (69.6)	306.3 (89.8)	202.7 (59.4)	255.7 (74.9)	331.4 (97.1)	259.0 (75.9)	324.1 (95.0)	417.3 (122.3)	261.3 (76.6)	331.7 (97.2)	435.1 (127.5)	276.2 (80.9)	351.3 (103.0)	463.0 (135.7)
	Net Sensible	MBH (kW)	189.0 (55.4)	228.9 (67.1)	261.8 (76.7)	202.7 (59.4)	249.7 (73.7)	286.2 (83.9)	259.0 (75.9)	312.9 (91.7)	358.1 (104.9)	261.3 (76.6)	331.7 (97.2)	384.6 (112.7)	276.2 (80.9)	351.3 (103.0)	413.5 (121.2)
Flow Rate	GPM (l/m)	27.8 (105.2)	34.9 (132.1)	45.0 (170.3)	29.9 (113.2)	37.7 (142.7)	48.9 (185.1)	38.3 (145.0)	47.8 (180.9)	61.7 (233.6)	38.6 (146.1)	48.9 (185.1)	64.1 (242.6)	40.9 (154.8)	51.9 (196.5)	68.5 (259.3)	
Coil Fluid PD	FT WG (kPa)	4.8 (14.3)	4.8 (14.3)	7.8 (23.3)	8.4 (25.1)	5.6 (16.7)	5.4 (16.1)	9.9 (29.6)	5.4 (16.1)	8.8 (26.3)	9.4 (28.1)	4.7 (14.0)	7.8 (23.3)	6.9 (20.6)	5.3 (15.8)	4.0 (12.0)	7.9 (23.6)
75°F DB / 62.5°F WB, 50% RH, (23.9°C DB / 16.9°C WB), 55°F DP																	
ΔT = 10°F 45°EWT 55°F LWT	Net Total	MBH (kW)	183.2 (53.7)	230.5 (67.6)	295.0 (86.5)	195.9 (57.4)	247.2 (72.4)	318.7 (93.4)	249.2 (73.0)	312.4 (91.6)	400.0 (117.2)	251.2 (73.6)	319.5 (93.6)	418.1 (122.5)	264.5 (77.5)	337.6 (98.9)	444.0 (130.1)
	Net Sensible	MBH (kW)	173.5 (50.8)	198.8 (58.3)	229.3 (67.2)	188.3 (55.2)	216.1 (63.3)	250.1 (73.3)	235.6 (69.1)	270.5 (79.3)	312.4 (91.6)	248.8 (72.9)	287.2 (84.2)	335.1 (98.2)	264.5 (77.5)	307.2 (90.0)	359.2 (105.3)
Flow Rate	GPM (l/m)	37.8 (143.1)	47.5 (179.8)	60.8 (230.2)	40.6 (153.7)	51.1 (193.4)	66.0 (249.8)	51.7 (195.7)	64.7 (244.9)	83.0 (314.2)	52.1 (197.2)	66.1 (250.2)	86.5 (327.4)	55.0 (208.2)	70.1 (265.4)	92.2 (349.0)	
Coil Fluid PD	FT WG (kPa)	5.1 (15.2)	8.4 (25.1)	8.5 (25.4)	5.9 (17.6)	5.1 (15.2)	10.0 (29.9)	4.9 (14.6)	8.5 (25.4)	16.4 (49.0)	3.7 (11.1)	6.4 (19.1)	12.3 (36.8)	4.2 (12.6)	7.2 (21.5)	9.8 (29.3)	
ΔT = 12°F 45°EWT 57°F LWT	Net Total	MBH (kW)	164.4 (48.2)	209.1 (61.3)	272.9 (80.0)	175.6 (51.5)	224.2 (65.7)	294.4 (86.3)	224.8 (65.9)	284.9 (83.5)	370.9 (108.7)	225.2 (66.0)	289.9 (85.0)	385.6 (113.0)	237.6 (69.6)	306.3 (89.4)	409.4 (120.0)
	Net Sensible	MBH (kW)	164.4 (48.2)	190.2 (55.7)	220.1 (64.5)	175.6 (51.5)	206.0 (60.7)	240.0 (70.3)	224.8 (65.9)	259.4 (76.0)	300.3 (88.0)	225.2 (66.0)	275.0 (80.7)	321.7 (94.3)	237.6 (69.6)	294.8 (86.4)	345.0 (101.1)
Flow Rate	GPM (l/m)	28.4 (107.5)	36.0 (136.3)	47.0 (177.9)	30.4 (115.1)	38.9 (146.6)	50.9 (192.7)	39.0 (147.6)	49.3 (186.6)	64.3 (243.4)	39.0 (147.6)	50.1 (189.6)	66.2 (254.3)	41.3 (156.3)	51.5 (201.0)	71.0 (268.8)	
Coil Fluid PD	FT WG (kPa)	5.0 (14.9)	4.9 (14.6)	9.1 (27.2)	5.8 (17.3)	5.6 (16.7)	6.1 (18.2)	5.6 (16.7)	9.3 (27.8)	10.2 (30.5)	4.8 (14.3)	3.8 (11.4)	7.5 (22.4)	5.4 (16.1)	4.2 (12.6)	8.4 (25.1)	
ΔT = 14°F 45°EWT 59°F LWT	Net Total	MBH (kW)	147.1 (43.1)	189.4 (55.5)	251.4 (73.7)	157.3 (46.1)	203.3 (59.6)	271.2 (79.5)	202.6 (59.4)	259.5 (76.1)	342.6 (100.4)	202.0 (59.2)	262.7 (77.0)	354.9 (104.0)	213.1 (62.5)	277.7 (81.4)	376.5 (110.3)
	Net Sensible	MBH (kW)	147.1 (43.1)	182.3 (53.4)	211.2 (61.9)	157.3 (46.1)	198.6 (58.2)	230.5 (67.6)	202.6 (59.4)	249.4 (73.1)	288.7 (84.6)	202.0 (59.2)	262.7 (77.0)	309.3 (90.6)	213.1 (62.5)	277.7 (81.4)	331.8 (97.2)
Flow Rate	GPM (l/m)	21.8 (82.5)	28.0 (106.0)	37.2 (140.8)	23.4 (88.6)	30.2 (114.3)	40.3 (152.6)	30.2 (114.3)	38.6 (146.1)	51.0 (193.1)	30.1 (113.9)	39.0 (147.6)	52.7 (199.5)	31.9 (120.8)	41.4 (156.7)	56.1 (212.4)	
Coil Fluid PD	FT WG (kPa)	6.3 (18.8)	5.1 (15.2)	5.8 (17.3)	3.4 (10.2)	5.9 (17.6)	6.8 (20.3)	5.8 (17.3)	5.8 (17.3)	6.6 (19.7)	5.3 (15.8)	5.0 (14.9)	4.8 (14.3)	5.9 (17.6)	5.6 (16.7)	5.4 (16.1)	
85°F DB / 64.5°F WB, 32% RH, (29.4°C DB / 18°C WB), 52°F DP																	
ΔT = 10°F 45°EWT 55°F LWT	Net Total	MBH (kW)	255.3 (74.8)	304.9 (89.4)	368.5 (108.0)	275.4 (80.7)	329.9 (96.7)	401.0 (117.5)	346.2 (101.5)	413.6 (121.2)	501.2 (146.9)	357.9 (104.9)	431.8 (126.5)	531.6 (155.8)	379.1 (111.1)	459.8 (134.8)	568.4 (166.6)
	Net Sensible	MBH (kW)	255.3 (74.8)	299.2 (87.7)	332.9 (97.6)	275.4 (80.7)	327.2 (95.9)	365.1 (107.0)	346.2 (101.5)	408.1 (119.6)	455.4 (133.5)	357.9 (104.9)	431.8 (126.5)	497.0 (144.4)	379.1 (111.1)	459.8 (134.8)	511.1 (155.7)
Flow Rate	GPM (l/m)	52.2 (197.6)	62.3 (235.8)	75.4 (285.4)	56.4 (213.5)	67.6 (255.9)	82.4 (311.9)	100.0 (375.0)	71.0 (268.8)	84.8 (321.0)	103.1 (390.3)	73.3 (277.5)	88.4 (332.6)	109.2 (412.6)	77.8 (294.5)	94.6 (351.9)	116.9 (442.5)
Coil Fluid PD	FT WG (kPa)	4.8 (14.3)	7.5 (22.4)	12.8 (38.3)	5.6 (16.7)	8.7 (26.0)	15.1 (45.1)	9.1 (27.2)	14.2 (42.4)	19.5 (58.3)	7.2 (21.5)	7.4 (22.1)	13.4 (40.1)	8.1 (24.2)	8.4 (25.1)	15.3 (45.7)	
ΔT = 12°F 45°EWT 57°F LWT	Net Total	MBH (kW)	240.9 (70.6)	289.7 (84.9)	353.8 (103.7)	258.9 (75.9)	313.5 (91.9)	384.8 (112.8)	327.8 (96.1)	394.0 (115.5)	481.9 (141.2)	337.1 (98.8)	410.3 (120.2)	509.8 (149.4)	358.2 (105.0)	436.9 (128.0)	545.0 (159.7)
	Net Sensible	MBH (kW)	240.9 (70.6)	289.7 (84.9)	326.4 (95.7)	258.9 (75.9)	313.5 (91.9)	358.1 (104.9)	327.8 (96.1)	349.4 (101.5)	447.2						

Physical Data - MC2-CW Chilled Water (21-53kW, 6-15 Tons)

Physical Data - Chilled Water Systems (21-53kW, 6-15 Tons)

Nominal Size		21kW (6.0T)	28kW (8.0T)	35kW (10.0T)	42kW (12.0T)	53kW (15.0T)
MC2-CW Model Size		MCC-021X	MCC-028X	MCC-035X	MCC-042X	MCC-053X
Reheat / Heat - Capacity does not include fan motor heat, (Optional)						
Electric Reheat / Heat - (Optional)						
Capacity - Std Option KW	MBH (kW)	51.28 (15.03)	51.28 (15.03)	51.28 (15.03)	51.28 (15.03)	68.38 (20.04)
Stages Std / (Opt.)	NO / TXT	2 / (SCR)	2 / (SCR)	2 / (SCR)	2 / (SCR)	2 / (SCR)
Capacity - Optional KW	MBH (kW)	34.19 (10.02)	34.19 (10.02)	34.19 (10.02)	34.19 (10.02)	51.28 (15.03)
Stages Std / (Opt.)	NO / TXT	2 / (SCR)	2 / (SCR)	2 / (SCR)	2 / (SCR)	2 / (SCR)
Humidification - Electrode Steam Canister Humidifier with Adjustable Output - (Optional)						
Steam Canister	lb/hr (kg/hr)	15 (6.8)	15 (6.8)	15 (6.8)	15 (6.8)	15 (6.8)
Power Input	kW	5.1	5.1	5.1	5.1	5.1
Evaporator Fan / Motor - Direct-Drive, Backward-Inclined EC Plug Fan Impeller (Variable Speed Adjustable for Balancing)						
Airflow Rate	CFM (CMH)	3,000 (5,097)	4,000 (6,796)	5,000 (8,495)	6,000 (10,194)	7,500 (12,743)
Blower Motor / (Qty.)	kW (HP) / (NO)	4.5 (6.03) / (One)	4.5 (6.03) / (One)	4.5 (6.03) / (One)	4.5 (6.03) / (Two)	4.5 (6.03) / (Two)
E.S.P. (UP-FLOW)	IN WG	0.50	0.50	0.50	0.50	0.50
E.S.P. (DOWN-FLOW)	IN WG	0.30	0.30	0.30	0.30	0.30
Chilled Water / Dual-Cool Coil - Aluminum Fin, Copper Tube						
CW Coil Face Area	FT2 (m2)	13.32 (1.24)	13.32 (1.24)	13.32 (1.24)	19.57 (1.82)	19.57 (1.82)
DC Coil Rows / Face Area *	NO / FT2 (m2)	3 / 13.32 (1.24)	3 / 13.32 (1.24)	3 / 13.32 (1.24)	3 / 19.57 (1.82)	3 / 19.57 (1.82)
Face Velocity (Std Airflow)	FPM (m/s)	225 (1.14)	300 (1.52)	375 (1.91)	307 (1.56)	383 (1.95)
Filters - 4 in Depth, Pleated Disposable, Merv-8 Efficient						
Nom. Size (Qty.) ... MCC-UF	IN (NO)	16x24 (2) & 20x24 (2)	16x24 (2) & 20x24 (2)	16x24 (2) & 20x24 (2)	20x20 (1), 20x25 (2), 16x20 (1) & 16x25 (2)	20x20 (1), 20x25 (2), 16x20 (1) & 16x25 (2)
Nom. Size (Qty.) ... MCC-UR	IN (NO)	20x24 (2) & 24x24 (2)	20x24 (2) & 24x24 (2)	20x24 (2) & 24x24 (2)	20x24 (3), 20x20 (1) & 24x24 (2)	20x24 (3), 20x20 (1) & 24x24 (2)
Nom. Size (Qty.) ... MCC-DF	IN (NO)	16x25 (4)	16x25 (4)	16x25 (4)	16x20 (2) & 16x25 (4)	16x20 (2) & 16x25 (4)
Connection Sizes						
Cond. Drain w/ Pump	OD IN	1/2	1/2	1/2	1/2	1/2
Cond. Drain w/o Pump	PVC FPT IN	3/4	3/4	3/4	1	1
Humidifier Inlet	OD IN	1/4	1/4	1/4	1/4	1/4
Chilled Water IN/OUT	OD IN	1-3/8	1-3/8	1-3/8	1-5/8	1-5/8
Dual Cool Chilled Water IN/OUT	OD IN	1-3/8	1-3/8	1-3/8	1-5/8	1-5/8
Dimensions - (Overall Nominal, For more information see detailed dimensional drawing section)						
MCC-UF (w/o Plenum, HxWxL)	IN (mm)	76x58.5x34 (1930.4x1485.9x863.6)	76x58.5x34 (1930.4x1485.9x863.6)	76x58.5x34 (1930.4x1485.9x863.6)	76x78.5x34 (1930.4x1993.9x863.6)	76x78.5x34 (1930.4x1993.9x863.6)
MCC-UF (w/ Plenum, HxWxL)	IN (mm)	94.5x58.5x34 (2400.3x1485.9x863.6)	94.5x58.5x34 (2400.3x1485.9x863.6)	94.5x58.5x34 (2400.3x1485.9x863.6)	94.5x78.5x34 (2400.3x1993.9x863.6)	94.5x78.5x34 (2400.3x1993.9x863.6)
MCC-DF (HxWxL)	IN (mm)	84.5x58.5x34 (2146.3x1485.9x863.6)	84.5x58.5x34 (2146.3x1485.9x863.6)	84.5x58.5x34 (2146.3x1485.9x863.6)	84.5x78.5x34 (2146.3x1993.9x863.6)	84.5x78.5x34 (2146.3x1993.9x863.6)
Weight - (Approx. - Typical Unit w/ Steam Humid, Electric Reheat & Condensate Pump)						
MCC-UF	LBS (kg)	1020 (463)	1020 (463)	1020 (463)	1470 (667)	1470 (667)
MCC-DC-UF, Dual-Cool	LBS (kg)	1170 (531)	1170 (531)	1170 (531)	1670 (757)	1670 (757)
MCC-DF	LBS (kg)	1070 (485)	1070 (485)	1070 (485)	1545 (701)	1545 (701)
MCC-DC-DF, Dual-Cool	LBS (kg)	1220 (553)	1220 (553)	1220 (553)	1745 (791)	1745 (791)
Plenum Box	LBS (kg)	115 (52)	115 (52)	115 (52)	160 (73)	160 (73)
Shipping Pallet (add to above)	LBS (kg)	100 (45)	100 (45)	100 (45)	125 (57)	125 (57)

ALL SYSTEMS

Physical Data - Chilled Water Systems (63-105kW, 18-30 Tons)

Nominal Size	63kW (18.0T)	70kW (20.0T)	88kW (25.0T)	97kW (27.5T)	105kW (30.0T)
MC2-CW Model Size	MCC-063X	MCC-070X	MCC-088X	MCC-097X	MCC-105X

ALL SYSTEMS

Reheat / Heat - Capacity does not include fan motor heat, (Optional)						
Electric Reheat / Heat - (Optional)						
Capacity	MBH (kW)	68.38 (20.04)	85.47 (25.05)	85.47 (25.05)	102.57 (30.6)	102.57 (30.6)
Stages Std / (Opt.)	NO / TXT	2 / (SCR)	2 / (SCR)	2 / (SCR)	2 / (SCR)	2 / (SCR)
Capacity	MBH (kW)	51.28 (15.03)	51.28 (15.03)	68.38 (20.04)	68.38 (20.04)	68.38 (20.04)
Stages Std / (Opt.)	NO / TXT	2 / (SCR)	2 / (SCR)	2 / (SCR)	2 / (SCR)	2 / (SCR)
Humidification - Electrode Steam Canister Humidifier with Adjustable Output - (Optional)						
Steam Canister	lb/hr (kg/hr)	20 (9.1)	20 (9.1)	25 (11.3)	25 (11.3)	25 (11.3)
Power Input	kW	6.8	6.8	8.5	8.5	8.5
Evaporator Fan / Motor - Direct-Drive, Backward-Inclined EC Plug Fan Impeller (Variable Speed Adjustable for Balancing)						
Airflow Rate	CFM (CMH)	9,000 (15,291)	10,000 (16,990)	12,500 (21,238)	13,750 (23,361)	15,000 (25,485)
Blower Motor / (Qty.)	kW (HP) / (NO)	4.5 (6.03) / (Two)	4.5 (6.03) / (Two)	4.5 (6.03) / (Three)	4.5 (6.03) / (Three)	4.5 (6.03) / (Three)
E.S.P. (UP-FLOW)	IN WG	0.50	0.50	0.50	0.50	0.50
E.S.P. (DOWN-FLOW)	IN WG	0.30	0.30	0.30	0.30	0.30
Chilled Water / Dual-Cool Coil - Aluminum Fin, Copper Tube						
CW Coil Face Area	NO / FT2 (m2)	3 / 22.07 (2.05)	3 / 22.07 (2.05)	3 / 25.82 (2.40)	3 / 28.16 (2.62)	3 / 28.16 (2.62)
DC Coil Rows / Face Area *	NO / FT2 (m2)	3 / 22.07 (2.05)	3 / 22.07 (2.05)	3 / 25.82 (2.40)	3 / 28.16 (2.62)	3 / 28.16 (2.62)
Face Velocity (Std Airflow)	FPM (m/s)	408 (2.07)	453 (2.30)	484 (2.46)	488 (2.48)	533 (2.71)
Filters - 4 in Depth, Pleated Disposable, Merv-8 Efficient						
Nom. Size (Qty.) ... MCC-UF	IN (NO)	20x20 (4) & 16x20 (4)	20x20 (4) & 16x20 (4)	20x24 (3), 20x20 (1) & 16x24 (3) & 16x20 (1)	20x25 (4) & 16x25 (4)	20x25 (4) & 16x25 (4)
Nom. Size (Qty.) ... MCC-UR	IN (NO)	24x24 (3) & 20x20 (3)	24x24 (3) & 20x20 (3)	24x24 (2), 20x24 (4) & 20x20 (2)	24x24 (4) & 20x24 (4)	24x24 (4) & 20x24 (4)
Nom. Size (Qty.) ... MCC-DF	IN (NO)	16x25 (6)	16x25 (6)	16x20 (4) & 16x25 (4)	16x25 (8)	16x25 (8)
Connection Sizes						
Cond. Drain w/ Pump	OD IN	1/2	1/2	1/2	1/2	1/2
Cond. Drain w/o Pump	PVC FPT IN	1	1	1	1	1
Humidifier Inlet	OD IN	1/4	1/4	1/4	1/4	1/4
Chilled Water IN/OUT	OD IN	1-5/8	1-5/8	2-1/8	2-1/8	2-1/8
Dual Cool Chilled Water IN/OUT	OD IN	1-5/8	1-5/8	2-1/8	2-1/8	2-1/8
Dimensions - (Overall Nominal, For more information see detailed dimensional drawing section)						
MCC-UF (w/o Plenum, HxWxL)	IN (mm)	76x86.5x34 (1930.4x2197.1x863.6)	76x86.5x34 (1930.4x2197.1x863.6)	76x99.5x34 (1930.4x2527.3x863.6)	76x107x34 (1930.4x2717.8x863.6)	76x107x34 (1930.4x2717.8x863.6)
MCC-UF (w/ Plenum, HxWxL)	IN (mm)	94.5x86.5x34 (2400.3x2197.1x863.6)	94.5x86.5x34 (2400.3x2197.1x863.6)	94.5x99.5x34 (2400.3x2527.3x863.6)	94.5x107x34 (2400.3x2717.8x863.6)	94.5x107x34 (2400.3x2717.8x863.6)
MCC-DF (HxWxL)	IN (mm)	84.5x86.5x34 (2146.3x2197.1x863.6)	84.5x86.5x34 (2146.3x2197.1x863.6)	84.5x99.5x34 (2146.3x2527.3x863.6)	84.5x107x34 (2146.3x2717.8x863.6)	84.5x107x34 (2146.3x2717.8x863.6)
Weight - (Approx. - Typical Unit w/ Steam Humid, Electric Reheat & Condensate Pump)						
MCC-UF	LBS (kg)	1385 (628)	1375 (624)	1385 (628)	2085 (946)	2100 (952)
MCC-DC-UF, Dual-Cool	LBS (kg)	1635 (741)	1625 (737)	1535 (696)	2385 (1082)	2400 (1088)
MCC-DF	LBS (kg)	1485 (673)	1475 (669)	1435 (651)	2235 (1014)	2250 (1020)
MCC-DC-DF, Dual-Cool	LBS (kg)	1735 (787)	1725 (782)	1585 (719)	2535 (1150)	2550 (1156)
Plenum Box	LBS (kg)	165 (75)	165 (75)	190 (86)	205 (93)	205 (93)
Shipping Pallet (add to above)	LBS (kg)	175 (79)	175 (79)	225 (102)	275 (125)	275 (125)

ELECTRICAL COMPONENT DATA - MC2-CW

Unit Size (Nom. Tons)	MC2-CW Model	Main Power Supply	Evap Fan Motor				Electric Reheat/Heat (Optional)		Steam Humidifier (Optional)		
			Qty.	FLA	kW (HP)	Type	KW	FLA	LB/HR (kg/hr)	FLA	KW
21Kw (6.0 Tons)	MCC-021D-3-*	208/3/60	1	7.0	4.5 (6.03)	EC	15.03	41.8	15 (6.8)	14.0	5.1
	MCC-021D-3-*	460/3/60	1	5.9	4.5 (6.03)	EC	15.03	18.9	15 (6.8)	6.1	5.1
28Kw (8.0 Tons)	MCC-028D-3-*	208/3/60	1	7.0	4.5 (6.03)	EC	15.03	41.8	15 (6.8)	14.0	5.1
	MCC-028D-4-*	460/3/60	1	5.9	4.5 (6.03)	EC	15.03	18.9	15 (6.8)	6.1	5.1
35Kw (10.0 Tons)	MCC-035D-3-*	208/3/60	1	7.0	4.5 (6.03)	EC	15.03	41.8	15 (6.8)	14.0	5.1
	MCC-035D-4-*	460/3/60	1	5.9	4.5 (6.03)	EC	15.03	18.9	15 (6.8)	6.1	5.1
42Kw (12.0 Tons)	MCC-042D-3-*	208/3/60	2	7.0	4.5 (6.03)	EC	15.03	41.8	15 (6.8)	14.0	5.1
	MCC-042D-4-*	460/3/60	2	5.9	4.5 (6.03)	EC	15.03	18.9	15 (6.8)	6.1	5.1
53Kw (15.0 Tons)	MCC-053D-3-*	208/3/60	2	7.0	4.5 (6.03)	EC	20.04	55.7	15 (6.8)	14.0	5.1
	MCC-053D-4-*	460/3/60	2	5.9	4.5 (6.03)	EC	20.04	25.2	15 (6.8)	6.1	5.1
63Kw (18.0 Tons)	MCC-063D-3-*	208/3/60	2	7.0	4.5 (6.03)	EC	20.04	55.7	20 (9.1)	19.0	8.5
	MCC-063D-3-*	460/3/60	2	5.9	4.5 (6.03)	EC	20.04	25.2	20 (9.1)	8.2	8.5
70Kw (20.0 Tons)	MCC-070D-3-*	208/3/60	2	7.0	4.5 (6.03)	EC	25.05	69.6	20 (9.1)	19.0	8.5
	MCC-070D-4-*	460/3/60	2	5.9	4.5 (6.03)	EC	25.05	31.5	20 (9.1)	8.2	8.5
88Kw (25.0 Tons)	MCC-088D-3-*	208/3/60	3	6.5	4.5 (6.03)	EC	25.05	69.6	25 (11.3)	24.0	10.0
	MCC-088D-4-*	460/3/60	3	6.1	4.5 (6.03)	EC	25.05	31.5	25 (11.3)	10.0	10.0
97Kw (27.5 Tons)	MCC-097D-3-*	208/3/60	3	7.0	4.5 (6.03)	EC	30.06	83.5	25 (11.3)	24.0	10.0
	MCC-097D-4-*	460/3/60	3	5.9	4.5 (6.03)	EC	30.06	37.8	25 (11.3)	10.0	10.0
105Kw (30.0 Tons)	MCC-105D-3-*	208/3/60	3	7.0	4.5 (6.03)	EC	30.06	83.5	25 (11.3)	24.0	10.0
	MCC-105D-4-*	460/3/60	3	5.9	4.5 (6.03)	EC	30.06	37.8	25 (11.3)	10.0	10.0

MCC-021X thru MCC-053X, (21-53kW, 6-15 Tons)

MODEL	MCC-021X-		MCC-028X-		MCC-035X-		MCC-042X-		MCC-053X-	
Power Supply	208/3/60	460/3/60	208/3/60	460/3/60	208/1/60	460/3/60	208/3/60	460/3/60	208/3/60	460/3/60
Cooling Only										
FLA	7.0	5.9	7.0	5.9	7.0	5.9	14.0	11.8	14.0	11.8
MCA	8.8	7.4	8.8	7.4	8.8	7.4	17.5	14.8	17.5	14.8
MOP	15	15	15	15	15	15	30	25	30	25
with Electric Reheat and/or Heat (No Humidifier)										
FLA	48.7	24.8	48.7	24.8	48.7	24.8	55.7	30.7	69.6	37.0
MCA	60.9	31.0	60.9	31.0	60.9	31.0	69.6	38.3	87.0	46.2
MOP	70	35	70	35	70	35	70	45	90	50
with Humidifier (No Electric Reheat/Heat)										
FLA	21.0	12.0	21.0	12.0	21.0	12.0	28.0	17.9	28.0	17.9
MCA	22.8	13.5	22.8	13.5	22.8	13.5	31.5	20.9	31.5	20.9
MOP	25	15	25	15	25	15	45	30	45	30
with Electric Reheat/Heat & Humidifier										
FLA	62.7	30.9	62.7	30.9	62.7	30.9	69.7	36.8	83.6	43.1
MCA	74.9	37.1	74.9	37.1	74.9	37.1	83.6	44.4	101.0	52.3
MOP	80	40	80	40	80	40	90	50	110	60

MCC-063X thru MCC-105X, (63-105kW, 18-30 Tons)

MODEL	MCC-063X-		MCC-070X-		MCC-088X-		MCC-097X-		MCC-105X-	
Power Supply	208/3/60	460/3/60	208/3/60	460/3/60	208/3/60	460/3/60	208/3/60	460/3/60	208/3/60	460/3/60
Cooling Only										
FLA	14.0	11.8	14.0	11.8	19.5	18.2	21.0	17.7	21.0	17.7
MCA	17.5	14.8	17.5	14.8	24.4	22.7	26.3	22.1	26.3	22.1
MOP	30	25	30	25	40	40	45	35	45	35
with Electric Reheat and/or Heat (No Humidifier)										
FLA	69.6	37.0	83.5	43.2	89.0	49.6	104.4	55.4	104.4	55.4
MCA	87.0	46.2	104.4	54.1	111.3	62.0	130.5	69.3	130.5	69.3
MOP	90	50	110	60	125	70	150	70	150	70
with Humidifier (No Electric Reheat/Heat)										
FLA	33.0	20.0	33.0	20.0	43.5	28.2	45.0	27.7	45.0	27.7
MCA	36.5	23.0	36.5	23.0	48.4	32.7	50.3	32.1	50.3	32.1
MOP	50	30	50	30	60	50	70	45	70	45
with Electric Reheat/Heat & Humidifier										
FLA	88.6	45.2	102.5	51.4	113.0	59.6	128.4	65.4	128.4	65.4
MCA	106.0	54.4	123.4	62.3	135.3	72.0	154.5	79.3	154.5	79.3
MOP	110	60	125	70	150	80	175	80	175	80

Notes:

- 1) FLA = Full Load Amps; MCA = Min Circuit Amps; MOP = Max Overcurrent Protection (Max Fuse Size)
- 2) - - - - Consult local AboveAir Sales Representative for non-cataloged system power supply information.

Typical Wiring Schematic - MC2-CW (21-105kW, 6-30 Tons)

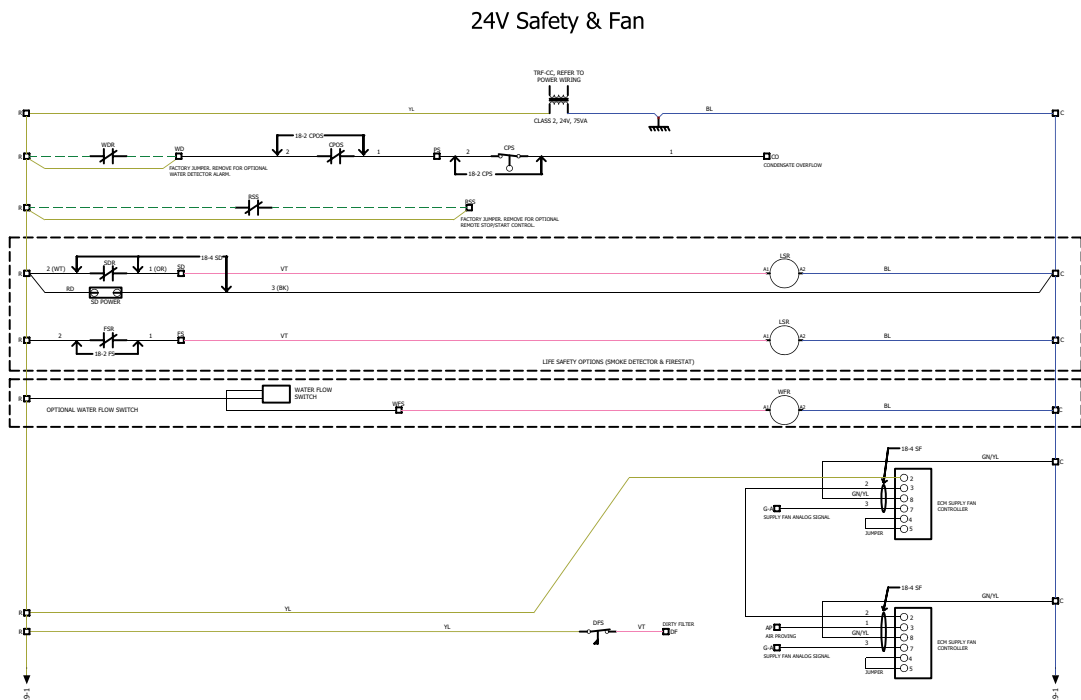
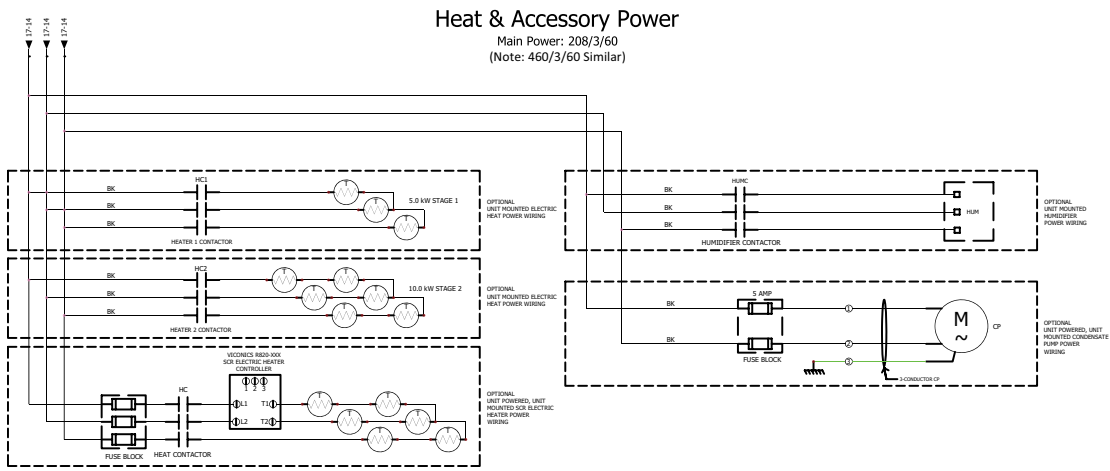
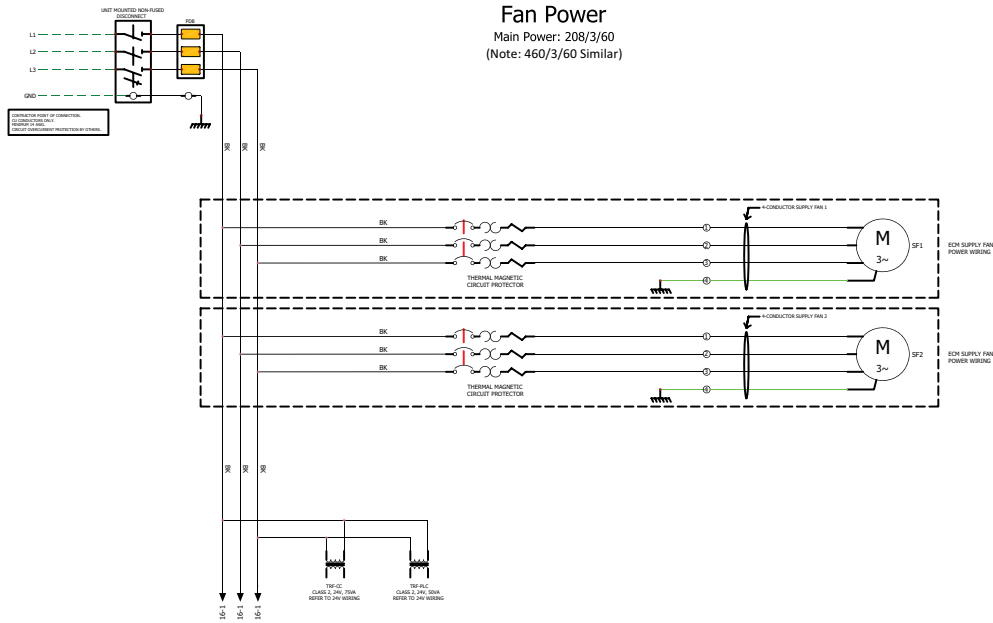

Typical Wiring Schematic - MC2-CW (21-105kW, 6-30 Tons)

24V Cooling

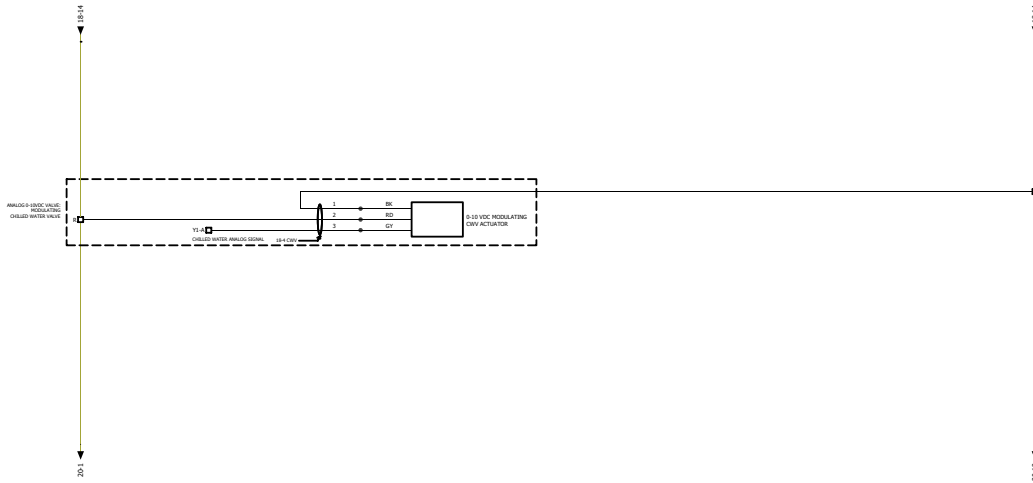

24V Heat & Humidification

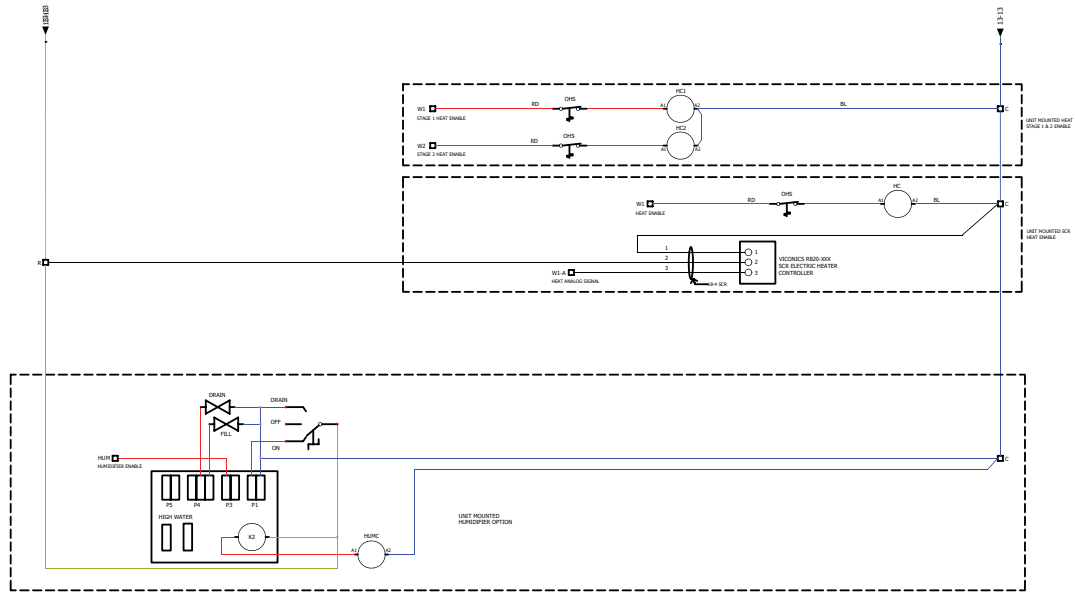

Sample Control Wiring

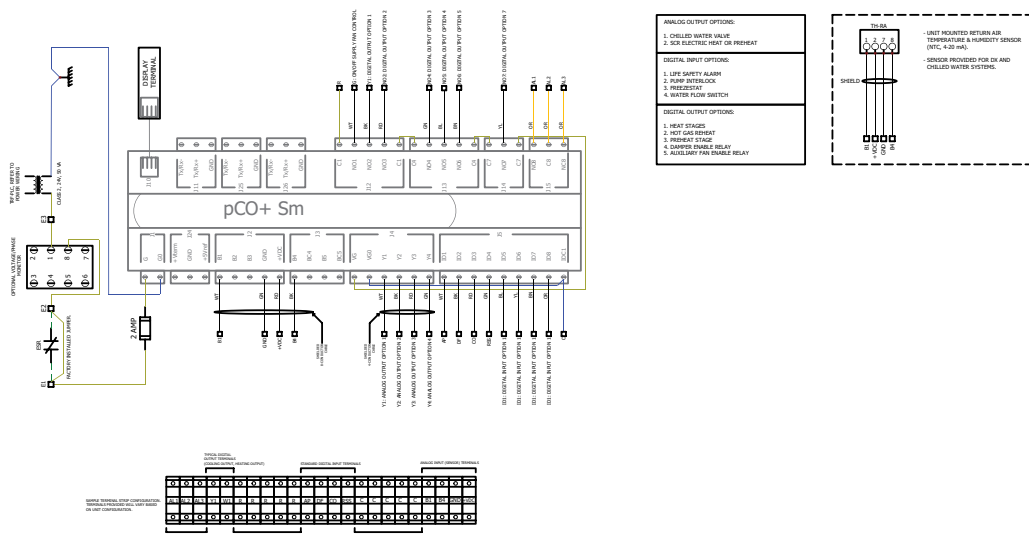

Recommended Clearance - MC2-CW (21-105kW, 6-30 Tons)

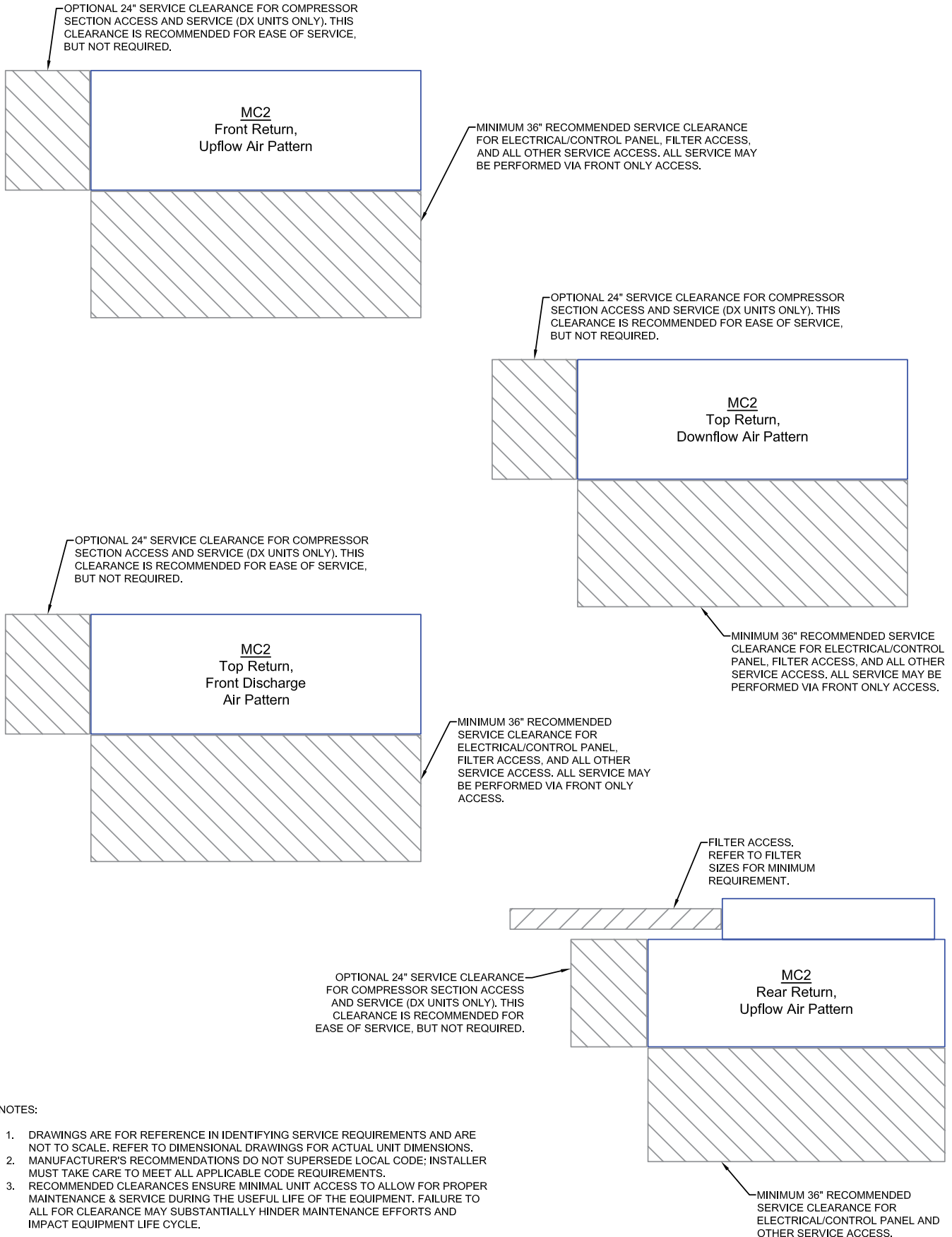

NOTES:

1. DRAWINGS ARE FOR REFERENCE IN IDENTIFYING SERVICE REQUIREMENTS AND ARE NOT TO SCALE. REFER TO DIMENSIONAL DRAWINGS FOR ACTUAL UNIT DIMENSIONS.
2. MANUFACTURER'S RECOMMENDATIONS DO NOT SUPERSEDE LOCAL CODE; INSTALLER MUST TAKE CARE TO MEET ALL APPLICABLE CODE REQUIREMENTS.
3. RECOMMENDED CLEARANCES ENSURE MINIMAL UNIT ACCESS TO ALLOW FOR PROPER MAINTENANCE & SERVICE DURING THE USEFUL LIFE OF THE EQUIPMENT. FAILURE TO ALL FOR CLEARANCE MAY SUBSTANTIALLY HINDER MAINTENANCE EFFORTS AND IMPACT EQUIPMENT LIFE CYCLE.

Chilled Water, MCC-()

Chilled Water Air Handling System (Chiller by Others)

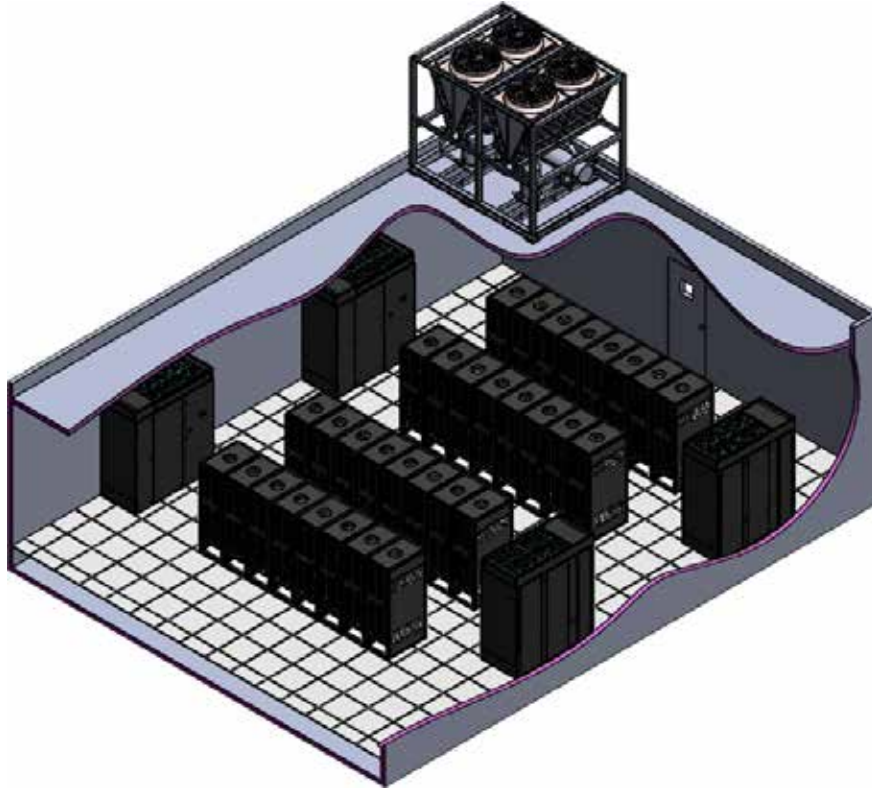

Down-Flow Air Pattern



Up-Flow Air Pattern

DOWN-FLOW: 21-35KW (6-10T), MC*-DF-A2 Cabinet

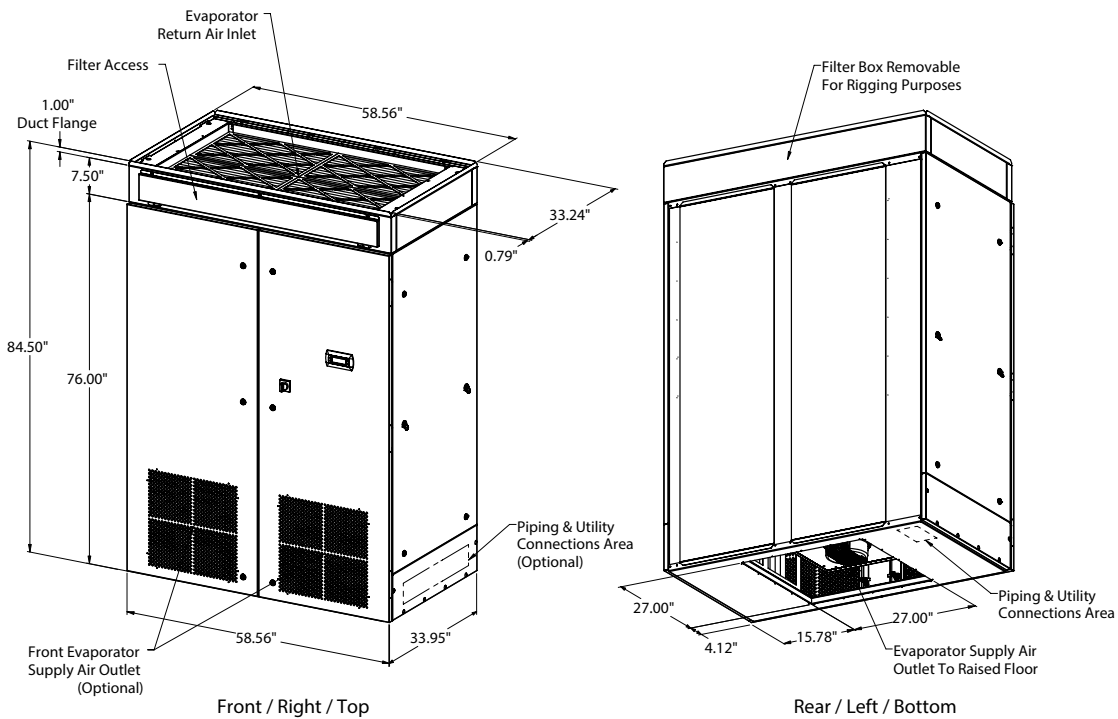

DOWN-FLOW: 42-70kW (12-20T), MC*-DF-B2 & C2 Cabinet

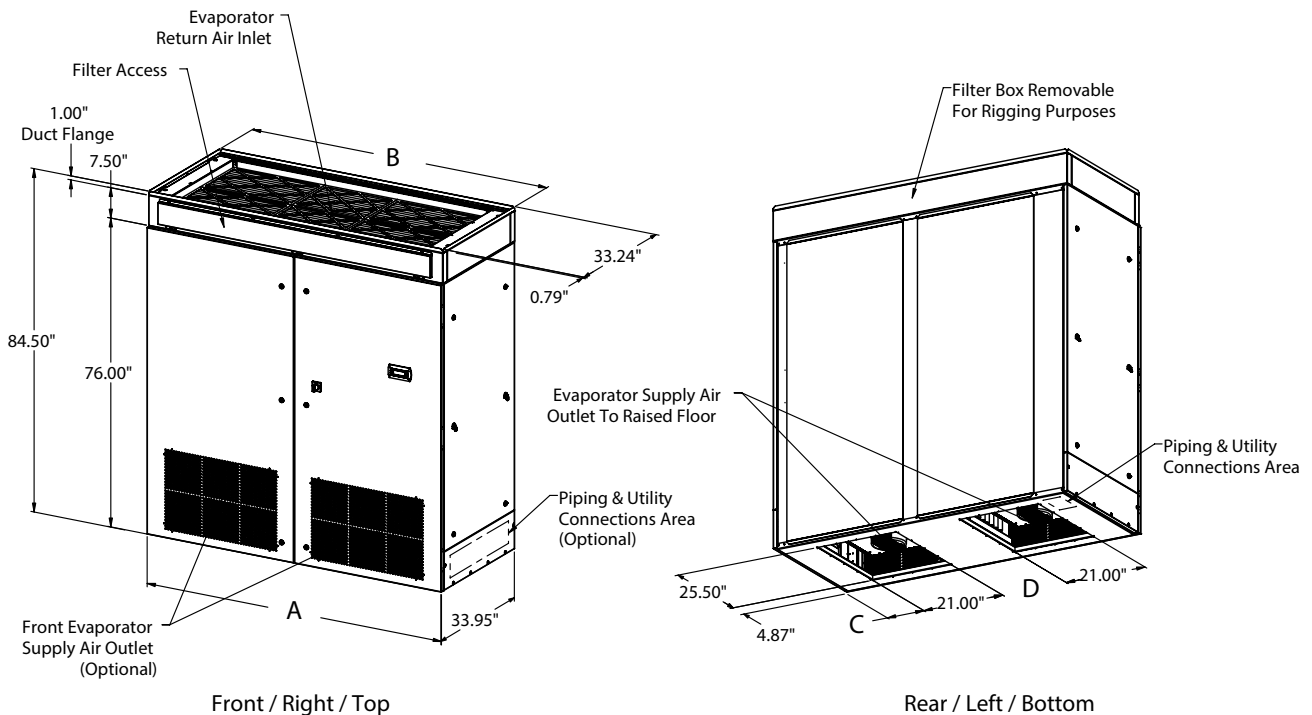

Unit Size	Model	A	B	C	D
42-53kW (12-15T)	MCC-042X/053X-*-DF-B2	78.56"	78.56"	9.78"	17.00"
63-70kW (18-20T)	MCC-063X/070X-*-DF-C2	86.56"	86.56"	11.78"	21.00"

DOWN-FLOW: 88-105kW (25-30T), MC*-DF-D2 & E2 Cabinet

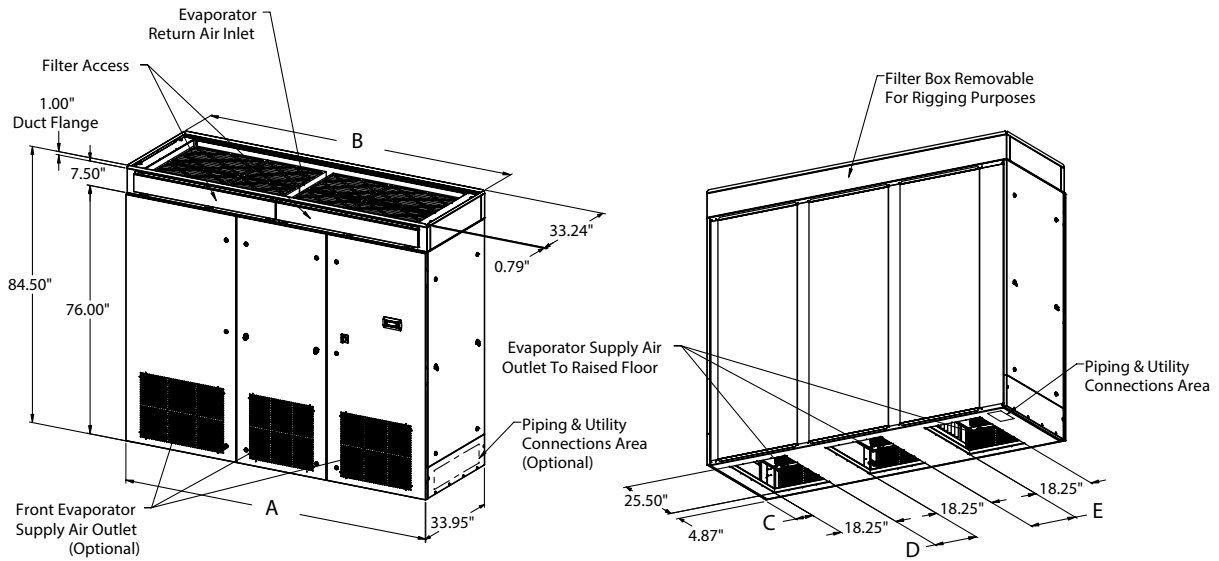

Front / Right / Top

Rear / Left / Bottom

Unit Size	Model	A	B	C	D	E
88kW (25T)	MCC-088X*-DF-D2	99.56"	99.56"	5.66"	13.50"	14.75"
97-105kW (27.5-30T)	MCC-097X/105X*-DF-E2	107.06"	107.06"	6.41"	15.50"	18.00"

UP-FLOW: 21-35KW (6-10T), MC*-UF-A2 Cabinet

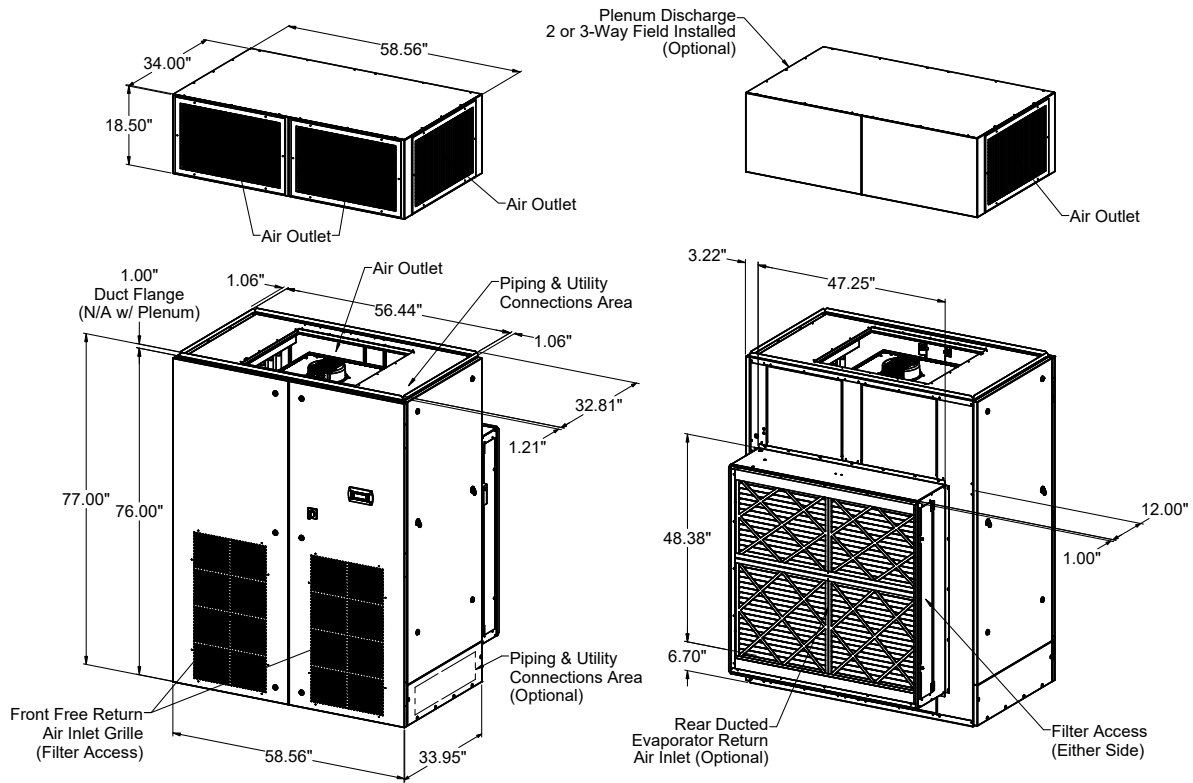

Front / Right / Top

Rear / Left / Top

Dimensional Data

UP-FLOW: 42-70kW (12-20T), MC*-UF-B2 & C2 Cabinet

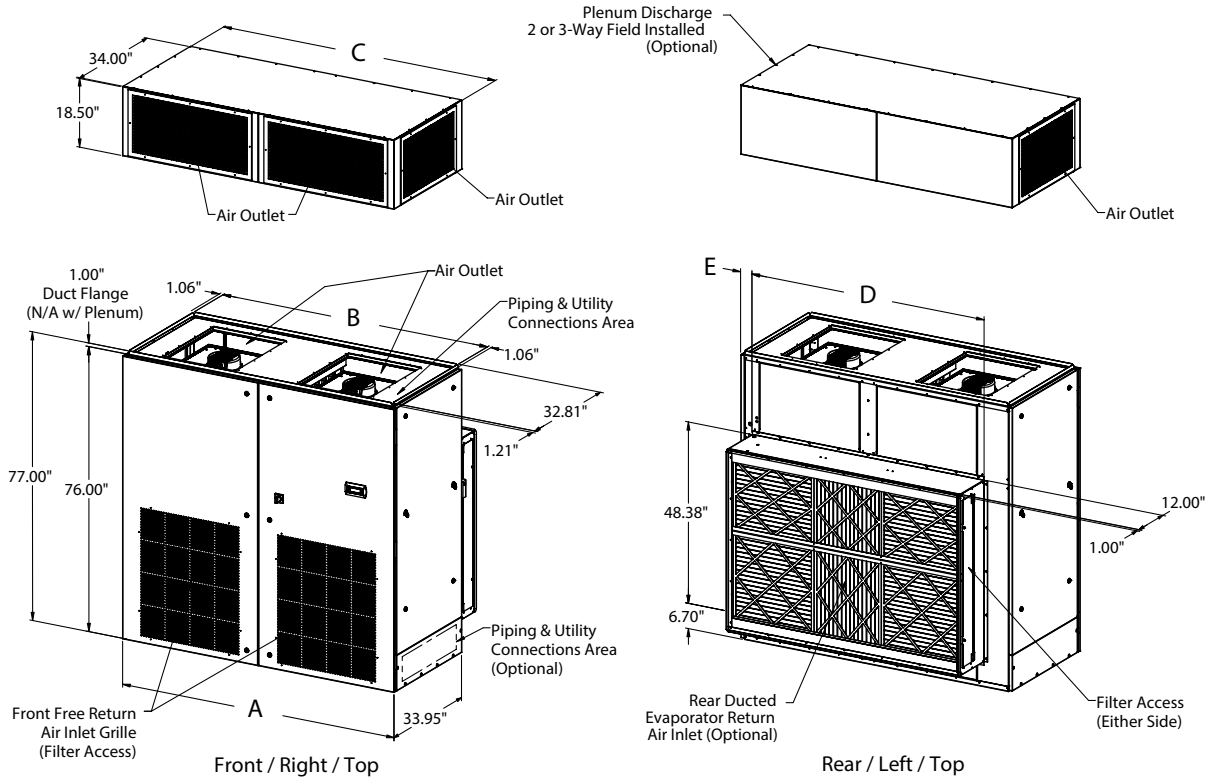

Unit Size	Model	A	B	C	D	E
42-53kW (12-15T)	MCC-042X/053X*-UF-B2	78.56"	76.44"	78.56"	67.13"	3.28"
63-70kW (18-20T)	MCC-063X/070X*-UF-C2	86.56"	84.44"	86.56"	71.13"	5.28"

UP-FLOW: 88-105kW (25-30T), MC*-UF-D2 & E2 Cabinet

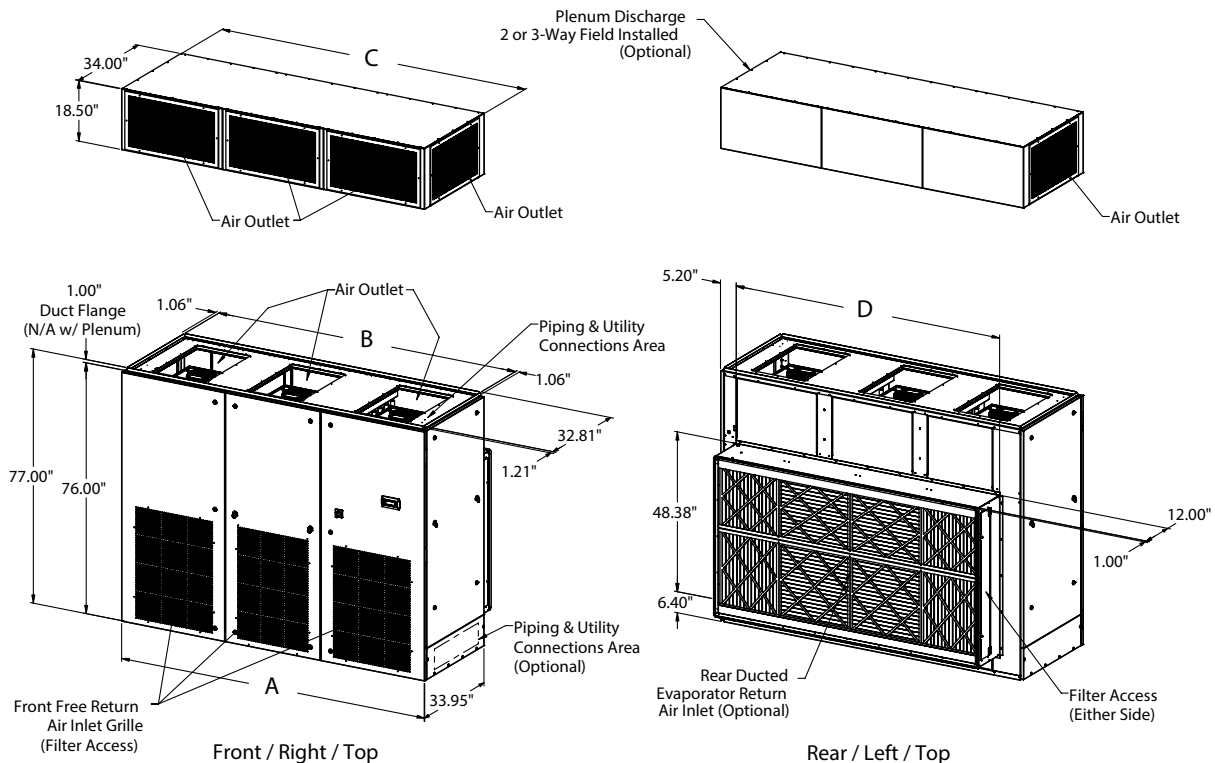

Unit Size	Model	A	B	C	D
88kW (25T)	MCC-088X*-UF-D2	99.56"	97.44"	99.56"	86.50"
97-105kW (27.5-30T)	MCC-097X/105X*-UF-E2	107.06"	104.94"	107.06"	94.50"

Floor Stand Options

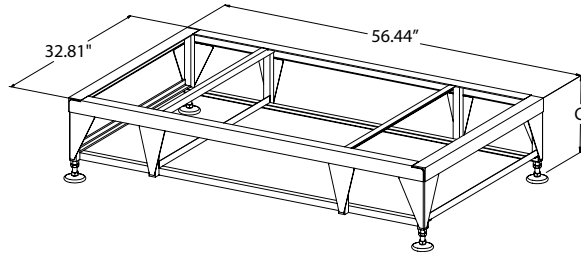

A-Cabinet ... 21-35kW (6-10 Tons)

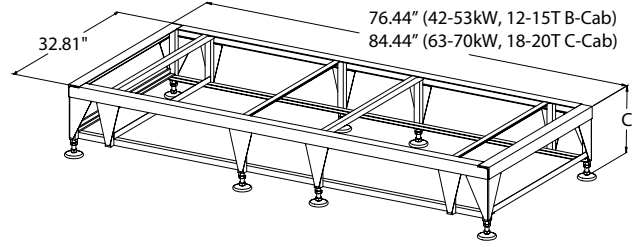

B & C-Cabinets ... 42-70kW (12-20 Tons)

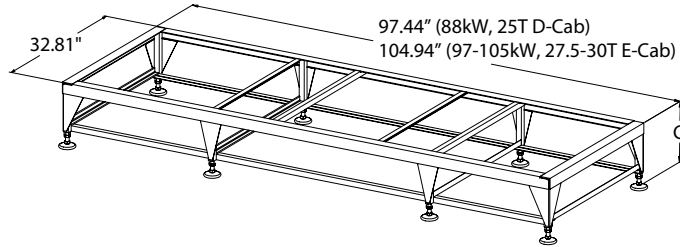

D & E-Cabinets ... 88-105kW (25-30 Tons)

Floor Stand Model (MC2-CW)	Nominal Height "C"	Nominal Weight (lbs) - (Shipping Skid Not Included)									
		A-Cabinet (21-35kW, 6-10T)		B-Cabinet (42-53kW, 12-15T)		C-Cabinet (63-70kW, 18-20T)		D-Cabinet (88kW, 25T)		E-Cabinet (97-105kW, 27.5-30T)	
		Floor Stand	Turning Vane	Floor Stand	Turning Vanes	Floor Stand	Turning Vanes	Floor Stand	Turning Vanes	Floor Stand	Turning Vanes
FS2P-04	4.0" (3.75"-4.75" Adj.)	44	N/A	61	N/A	64	N/A	69	N/A	72	N/A
FS2P-05	5.0" (4.25"-5.38" Adj.)	44	N/A	61	N/A	64	N/A	69	N/A	72	N/A
FS2P-06	6.0" (5.25"-8.25" Adj.)	44	N/A	61	N/A	65	N/A	70	N/A	73	N/A
FS2P-09	9.0" (8.25"-11.25" Adj.)	47	N/A	67	N/A	70	N/A	75	N/A	78	N/A
FS2P-12	12.0" (11.25"-14.25" Adj.)	70	16	99	29	103	30	101	38	105	38
FS2P-15	15.0" (14.25"-17.25" Adj.)	75	18	105	32	110	32	105	41	109	41
FS2P-18	18.0" (17.25"-20.25" Adj.)	80	21	112	37	116	38	110	47	114	47
FS2P-24	24.0" (23.25"-26.25" Adj.)	89	24	125	43	129	44	119	56	123	56

Innovative HVAC Solutions

MissionCritical Units - Precision A/C's



**SC-2x4 SpotCool
Ceiling Mounted A/C's**
(4-11kW, 1-3 Tons)



**HK Horizontal Ducted
Ceiling Mounted A/C's**
(4-70kW, 1-20 Tons)



**MC Vertical Floor Mtd A/C's
Up-Flow & Down-Flow**
(4-1080kW, 1-307 Tons)



**WC Wall-Cassette and
FC Floor-Console Mtd A/C's**
(4-18kW, 1-5 Tons)

Outdoor-Air Units - IAQ High Percent (20%-100% OA)



HK-OA Horizontal Ceiling Mtd
(1-30 Tons)



VK-OA Vertical Floor Mtd
(1-50 Tons)

Specialty Units - A/C's & Water Source Heat Pumps



**SC-2x4 SpotCool
Ceiling Mtd A/C's**
(4-11kW, 1-3 Tons)



**HK Horizontal Packaged
& Split Ceiling Mtd A/C's**
(4-70kW, 1-20 Tons)



**VK Vertical Packaged &
Split Floor Mtd A/C's**
(4-105kW, 1-30 Tons)

Remote Heat Rejection Units



**Remote Air Cooled
Condensers, Condensing Units &
Glycol Drycoolers**

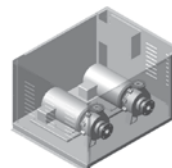

**Single, Dual & Triplex
Glycol Pump Packages**
(1/2 to 50 HP, VFD Optional)