

Engineering Manual

MC-2x2™

Mission Critical

Vertical Floor Mounted A/C's
(Single Circuit DX & CW)



Features & Benefits

- > 4 to 11 kW (1-3 Tons) Capacities
- > Precision Applications
 - Small Computer Rooms
 - Network / Server Closets
 - IDF / MDF / AV Rooms
 - Equipment Control Rooms
- > Compact Vertical Floor Mounted Upflow & Downflow Configurations
- > DX Air, Water & Glycol Cooled Plus Chilled Water Systems
- > Total Temp & Humidity Control
 - Reheat/Heat via Electric, Free-Energy Hot Gas, Hot Water or Steam
 - Steam Humidifier
- > Microprocessor Controls & More

From
4 to 11 kW

Compact
24"W x 24"D
Footprint

AboveAir™ MissionCritical™ vertical floor mounted precision air conditioners are the reliable environmental control solution to your precision cooling needs. Available in a wide variety of cooling methods and cabinet configurations including a full range of options, **AboveAir™** Air Conditioners are a step above!

- ☑ 100% Front-Access cabinet design
- ☑ Total Temperature & Humidity Control
- ☑ Up-Flow & Down-Flow air patterns
- ☑ Variety of cooling methods
- ☑ Self-contained & split systems
- ☑ Flexible options and accessories
- ☑ R410a Refrigerant
- ☑ Energy efficient operation

Contents

| | |
|----------------------------------|-------------|
| Introduction | 2 |
| Model Configurations | 2 |
| Features and Benefits | 3 |
| Model Nomenclature | 4 |
| Guide Specifications | 5-10 |
| DX - Cooling Capacity Data | 11-14 |
| CW - Cooling Capacity Data | 15 |
| DX & CW Unit Physical Data | 16 |
| Electrical Data | 17-20 |
| Dimensional Data | 21-23 |
| Other AboveAir Products | Back Cover! |

DX - Air Cooled

MCH & XPU-()

DX - Air Cooled Split with Propeller Fan, Outdoor Remote Condensing Unit

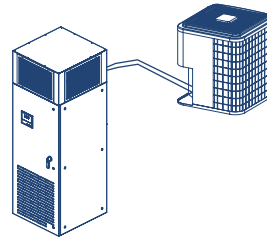

MCE & XP1-()

DX - Air Cooled Split with Propeller Fan, Outdoor Remote Condenser

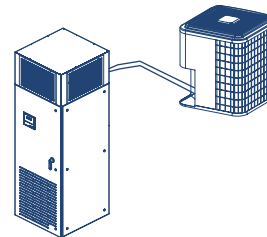

MCH/E & CCU/CCX & XCU/XCX -()

DX - Air Cooled Split with Centrifugal Blower, indoor Remote Condensing Unit & Condensers

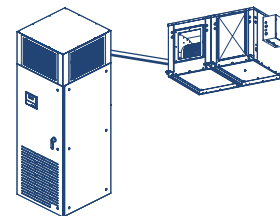

DX - Water/Glycol Cooled

MCW & MCG-()

DX - Water/Glycol Cooled Self-Contained Plus Glycol Drycoolers & Pump Packages

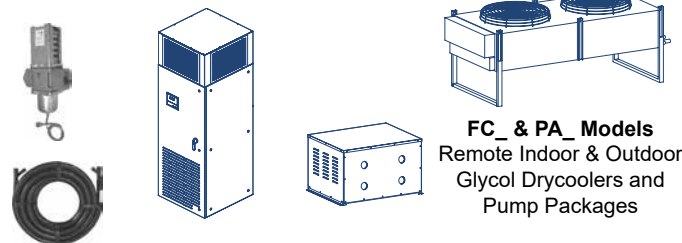

FC_ & PA_ Models
Remote Indoor & Outdoor
Glycol Drycoolers and
Pump Packages

Chilled Water Systems

MCC-()

Chilled Water Air Handling Units



FEATURES & BENEFITS

AboveAir™ MissionCritical™ precision A/C's are designed to meet your unique application dependent requirements. Select from a wide range of options and configurations:



Up-Flow Air Pattern

4-11kW (1-3T)

Single Circuit DX &
Chilled Water

**Compact 24"W x 24"D
Footprint!**



Down-Flow Air Pattern

Variety of Standard & Optional Features



Standard & Optional Features:

- MC-2000, Advanced Microprocessor Controls
- Electrode Steam Canister Humidifier
- Dehumidification Mode with Electric, Hot Gas, Hot Water or Steam Reheat
- Scroll Compressor (Fixed, 2-Spd or Digital)
- EC Backward-Inclined Plug Fan
- High Efficiency Air Filtration
- Low Ambient Head Pressure Control
- 2 & 3-Way 150 psig to 400 psig Water/Glycol Cooled Regulating Valves
- Hot Gas Bypass
- Low Entering Condenser Water/Glycol Kit
- Top or Bottom Piping Connections

Accessories:

- 2 or 3-Way Plenum Discharge Boxes
- Floor Stands & Turning Vanes
- Condensate Pumps - Factory Installed
- Main Power Electrical Disconnects
- Firestats
- Smoke Detectors
- Remote Water-Leak Detectors
- Compressor Sound Jackets
- Glycol Pump Packages & Drycoolers
- ... and more!



Model Nomenclature

Packaged Systems & Split Evaporators

Split, DX - Remote Condensers & Condensing Units

| | | | | | | | |
|-----------|----------------|-------------------|-----------|--------------------|--------------|-------------|-------------|
| MC | E - 011 | S - 4 - 00 | ER | H - EC - 00 | - UF2 | - 2X | - S3 |
| a | b - c | d - e - f | g | h - i - j | - k | - l | - m |

- a: MC** - MissionCritical MC2x2 Vertical Floor A/C
- b: C** - Chilled Water Air Handling Unit
E - DX, Split Evaporator (Compressor with Evaporator)
G - DX, Glycol Cooled - Packaged Self-Contained
H - DX, Split Air Handling Unit
W - DX, Water Cooled - Packaged Self-Contained
- c: 004** = 4.0kW (1.0T); **005** = 5kW (1.5T); **007** = 7kW (2.0T); **009** = 9kW (2.5T); **011** = 11kW (3.0T)
- d: S** - Single Circuit DX System
X - Chilled Water System
- e: 1** - 208-230V / 1 Ph / 60 Hz
3 - 208-230V / 3 Ph / 60 Hz
4 - 460-480V / 3 Ph / 60 Hz
5 - 575V / 3 Ph / 60 Hz
7 - 277V / 1 Ph / 60 Hz
8 - 460-480V / 1 Ph / 60 Hz
- f: 00** - No Hot Gas Reheat
HG - Hot Gas Reheat (2-POS, On/Off)
MG - Hot Gas Reheat (Modulating 0-10Vdc)
HR - Hot Water Reheat/Heating Coil
SR - Steam Reheat/Heating Coil
- g: 00** - No Unit Mtd Electric Heat
EO - Electric Heat Only, No Reheat
ER - Electric Reheat/Heat
- h: 0** - No Humidifier
H - Electrode Canister Steam Humidifier
- i: EC** - EC = EC Plug Fan (Direct-Drive, Backward-Inclined Centrifugal Impeller, 0-10Vdc)
- j: 00** - No Economizer
DC - Dual Cool / Alternate Water Source Coil
FE - Water/Glycol Side Free Cooling Economizer Coil
(DC/FE Option Requires Upsized Dimensional Cabinet!)
- k: DFB** - Down-Flow Evap Air Pattern w/ Free or Ducted Top Return & Bottom Discharge to Raised Floor
DFF - Down-Flow Evap Air Pattern w/ Free or Ducted Top Return & Front Free-Discharge to Floor Level
UF0 - Up-Flow Evap Air Pattern w/ Front Free-Return & Top Ducted Discharge
UF1 - Up-Flow Evap Air Pattern w/ Front Free-Return & Top 1-Way Plenum Discharge Box
UF2 - Up-Flow Evap Air Pattern w/ Front Free-Return & Top 2-Way Plenum Discharge Box
UF3 - Up-Flow Evap Air Pattern w/ Front Free-Return & Top 3-Way Plenum Discharge Box
UFR - Up-Flow Evap Air Pattern w/ Rear Ducted or Free-Return & Top Ducted Discharge
- l: 2X** - 2X = MC2x2 24"x24" Footprint Cabinet ... 4-11kW (1-3T)
- m: 00** - No Compressor (*Compressor located in remote condensing section*)
S1 - Fixed Speed Scroll Compressor w/ Hot Gas Bypass
S3 - 2-Speed Scroll Compressor Option
S6 - Modulating Digital Scroll Compressor Option
CX - Chilled Water Valve - 2-Way, 300 psi (MOD, 0-10 VDC)
DX - Chilled Water Valve - 3-Way, 300 psi (MOD, 0-10 VDC)
EX - Chilled Water Valve by Others

| | | | | |
|------------|--------------|----------------------|--------------|----------------|
| XP1 | - 011 | S - 4 - AA | - VF | 1 - 0 B |
| a | - b | c - d - e - f | g - h | i |

- a: CCU** - DX, Split Indoor Ceiling Mtd Remote Air Cooled Centrifugal Blower Condensing Unit (Compr w/ CCU Cond Unit)
CCX - DX, Split Indoor Ceiling Mtd Remote Air Cooled Centrifugal Blower Condenser (Compr Located w/ MCE Evap)
CGU - DX, Split Indoor Ceiling or Floor Mtd Remote Glycol Cooled Condensing Unit (Compr w/ CGU Cond Unit)
CWU - DX, Split Indoor Ceiling or Floor Mtd Remote Water Cooled Condensing Unit (Compr w/ CWU Cond Unit)
XP1 - DX, Split Outdoor Mtd Remote Air Cooled Propeller Fan Condenser (Compr Located w/ MCE Evap)
XPU - DX, Split Outdoor Mtd Remote Air Cooled Propeller Fan Condensing Unit (Compr w/ XPU Cond Unit)
- b: 004** = 4.0kW (1.0T); **005** = 5kW (1.5T); **007** = 7kW (2.0T); **009** = 9kW (2.5T); **011** = 11kW (3.0T)
- c: S** - Single Circuit DX System
- d: 1** - 208-230V / 1 Ph / 60 Hz
3 - 208-230V / 3 Ph / 60 Hz
4 - 460-480V / 3 Ph / 60 Hz
5 - 575V / 3 Ph / 60 Hz
7 - 277V / 1 Ph / 60 Hz
8 - 460-480V / 1 Ph / 60 Hz
- e: 00** - N/A
AA - Axial Fan w/ Std Motor
AB - DWDI FC BD Blower w/ ODP Motor
AD - Direct-Drive DWDI FC Blower w/ PSC Motor
EA - Axial Fan w/ ECM
EC - EC DD Backward-Inclined Impeller
ED - Direct-Drive DWDI FC Blower w/ ECM Motor
- f: 00** - Not Applicable
LD - Ducted, 90 Degree / Right-Angle, In-Front / Out Left-Side
MI - Ducted, Mirror-Image Same-Face Condenser Air Pattern
RD - Ducted, 90 Degree / Right-Angle, In-Rear / Out Right-Side
SF - Ducted, Same Face Condenser Air Pattern
ST - Ducted, Straight-Thru Condenser Air Pattern
VF - Free Airflow, Vertical Discharge Air Pattern
- g: 0** - Not Applicable
1 - Slab or Wrap Around Type Condenser/Condensing Unit
S - SpotCool Condenser Section
- h: 0** - No Compressor (*Compressor located in evaporator section*)
1 - Fixed Speed Scroll Compressor w/ Hot Gas Bypass
2 - Fixed Speed Scroll Compressor w/ Quench Hot Gas Bypass
3 - 2-Speed Scroll Compressor Option
6 - Modulating Digital Scroll Compressor Option (4kW, 3T Only)
- i: 0** - Not Applicable / No Head Pressure Control
1 - Low Amb ECM Variable Speed Fan Head Pressure Control
A - Low Amb Fan Cycling Head Pressure Control
B - Low Amb Variable Speed Fan Head Pressure Control
C - Low Amb Flooded Head Pressure Control
D - Water/Glycol Regulating Valve - 2-Way, 150 psig
E - Water/Glycol Regulating Valve - 2-Way, 350 psig
F - Water/Glycol Regulating Valve - 3-Way, 150 psig
G - Water/Glycol Regulating Valve - 3-Way, 350 psig

General

Summary



These specifications describe the requirements for a vertical floor mounted packaged (or split) precision air conditioner. The system shall be designed to control space temperature and humidity.

The air conditioning manufacturer shall design and furnish all equipment in the quantities and configurations shown on the project plans and specifications.

The system shall be provided by Above-Air Technologies in Frederick, Maryland, USA. The system shall be listed by Intertek (ETL Semko), Inc. to conform with UL Std 1995 and be certified to CAN/CSA Std C22.2 No. 236 (Control No. 3091370). The system shall be NYC MEA229-06-E and Chicago Code Approved. The system model number shall be _____.

Design Requirements

The system shall be an AboveAir Technologies MissionCritical™ brand factory assembled and tested. The system shall be designed for indoor installation.

The system shall have a total cooling capacity of _____ BTU/H, and a sensible cooling capacity of _____ BTU/H, based on an entering air condition of _____ °F DB, and _____ °F WB, _____ % RH.

The evaporator section shall be designed for _____ Volt, _____ Phase, _____ Hertz main power supply. The remote condensing unit section (if applicable) shall be designed for _____ Volt, _____ Phase, _____ Hertz main power supply.

Submittals

Submittals shall be provided after manufacturer's receipt of a written purchase order and shall include: Detailed Performance and Electrical Data; Guide Specifications; and Dimensional Drawings.

Quality Assurance

The system shall be factory run tested prior to shipment. Testing shall include, but shall not be limited to: "HiPot" Test (2 times rated voltage plus 1000 volts, per UL 1995 testing requirements). The system shall be designed and manufactured according to world class quality standards.

Products

Standard Features

Cabinet

The cabinet chassis and access panels shall be powder-coat painted heavy gauge galvanized steel for decor matching and corrosion resistance. Cabinet access panels shall rest in recessed pockets designed for minimum air leakage. The cabinet and access panels shall be lined with 2 lb/ft² high density sound and thermal insulation and sealed with self-extinguishing gasketing conforming to NFPA 90A and 90B.

Component Access

The unit shall be serviceable through front access panels with quick-release quarter-turn fasteners.

Electrical System

General:

The electrical system shall conform to National Electric Code (NEC) requirements according to UL 1995. The control circuit shall be a 24 VAC low voltage circuit.

The electrical system shall include, but not be limited to the following factory installed items: main power distribution block; grounding lug; 24 VAC control transformer; terminal connections; and motor controllers with start protection and circuit breakers for blower motors, compressors and each electric heater stage (if applicable).

Packaged Systems: (single point power)

Self-Contained systems shall be designed for single point main power connection.

Split DX Systems: (separate power)

Split systems shall require separate main power supplies to the evaporator and condensing unit sections. The evaporator and condensing unit sections shall be electrically interlocked by a field wired 24 volt control signal.

Overflow Safety Float Switch:

The system shall be provided with a factory installed float type condensate overflow safety switch. The circuit shall be designed to shut down all system water producing operations in the event of an overflow condition.

Main Power, Disconnect

(MC_ Evap Section)



The indoor evaporator section shall be provided with a factory installed main power non-fused disconnect. The disconnect shall be NEMA rated for indoor or outdoor installation as required.

Air Distribution

EC Backward-Inclined Plug Fan



The evaporator blower assembly shall be a backward-inclined direct-drive centrifugal impeller with variable speed EC (electronically communicated) motor. The blower shall be designed for _____ CFM @ _____ inches external static pressure (e.s.p.)

Variety of Air Patterns



Up-Flow (UF) Down-Flow (DF)

Up-Flow Air Pattern:

UFFR: Front-Free Return

The system shall be configured for up-flow evaporator air pattern with front-free return and top discharge. (Refer to *Plenum Discharge Box Options*.)

UFFR: Rear-Ducted Return

The system shall be configured for up-flow evaporator air pattern with rear ducted return and top discharge.

Down-Flow Air Pattern:

DFB: Bottom Disch Into Raised Floor

The system shall be configured for down-flow evaporator air pattern with top free or ducted return and bottom discharge into raised floor. (Refer to Floor Stand Options.)

DFE: Front Discharge Floor Level

The system shall be configured for down-flow evaporator air pattern with top free or ducted return and front free discharge to floor level.

Air Filtration



The filter shall be a 2 inch thick pleated and Merv- efficiency rated (based on ASHRAE 52.2). The filter shall be serviceable through a side access panel without shutting down the system.

Piping Connection Location

- Top Piping Connections
- Lower-Side Piping Connections
- Bottom Piping Connections

Direct Expansion Systems

DX - Evaporator Coil



The DX evaporator coil shall be constructed of copper tubes and aluminum fins. The system shall be designed for a draw-through air pattern for maximum heat transfer. Coil end-plates shall be hot dipped galvanized. The evaporator coil shall be mounted in an insulated stainless steel condensate drain pan.

Scroll Compressors



Each compressor shall be the high efficiency, low sound Scroll type mounted

on vibration isolators and located in a separate compartment out of the evaporator air stream to facilitate servicing while equipment is operating. Each compressor shall be complete with reversible positive oil pump, charging and service ports, internal spring isolation, and discharge gas vibration eliminator.

(Note: 2-Speed Scroll Compressors are optionally available above 5-11kW (1.5-3 Tons) and Modulating Digital Scroll is available for 11kW (3 Ton) Models !

DX - Refrigeration Circuit



Each refrigeration circuit shall be pre-piped with type "L" refrigerant copper tubing. The refrigeration system shall include but not be limited to: expansion valve with external equalizer and rapid bleed-through capacity. Features shall include filter dryer, sight glass, pressure fittings and high pressure/low pressure safety cutouts.

Cooling Configurations

DX - Air Cooled Systems

DX - Air Cooled Split

(Split Evap & Outdoor Remote Condenser) MCE-() & XP1-()

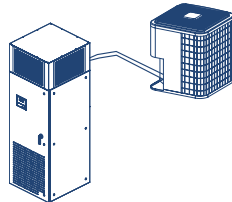

The system shall be a split configuration with compact 24" x 24" maximum foot-print indoor vertical floor mounted dx evaporator precision air conditioner with outdoor dx air cooled propeller fan remote condenser. The compressor shall be located in the indoor evaporator section. The condenser shall be sized for full heat of rejection at 95°F ambient and be capable of operation to ___ °F low ambient air temperature.

The system shall be refrigerant charged and run tested at the factory prior to shipment. The evaporator and condenser sections shall ship separately with a dry-nitrogen charge ready for field refrigerant charging.

DX - Air Cooled Split

(Air Handling & Outdoor Remote Condensing Units) MCH-() & XPU-()

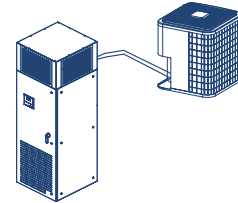

The system shall be a split configuration with compact 24" x 24" maximum foot-print indoor vertical floor mounted precision dx air handling unit with outdoor dx air cooled propeller fan remote condensing unit. The compressor shall be located in the condensing unit. The condensing unit shall be sized for full heat of rejection at 95°F ambient and be capable of operation to ___ °F low ambient air temperature.

The system shall be refrigerant charged and run tested at the factory prior to shipment. The evaporator and condensing unit sections shall ship separately with a dry-nitrogen charge ready for field refrigerant charging.

DX - Air Cooled Split (Air Handler & Indoor Remote Condensing Unit)

MCH-() & CCU or XCU-()

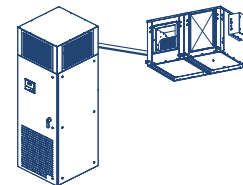

The system shall be a split configuration with compact 24" x 24" maximum foot-print indoor vertical floor mounted precision dx air handling unit with indoor dx - air cooled centrifugal blower remote condensing unit. The compressor shall be located in the condensing unit. The condensing unit shall be sized for full heat of rejection at 95°F ambient and be capable of operation to ___ °F low ambient air temperature.

The system shall factory tested prior to shipment. The air handling and condensing unit sections shall ship separately from the factory with a dry-nitrogen holding charge for field sweat (copper) connection and refrigerant charging.

DX - Water Cooled

(Self-Contained Systems) MCW-()



The system shall be a self-contained, compact 24" x 24" maximum foot-print indoor vertical floor mounted dx water cooled precision air conditioner. The system shall include a water cooled tube-in-tube coaxial condenser and factory installed head pressure controlling 2-way water regulating valve rated for 150 psi w.w.p. The water cooled condenser shall be designed to provide the total required system heat of rejection at 85°F entering water temperature and 95°F leaving water temperature. Source water shall be provided by a remote water source (by others).

The system shall require only single point main power supply and ship from the factory with a full operating refrigerant charge.

(Note: 3-Way and High Pressure valves are optionally available)

DX - Glycol Cooled

(Self-Contained Systems) MCG-()



The system shall be a self-contained, compact 24" x 24" maximum foot-print indoor vertical floor mounted dx glycol cooled precision air conditioner. The system shall include a glycol cooled tube-in-tube coaxial condenser and factory installed head pressure controlling 2-way glycol regulating valve rated for 150 psi w.w.p. The condenser shall be designed to provide the total required system heat of rejection at 110°F entering glycol temperature and 120°F leaving glycol temperature based on 40% ethylene glycol solution. Source glycol shall be provided by a remote glycol drycooler source (see AboveAir Technologies' FluidCool™ drycoolers).

The system shall require only single point main power supply and shall ship from the factory with a full operating refrigerant charge.

(Note: 3-Way and High Pressure valves are optionally available)

Glycol Pump Packages & Drycoolers

FC_-() / PA_-()



Glycol condenser source shall be provided by a FluidCool™ brand remote air cooled glycol drycooler and Pump-All™ brand pump package.

The glycol drycooler shall be the outdoor mounted propeller fan type complete with factory installed aquastat fan cycling controls, motor starters with overload protection and non-fused disconnect switch.

The glycol pump package shall be a (single or dual) pump package designed for outdoor installation complete with individual pump motor starters. Dual glycol pump packages shall be provided with manual lead-lag switch and field installed flow switch for automatic switchover to backup pump upon loss of flow.

An expansion tank and air purge fitting valve shall be factory provided for field installation.

The drycooler shall provide _____ BTUH total heat rejection at a flow rate of _____ GPM with _____ °F EGT and _____ °F LGT at _____ °F ambient air temperature. Each pump shall be _____ Hp and shall be sized to provide _____ GPM @ _____ Ft. w.g. total system head. The glycol solution shall be _____ % (ethylene or propylene) by volume.

The drycooler and pump package shall be designed for _____ Volt, _____ Phase, _____ Hertz main power supply.

(Note: See AboveAir Technologies' FluidCool™ indoor & outdoor glycol drycooler and PumpAll™ glycol pump packages engineering manuals for more information.)

Chilled Water Systems

MCC-()



The system shall be a compact 24" x 24" maximum foot-print indoor vertical floor mounted chilled water precision air conditioner.

The chilled water cooling coil shall be constructed of copper tubes and alumi-

num fins. Coil end-plates shall be hot dipped galvanized. The cooling coil shall be mounted in an insulated stainless steel condensate drain pan.

Chilled water flow shall be controlled by a factory installed 2-Way (2-POS, ON/OFF) control valve rated for a maximum 300 psig w.w.p.

(Note: 3-way, Modulating (0-10Vdc) & Higher Pressure valves are optionally available.)

Options

DX Air Cooled Condenser - Low Ambient Control

0°F Ambient - Fan Cycling (CCX, XP1 & XPU Models)

Fan cycling controls shall be factory installed to the direct drive condenser fan to allow for low ambient operation to 0°F.

-20°F Ambient - Variable Spd Fan (CCX, CCU, XP1 & XPU Models)

Variable fan speed head pressure controls (JCI P266 or Modulating EC) shall be factory installed to allow for low ambient operation to -20°F. Compressor cold start time delay relay and crankcase heater shall be factory installed with the -20°F low ambient control feature.

-30°F Flooded Condenser (All Condenser/ing Models)

A flooded condenser system shall be provided to allow for low ambient condenser operation to -30°F. The flooded system shall include a factory installed liquid refrigerant receiver and modulating head pressure control valve. Compressor cold start time delay relay and crankcase heater shall be factory installed with the -30°F low ambient control feature.

DX - Water / Glycol Cooled Head Pressure Control

DX - Water/Glycol Reg. Valves (Factory Installed!)



- 2-Way, 150 psig Reg. Valve
- 3-Way, 150 psig Reg. Valve
- 2-Way, 350 psig Reg. Valve
- 3-Way, 350 psig Reg. Valve

System head pressure shall be controlled by a factory provided ___-Way water / glycol regulating valve rated for ___ psig w.w.p.

Chilled Water Control Valves

Chilled Water Control Valves



Zone Valves, 2-Position ON/OFF:

- 2-Way, 300 psig (2-POS, ON/OFF, NC)
- 3-Way, 300 psig (2-POS, ON/OFF, NC)

Modulating Valves, 0-10Vdc:

(Requires MC-2000™)

- 2-Way, 300 psig (0-10Vdc, NC)
- 3-Way, 300 psig (0-10Vdc, NC)

A ___-way chilled water system control valve shall be factory installed within the air conditioning unit. The valve shall provide precision space cooling and/or dehumidification control. The valve shall be the 24 VAC, ___-Way, (2-Position ON/OFF or Modulating 0-10Vdc), normally closed type.

Hot Gas Bypass Systems

Hot Gas Bypass To Evap Inlet



Each refrigerant circuit shall be provided with a factory installed hot gas (discharge) bypass valve. The hot gas bypass valve shall be designed to supply hot gas to evaporator inlet as required to provide coil freeze-protection and capacity modulation under low load conditions

Hot Gas Bypass To Suction Line with Quench Valve

(XPU & CCU Remote Condensing Units 3rd Line Not Required!)



Each refrigerant circuit of the Split DX system shall be provided with a factory installed hot gas bypass system to include: hot gas (discharge) bypass;

desuperheating quench; and hot gas & quench solenoid valves. The hot gas bypass system shall be designed to supply hot gas and liquid refrigerant to the suction line as required to provide coil freeze-protection and capacity modulation under low load conditions. All hot gas bypass components shall be factory installed and shall not require additional field refrigerant lines on split DX systems.

Suction-Line Accumulator



Each refrigerant circuit shall be provided with a factory installed Suction-Line Accumulator to prevent liquid slugging of the compressor and excessive refrigerant dilution of the compressor oil during low load conditions. The accumulator shall return refrigerant and oil to the compressor at a sufficient rate to maintain both system operating efficiency and proper oil level. The accumulators shall be wrapped with 1/2" closed-cell neoprene insulation to prevent sweating.

CONTROL OPTIONS

MC-2000™, Advanced Temp/Humid Microprocessor Controller w/ Alarms & BMS Connection



The system shall be provided with a MC-2000™ advanced microprocessor based temperature and humidity controller with alarms.

Select Features/Benefits:

- 4x20 Character Liquid Crystal Alpha-numerical Display
- User Configurable
- Run-Time Hours
- Current Unit Mode Status
- Alarm Status
- Digital & Analog Inputs / Outputs
- Temperature Anticipation
- Remote Stop / Start Contact
- Summary Alarm Contact
- Automatic or Manual (selectable) Restart After Power Loss
- Sequential Load After Restart
- Recovery Delay
- Compressor Short Cycle Timers
- Cold Start Time Delay
- Security Password Access

- Self-Diagnostics
- Service Mode

Unit Status Display

The control system shall display current unit functions and room status (if applicable):

- Current Dry Bulb Temp Set Point
- Current Relative Humidity Set Point
- System ON/OFF
- Cooling
- Heating
- Humidifying
- Dehumidifying
- Reheating
- Actual Room DB Temperature
- Actual Room Relative Humidity

Alarm Conditions:

Alarm conditions activate an audible and visual indicator plus close a summary alarm dry contact connection. The control system shall alert to the following alarm conditions (if applicable):

- High Temperature
- Low Temperature
- High Humidity
- Low Humidity
- Sensor Failure
- Summary Failure
- Loss of Air Flow
- High Head Press
- Smoke Detection
- Firestat
- Leak Detection
- Sensor Failure
- Loss of Power
- Dirty Filter

Digital & Analog Control Inputs / Outputs:

The control system shall be capable of both digital (ON/OFF) and analog (proportional integral, PI) input and output control.

Select MC-2000 Options:

- Multi-Unit N+1 Sequencing
- BMS Communications Interface:
 - BACnet over MS/TP (RS485 Serial)
 - BACnet Over IP (Ethernet / EIA485)
 - ModBus RS485 Serial Connection

Heat / Reheat Options

HEAT OPTIONS

Electric Reheat/Heat



An electric heating system shall be factory installed to provide:

- Electric Heat Only during heat mode
- Electric Reheat to offset sensible cooling during the dehumidification mode and to provide heating during heat mode.

Heater elements shall be the low-watt density finned-tubular type. The heater shall be complete with individual heater stage starter/contactor and overheat safeties. Systems incorporating factory installed electric heaters shall require only single point power to the main unit power distribution. The electric heat shall have a capacity of _____ BTU/H and a KW rating of ___ KW, controlled in ___ stages.

SCR Fired Heat/Reheat
(0-100% Modulating 0-10Vdc)

The electric heat/reheat shall be controlled through a "zero firing" silicon control rectifier (SCR) with an extruded aluminum heat sink and solid state logic system to provide close dry bulb temperature control of the leaving conditioned air temperature. The electric heat shall have a capacity of _____ BTUH and a KW rating of ___ KW.

Hot Gas Reheat



The system shall be provided with a hot gas reheat coil with 3-way heat reclaim control valve. The hot gas reheat coil shall provide free-energy space neutral leaving air temperature by offsetting the sensible cooling during dx dehumidification operation.

(Note: When compressor is located in the remote condensing unit, the maximum allowable refrigerant run for systems with Hot Gas Reheat is 40 linear feet, including both horizontal and vertical refrigerant line components.)

Hot Water or Steam Heat Coil



A Hot Water (or Steam) Heating system shall be factory provided. The hot water (or steam) heating system shall be complete a factory installed aluminum fin, copper tube hot water coil and field installed 2-way motorized hot water (or steam rated) control valve. Hot water (or steam) shall be provided by a remote source at the specified flow rate, temperature and pressure. Piping specialties shall be field provided by others. The heating system shall have a rated capacity of _____ BTUH @ _____ GPM, _____ °F EWT (or @ _____ psig saturated steam.)

Humidification Options

Steam Humidification



An electrode steam canister type humidification system shall be factory installed within the air conditioning system. The humidifier shall be complete with disposable canister, steam distributor, fill and drain valve, air gap, automatic flush cycle, manual humidity output adjustment and field installed remote wall mounted humidistat. The humidifier shall have a maximum output capacity of _____ lbs/hr.

Accessories

Plenum Discharge Box
(UF - Up-Flow Units)



A 3-Way (or 2-Way, or 1-Way) plenum discharge box shall be provided for field installation to the top of the up-flow unit. The plenum box shall be insulated and powder-coat painted to match the color of the unit. The plenum box supply grilles shall be the double deflection type with vertical blades in the front, horizontal blades in the back; both individually adjustable and on 2/3" spacing; aluminum roll-formed blade with semi-airfoil design; pressure fit nylon pivot pins (rattle free & non-loosening) and an aluminum extruded frame with mechanically locked corners.

Floor Stand



A _____ inch nominal high (____ in to ____ in adj. range) floor stand shall be factory provided for field installation. The floor stand shall have adjustable legs with vibration isolation.

Turning Vanes

Turning vanes shall be factory provided with the floor stand to direct the discharge air either to the front or rear of the unit.

Condensate Pump
(Factory Installed - UpFlow)



A condensate pump shall be factory provided and installed within the indoor evaporator section (*Up-Flow Air Pattern Configurations*). The condensate pump shall be provided with dual internal float switches: one for pump operation initiation and the other for pump reservoir overflow safety.

(Note: Down-Flow unit Condensate Pump Option requires field installation of the pump outside of the A/C unit. A condensate pump fused power supply terminal connection shall be factory provided within the A/C unit evaporator.)

Main Power, Non-Fused Disconnect
(Remote Condensing Section)



The remote condensing unit (or condenser) shall be factory provided with a main power non-fused disconnect for field installation. The disconnect shall be NEMA rated for indoor or outdoor installation as required.

Remote Water-Leak Detector



A remote water-leak detector shall be factory provided for field installation. The remote water-leak detector shall be wired to shut down all A/C unit water producing functions upon sensing a water leak.

(Note: Cable Type Remote Water Detectors are also optionally available.)

Flow Switch - Condenser Water



A factory installed flow switch shall shut-down / lockout compressor operation prior to a high refrigerant pressure switch alarm upon sensing a loss or low

dx condenser water/glycol flow. The flow switch alarm shall be indicated both via MC-2000 microprocessor display and auxiliary dry-contact terminal connection.

Low Entering Condenser Water / Glycol Kit to 45°F EWT/EGT

A low enter condenser water/glycol kit shall be provided with liquid refrigerant receiver, compressor crankcase heater, insulated wrapped coaxial condenser and unit internal condenser water/glycol piping. The Low EWT/EGT kit shall allow for continued winter A/C operation when condenser source water/glycol drops below 65°F (down to 45°F).

Smoke Detector (Factory Installed)



A Smoke Detector shall be factory installed in the return air stream of the unit and wired to the A/C unit electrical control panel. The Smoke Detector shall shut-down all A/C system operations upon activation.

Firestat (Factory Installed)



A Firestat shall be factory installed in the return air stream of the unit and wired to the A/C unit electrical control panel. The Firestat shall shut-down all A/C system operations upon sensing a high return air temperature condition.

Hose Kits - Automatic



Condenser water/glycol hose kits shall be factory provided. Each kit shall include the piping specialties necessary to ensure a proper installation: a Hays 2500 Series Mesurflo Automatic Flow Control Valve, two 36" flexible hoses, ball

valves on the return and supply sides with P/T Ports, high flow "Y-ball" strainers for sizes 1/2"-2" and a manual air vent on the return. Hose materials shall be the reinforced and bonded EPDM rubber type with a temperature rating of 32°F to 225°F and a working pressure of 400 psig. Minimum burst pressure shall be four (4) times the working pressure at maximum rated temperature. The hoses shall have stainless steel braid over an EPDM liner. The "Y-Ball" strainers shall have a stainless steel 20 mesh screen that is easily accessible for cleaning without disconnecting the hoses.

Mounting Vibration Isolators

Rubber/Cork Anti-Vibration Pads:



Each indoor vertical floor mounted section shall be provided with a set of quantity four (4"x4"x7/8") Rubber/Cork Anti-Vibration Pad vibration mounting isolators.

Spring Mounting Isolators:



Each indoor vertical floor mounted section shall be provided with a set of quantity four adjustable spring vibration mounting isolators with non-skid neoprene acoustical isolation pads. Isolators shall be sized for the total distributive weight of the unit with a 1" deflection.

Compressor Sound Jacket



Each compressor shall be provided with a factory installed compressor sound jacket with a snap closure system for ease of removal and reinstallation. Sound jackets shall have a noise reduction coefficient (NRC) of 0.85 per ASTM (C423) and a sound transmission class/loss (STC) of 11 per ASTM E-90.

DX - Air Cooled, Cooling Capacities

| Nominal Size | | 4kW (1.0T) | 5kW (1.5T) | 7kW (2.0T) | 9kW (2.5T) | 11kW (3.0T) | |
|--|--|-------------------|-------------------|-------------------|-------------------|-------------------|---------------|
| Up-Flow Model: | | MCE & MCH-004*-UF | MCE & MCH-005*-UF | MCE & MCH-007*-UF | MCE & MCH-009*-UF | MCE & MCH-011*-UF | |
| AIR COOLED DX UP-FLOW RATED CFM | Std Airflow Rate | CFM (CMH) | 750 (1,274) | 1,050 (1,784) | 1,350 (2,294) | 1,650 (2,803) | 1,900 (3,228) |
| | Net Cooling Capacity MBH (kW) | | | | | | |
| | 85°F DB / 64.4°F WB, 52F DP, (29.4°C DB / 18°C WB) 32% RH | | | | | | |
| | Total | MBH (kW) | 16.8 (4.9) | 22.3 (6.5) | 27.6 (8.1) | 34.2 (10.0) | 39.9 (11.7) |
| | Sensible | MBH (kW) | 16.8 (4.9) | 22.3 (6.5) | 27.6 (8.1) | 34.2 (10.0) | 39.9 (11.7) |
| | Efficiency Rating | SCOP | 3.3 | 2.9 | 3.1 | 2.8 | 2.8 |
| | 75°F DB / 61°F WB, 52°F DP, (23.9°C DB / 16.1°C WB) 44.6% RH | | | | | | |
| | Total | MBH (kW) | 14.7 (4.3) | 19.3 (5.7) | 24.0 (7.0) | 29.9 (8.8) | --- |
| | Sensible | MBH (kW) | 14.7 (4.3) | 19.3 (5.7) | 24.0 (7.0) | 29.9 (8.8) | --- |
| | AIR COOLED DX UP-FLOW OPTIONAL CFM | Opt Airflow Rate | CFM (CMH) | 500 (850) | 750 (1,274) | 1,000 (1,699) | 1,250 (2,124) |
| 75°F DB / 62.5°F WB, 55.1°F DP, (23.9°C DB / 16.9°C WB) 50% RH | | | | | | | |
| Total | | MBH (kW) | 14.0 (4.1) | 18.8 (5.5) | 23.6 (6.9) | 29.9 (8.7) | 35.4 (10.4) |
| Sensible | | MBH (kW) | 12.1 (3.5) | 16.5 (4.8) | 21.3 (6.3) | 26.5 (7.8) | 31.8 (9.3) |
| 75°F DB / 61°F WB, 52°F DP, (23.9°C DB / 16.1°C WB) 44.6% RH | | | | | | | |
| Total | | MBH (kW) | 13.8 (4.1) | 18.5 (5.4) | 23.3 (6.8) | 29.4 (8.6) | 34.8 (10.2) |
| Sensible | | MBH (kW) | 12.6 (3.7) | 17.5 (5.1) | 22.8 (6.7) | 28.4 (8.3) | 34.0 (10.0) |
| 72°F DB / 60°F WB, 52°F DP, (22.2°C DB / 15.6°C WB) 50% RH | | | | | | | |
| Total | | MBH (kW) | 13.4 (3.9) | 17.9 (5.3) | 22.6 (6.6) | 28.5 (8.4) | 33.9 (9.9) |
| Sensible | | MBH (kW) | 11.8 (3.5) | 16.1 (4.7) | 20.9 (6.1) | 25.8 (7.6) | 31.2 (9.2) |
| Down-Flow Model: | | MCE & MCH-004*-UF | MCE & MCH-005*-UF | MCE & MCH-007*-UF | MCE & MCH-009*-UF | MCE & MCH-011*-UF | |
| AIR COOLED DX DOWN-FLOW RATED CFM | Std Airflow Rate | CFM (CMH) | 750 (1,274) | 1,050 (1,784) | 1,350 (2,294) | 1,650 (2,803) | 1,900 (3,228) |
| | Net Cooling Capacity MBH (kW) | | | | | | |
| | 85°F DB / 64.4°F WB, 52F DP, (29.4°C DB / 18°C WB) 32% RH | | | | | | |
| | Total | MBH (kW) | 16.8 (4.9) | 22.4 (6.6) | 27.7 (8.1) | 34.3 (10.1) | 40.0 (11.7) |
| | Sensible | MBH (kW) | 16.8 (4.9) | 22.4 (6.6) | 27.7 (8.1) | 34.3 (10.1) | 40.0 (11.7) |
| | Efficiency Rating | SCOP | 3.3 | 3.0 | 3.1 | 2.8 | 2.8 |
| | 75°F DB / 61°F WB, 52°F DP, (23.9°C DB / 16.1°C WB) 44.6% RH | | | | | | |
| | Total | MBH (kW) | 14.7 (4.3) | 19.4 (5.7) | 24.1 (7.1) | 30.0 (8.8) | --- |
| | Sensible | MBH (kW) | 14.7 (4.3) | 19.4 (5.7) | 24.1 (7.1) | 30.0 (8.8) | --- |
| | AIR COOLED DX DOWN-FLOW OPTIONAL CFM | Opt Airflow Rate | CFM (CMH) | 500 (850) | 750 (1,274) | 1,000 (1,699) | 1,250 (2,124) |
| 75°F DB / 62.5°F WB, 55.1°F DP, (23.9°C DB / 16.9°C WB) 50% RH | | | | | | | |
| Total | | MBH (kW) | 14.1 (4.1) | 18.8 (5.5) | 23.6 (6.9) | 29.9 (8.8) | 35.5 (10.4) |
| Sensible | | MBH (kW) | 12.1 (3.5) | 16.6 (4.9) | 21.4 (6.3) | 26.6 (7.8) | 31.9 (9.4) |
| 75°F DB / 61°F WB, 52°F DP, (23.9°C DB / 16.1°C WB) 44.6% RH | | | | | | | |
| Total | | MBH (kW) | 13.9 (4.1) | 18.5 (5.4) | 23.3 (6.8) | 29.5 (8.6) | 34.9 (10.2) |
| Sensible | | MBH (kW) | 12.7 (3.7) | 17.5 (5.1) | 22.9 (6.7) | 28.5 (8.4) | 34.1 (10.0) |
| 72°F DB / 60°F WB, 52°F DP, (22.2°C DB / 15.6°C WB) 50% RH | | | | | | | |
| Total | | MBH (kW) | 13.4 (3.9) | 18.0 (5.3) | 22.6 (6.6) | 28.6 (8.4) | 34.0 (10.0) |
| Sensible | | MBH (kW) | 11.9 (3.5) | 16.1 (4.7) | 21.0 (6.2) | 25.9 (7.6) | 31.3 (9.2) |

DX - Water Cooled, Cooling Capacities

| Nominal Size | 4kW (1.0T) | 5kW (1.5T) | 7kW (2.0T) | 9kW (2.5T) | 11kW (3.0T) |
|-----------------------|--------------------|--------------------|--------------------|--------------------|--------------------|
| Up-Flow Model: | MCW-004*-UF | MCW-005*-UF | MCW-007*-UF | MCW-009*-UF | MCW-011*-UF |

| | | | | | | | |
|--|--|------------------|--------------------|----------------------|----------------------|----------------------|----------------------|
| WATER COOLED DX UP-FLOW RATED CFM | Std Airflow Rate | CFM (CMH) | 750 (1,274) | 1,050 (1,784) | 1,350 (2,294) | 1,650 (2,803) | 1,900 (3,228) |
| | Net Cooling Capacity MBH (kW) | | | | | | |
| | 85°F DB / 64.4°F WB, 52F DP, (29.4°C DB / 18°C WB) 32% RH | | | | | | |
| | Total | MBH (kW) | 18.2 (5.3) | 25.0 (7.3) | 30.4 (8.9) | 37.6 (11.0) | 42.2 (12.4) |
| | Sensible | MBH (kW) | 18.2 (5.3) | 25.0 (7.3) | 30.4 (8.9) | 37.6 (11.0) | 42.2 (12.4) |
| | Efficiency Rating | SCOP | 3.6 | 3.4 | 3.5 | 3.2 | 3.1 |
| | 75°F DB / 61°F WB, 52°F DP, (23.9°C DB / 16.1°C WB) 44.6% RH | | | | | | |
| | Total | MBH (kW) | 16.0 (4.7) | 22.0 (6.4) | 26.6 (7.8) | 31.9 (9.4) | --- |
| | Sensible | MBH (kW) | 16.0 (4.7) | 22.0 (6.4) | 26.6 (7.8) | 31.9 (9.4) | --- |

| | | | | | | | |
|---|--|------------------|------------------|--------------------|----------------------|----------------------|----------------------|
| WATER COOLED DX UP-FLOW OPTIONAL CFM | Opt Airflow Rate | CFM (CMH) | 500 (850) | 750 (1,274) | 1,000 (1,699) | 1,250 (2,124) | 1,600 (2,718) |
| | 75°F DB / 62.5°F WB, 55.1°F DP, (23.9°C DB / 16.9°C WB) 50% RH | | | | | | |
| | Total | MBH (kW) | 15.2 (4.5) | 21.3 (6.3) | 26.0 (7.6) | 32.9 (9.7) | 37.4 (11.0) |
| | Sensible | MBH (kW) | 12.6 (3.7) | 17.7 (5.2) | 22.4 (6.6) | 27.9 (8.2) | 32.7 (9.6) |
| | 75°F DB / 61°F WB, 52°F DP, (23.9°C DB / 16.1°C WB) 44.6% RH | | | | | | |
| | Total | MBH (kW) | 15.0 (4.4) | 21.0 (6.1) | 25.6 (7.5) | 32.3 (9.5) | 36.8 (10.8) |
| | Sensible | MBH (kW) | 13.5 (3.9) | 18.8 (5.5) | 24.0 (7.0) | 29.8 (8.7) | 35.0 (10.3) |
| | 72°F DB / 60°F WB, 52°F DP, (22.2°C DB / 15.6°C WB) 50% RH | | | | | | |
| | Total | MBH (kW) | 14.6 (4.3) | 20.4 (6.0) | 24.9 (7.3) | 31.5 (9.2) | 35.8 (10.5) |
| | Sensible | MBH (kW) | 12.3 (3.6) | 17.3 (5.1) | 21.9 (6.4) | 27.3 (8.0) | 31.9 (9.3) |

| | | | | | |
|-------------------------|--------------------|--------------------|--------------------|--------------------|--------------------|
| Down-Flow Model: | MCW-004*-DF | MCW-005*-DF | MCW-007*-DF | MCW-009*-DF | MCW-011*-DF |
|-------------------------|--------------------|--------------------|--------------------|--------------------|--------------------|

| | | | | | | | |
|--|--|------------------|--------------------|----------------------|----------------------|----------------------|----------------------|
| WATER COOLED DX DOWN-FLOW RATED CFM | Std Airflow Rate | CFM (CMH) | 750 (1,274) | 1,050 (1,784) | 1,350 (2,294) | 1,650 (2,803) | 1,900 (3,228) |
| | Net Cooling Capacity MBH (kW) | | | | | | |
| | 85°F DB / 64.4°F WB, 52F DP, (29.4°C DB / 18°C WB) 32% RH | | | | | | |
| | Total | MBH (kW) | 18.3 (5.4) | 25.1 (7.4) | 30.4 (8.9) | 37.7 (11.1) | 42.3 (12.4) |
| | Sensible | MBH (kW) | 18.3 (5.4) | 25.1 (7.4) | 30.4 (8.9) | 37.7 (11.1) | 42.3 (12.4) |
| | Efficiency Rating | SCOP | 3.6 | 3.4 | 3.5 | 3.3 | 3.1 |
| | 75°F DB / 61°F WB, 52°F DP, (23.9°C DB / 16.1°C WB) 44.6% RH | | | | | | |
| | Total | MBH (kW) | 16.0 (4.7) | 22.1 (6.5) | 26.7 (7.8) | 33.2 (9.7) | --- |
| | Sensible | MBH (kW) | 16.0 (4.7) | 22.1 (6.5) | 26.7 (7.8) | 33.2 (9.7) | --- |

| | | | | | | | |
|---|--|------------------|------------------|--------------------|----------------------|----------------------|----------------------|
| WATER COOLED DX DOWN-FLOW OPTIONAL CFM | Opt Airflow Rate | CFM (CMH) | 500 (850) | 750 (1,274) | 1,000 (1,699) | 1,250 (2,124) | 1,600 (2,718) |
| | 75°F DB / 62.5°F WB, 55.1°F DP, (23.9°C DB / 16.9°C WB) 50% RH | | | | | | |
| | Total | MBH (kW) | 15.3 (4.5) | 21.4 (6.3) | 26.1 (7.6) | 33.0 (9.7) | 37.5 (11.0) |
| | Sensible | MBH (kW) | 12.6 (3.7) | 17.7 (5.2) | 22.5 (6.6) | 28.0 (8.2) | 32.8 (9.6) |
| | 75°F DB / 61°F WB, 52°F DP, (23.9°C DB / 16.1°C WB) 44.6% RH | | | | | | |
| | Total | MBH (kW) | 15.0 (4.4) | 21.0 (6.2) | 25.7 (7.5) | 32.4 (9.5) | 36.9 (10.8) |
| | Sensible | MBH (kW) | 13.5 (4.0) | 18.9 (5.5) | 24.1 (7.0) | 29.9 (8.8) | 35.1 (10.3) |
| | 72°F DB / 60°F WB, 52°F DP, (22.2°C DB / 15.6°C WB) 50% RH | | | | | | |
| | Total | MBH (kW) | 14.6 (4.3) | 20.4 (6.0) | 25.0 (7.3) | 31.6 (9.3) | 35.9 (10.5) |
| | Sensible | MBH (kW) | 12.4 (3.6) | 17.3 (5.1) | 22.0 (6.4) | 27.4 (8.0) | 32.0 (9.4) |

DX - Glycol Cooled, Cooling Capacities

| Nominal Size | 4kW (1.0T) | 5kW (1.5T) | 7kW (2.0T) | 9kW (2.5T) | 11kW (3.0T) |
|-----------------------|---------------------|---------------------|---------------------|---------------------|---------------------|
| Up-Flow Model: | MCG-004-*-UF | MCG-005-*-UF | MCG-007-*-UF | MCG-009-*-UF | MCG-011-*-UF |

| | | | | | | | | |
|---|--|------------------|--------------------|----------------------|----------------------|----------------------|----------------------|--|
| GLYCOL COOLED DX UP-FLOW RATED CFM | Std Airflow Rate | CFM (CMH) | 750 (1,274) | 1,050 (1,784) | 1,350 (2,294) | 1,650 (2,803) | 1,900 (3,228) | |
| | Net Cooling Capacity MBH (kW) | | | | | | | |
| | 85°F DB / 64.4°F WB, 52°F DP, (29.4°C DB / 18°C WB) 32% RH | | | | | | | |
| | Total | MBH (kW) | 16.8 (4.9) | 23.8 (7.0) | 27.4 (8.0) | 35.0 (10.3) | 39.9 (11.7) | |
| | Sensible | MBH (kW) | 16.8 (4.9) | 23.8 (7.0) | 27.4 (8.0) | 35.0 (10.3) | 39.9 (11.7) | |
| | Efficiency Rating | SCOP | 2.7 | 2.7 | 2.6 | 2.5 | 2.5 | |
| | 75°F DB / 61°F WB, 52°F DP, (23.9°C DB / 16.1°C WB) 44.6% RH | | | | | | | |
| | Total | MBH (kW) | 14.7 (4.3) | 20.8 (6.1) | 23.9 (7.0) | 30.6 (9.0) | --- | |
| | Sensible | MBH (kW) | 14.7 (4.3) | 20.8 (6.1) | 23.9 (7.0) | 30.6 (9.0) | --- | |

| | | | | | | | | |
|--|--|------------------|------------------|--------------------|----------------------|----------------------|----------------------|--|
| GLYCOL COOLED DX UP-FLOW OPTIONAL CFM | Opt Airflow Rate | CFM (CMH) | 500 (850) | 750 (1,274) | 1,000 (1,699) | 1,250 (2,124) | 1,600 (2,718) | |
| | 75°F DB / 62.5°F WB, 55.1°F DP, (23.9°C DB / 16.9°C WB) 50% RH | | | | | | | |
| | Total | MBH (kW) | 13.2 (3.9) | 18.3 (5.4) | 22.2 (6.5) | 28.0 (8.2) | 31.4 (9.2) | |
| | Sensible | MBH (kW) | 11.7 (3.4) | 16.3 (4.8) | 20.6 (6.0) | 25.5 (7.5) | 29.0 (8.5) | |
| | 75°F DB / 61°F WB, 52°F DP, (23.9°C DB / 16.1°C WB) 44.6% RH | | | | | | | |
| | Total | MBH (kW) | 13.0 (3.8) | 18.1 (5.3) | 21.9 (6.4) | 27.6 (8.1) | 31.4 (9.2) | |
| | Sensible | MBH (kW) | 12.2 (3.6) | 17.3 (5.1) | 21.9 (6.4) | 27.2 (8.0) | 31.4 (9.2) | |
| | 72°F DB / 60°F WB, 52°F DP, (22.2°C DB / 15.6°C WB) 50% RH | | | | | | | |
| | Total | MBH (kW) | 12.6 (3.7) | 17.5 (5.1) | 21.2 (6.2) | 26.8 (7.8) | 30.1 (8.8) | |
| | Sensible | MBH (kW) | 11.5 (3.4) | 15.9 (4.7) | 20.0 (5.9) | 24.9 (7.3) | 28.2 (8.3) | |

| | | | | | |
|-------------------------|---------------------|---------------------|---------------------|---------------------|---------------------|
| Down-Flow Model: | MCG-004-*-DF | MCG-005-*-DF | MCG-007-*-DF | MCG-009-*-DF | MCG-011-*-DF |
|-------------------------|---------------------|---------------------|---------------------|---------------------|---------------------|

| | | | | | | | | |
|---|--|------------------|--------------------|----------------------|----------------------|----------------------|----------------------|--|
| GLYCOL COOLED DX DOWN-FLOW RATED CFM | Std Airflow Rate | CFM (CMH) | 750 (1,274) | 1,050 (1,784) | 1,350 (2,294) | 1,650 (2,803) | 1,900 (3,228) | |
| | Net Cooling Capacity MBH (kW) | | | | | | | |
| | 85°F DB / 64.4°F WB, 52°F DP, (29.4°C DB / 18°C WB) 32% RH | | | | | | | |
| | Total | MBH (kW) | 16.8 (4.9) | 23.9 (7.0) | 27.5 (8.1) | 35.1 (10.3) | 40.1 (11.8) | |
| | Sensible | MBH (kW) | 16.8 (4.9) | 23.9 (7.0) | 27.5 (8.1) | 35.1 (10.3) | 40.1 (11.8) | |
| | Efficiency Rating | SCOP | 2.8 | 2.8 | 2.6 | 2.6 | 2.6 | |
| | 75°F DB / 61°F WB, 52°F DP, (23.9°C DB / 16.1°C WB) 44.6% RH | | | | | | | |
| | Total | MBH (kW) | 14.7 (4.3) | 20.9 (6.1) | 23.9 (7.0) | 30.7 (9.0) | --- | |
| | Sensible | MBH (kW) | 14.7 (4.3) | 20.9 (6.1) | 23.9 (7.0) | 30.7 (9.0) | --- | |

| | | | | | | | | |
|--|--|------------------|------------------|--------------------|----------------------|----------------------|----------------------|--|
| GLYCOL COOLED DX DOWN-FLOW OPTIONAL CFM | Opt Airflow Rate | CFM (CMH) | 500 (850) | 750 (1,274) | 1,000 (1,699) | 1,250 (2,124) | 1,600 (2,718) | |
| | 75°F DB / 62.5°F WB, 55.1°F DP, (23.9°C DB / 16.9°C WB) 50% RH | | | | | | | |
| | Total | MBH (kW) | 13.3 (3.9) | 18.4 (5.4) | 22.3 (6.5) | 28.1 (8.2) | 31.5 (9.2) | |
| | Sensible | MBH (kW) | 11.8 (3.5) | 16.4 (4.8) | 20.7 (6.1) | 25.6 (7.5) | 29.1 (8.5) | |
| | 75°F DB / 61°F WB, 52°F DP, (23.9°C DB / 16.1°C WB) 44.6% RH | | | | | | | |
| | Total | MBH (kW) | 13.1 (3.8) | 18.1 (5.3) | 22.0 (6.4) | 27.7 (8.1) | 31.5 (9.2) | |
| | Sensible | MBH (kW) | 12.3 (3.6) | 17.3 (5.1) | 21.9 (6.4) | 27.3 (8.0) | 31.5 (9.2) | |
| | 72°F DB / 60°F WB, 52°F DP, (22.2°C DB / 15.6°C WB) 50% RH | | | | | | | |
| | Total | MBH (kW) | 12.7 (3.7) | 17.5 (5.1) | 21.3 (6.2) | 26.9 (7.9) | 30.2 (8.8) | |
| | Sensible | MBH (kW) | 11.5 (3.4) | 15.9 (4.7) | 20.1 (5.9) | 25.0 (7.3) | 28.3 (8.3) | |

DX - Heat Rejection Data - MC2x2 (4-11kW, 1-3 Tons)

DX - Heat Rejection Data

| Nominal Size | 4kW (1.0T) | 5kW (1.5T) | 7kW (2.0T) | 9kW (2.5T) | 11kW (3.0T) |
|-----------------------|---------------|---------------|---------------|---------------|---------------|
| DX - Air Cooled Model | MCE & MCH-004 | MCE & MCH-005 | MCE & MCH-007 | MCE & MCH-009 | MCE & MCH-011 |

DX - AIR COOLED CONDENSER / CONDENSING UNIT DATA - 95°F AMBIENT

| Outdoor, Remote Propeller Fan Air Cooled Condensing Units & Condensers - (XPU & XP1 models) | | | | | | |
|--|---------------|------------------|------------------|------------------|------------------|------------------|
| Remote Condensing Unit Model | TXT | XPU-004S | XPU-005S | XPU-007S | XPU-009S | XPU-011S |
| Remote Condenser Model | TXT | XP1-004S | XP1-005S | XP1-007S | XP1-009S | XP1-011S |
| Airflow Rate (208/277-1) | CFM (CMH) | 1,600 (2,718) | 1,881 (3,196) | 2,614 (4,441) | 3,310 (5,624) | 3,167 (5,381) |
| Airflow Rate (208/460-3 & 460-1) | CFM (CMH) | N/A | N/A | 2,218 (3,768) | 2,954 (5,019) | 3,700 (6,286) |
| E.S.P. | IN WG | Free Discharge | Free Discharge | Free Discharge | Free Discharge | Free Discharge |
| Fan Motor (Qty.) HP | HP (kW) | 1/6 | 1/6 | 1/4 | 1/4 | 1/4 |
| Blower / Motor Qty. | NO | One | One | One | One | One |
| Blower Type | TXT | DD - Axial | DD - Axial | DD - Axial | DD - Axial | DD - Axial |
| Rows / Face Area | NO / FT2 (m2) | 1 / 8.40 (0.78) | 1 / 9.90 (0.92) | 1 / 9.80 (0.91) | 1 / 13.13 (1.22) | 1 / 17.25 (1.6) |
| Indoor, Remote Centrifugal Blower Air Cooled Condenser & Condensing Unit Data - (CCU & CCX Models) | | | | | | |
| Remote Condensing Unit Model | TXT | CCU-004S-_C | CCU-005S-_C | CCU-007S-_C | CCU-009S-_C | CCU-011S-_C |
| Remote Condenser Model | TXT | CCX-004S-_C | CCX-005S-_C | CCX-007S-_C | CCX-009S-_C | CCX-011S-_C |
| Airflow Rate | CFM | 1,000 | 1,200 | 1,400 | 1,700 | 1,700 |
| E.S.P. | IN WG | 0.3 | 0.3 | 0.3 | 0.3 | 0.3 |
| Std PSC Blower Motor | HP | 1/2 | 1/2 | 3/4 | 3/4 | 3/4 |
| Opt ECM Blower Motor | HP | 1/2 | 1/2 | 3/4 | 3/4 | 3/4 |
| Blower / Motor Qty. | NO | One | One | One | One | One |
| Blower Type | TXT | DD - Centrifugal | DD - Centrifugal | DD - Centrifugal | DD - Centrifugal | DD - Centrifugal |
| Rows / Face Area | NO / FT2 | 4 / 2.0 | 4 / 2.0 | 4 / 2.5 | 4 / 2.5 | 4 / 2.5 |

AIR COOLED DX

DX - WATER COOLED CONDENSER DATA

| Nominal Size | 4kW (1.0T) | 5kW (1.5T) | 7kW (2.0T) | 9kW (2.5T) | 11kW (3.0T) |
|-------------------------|------------|------------|------------|------------|-------------|
| DX - Water Cooled Model | MCW-004 | MCW-005 | MCW-007 | MCW-009 | MCW-011 |

| Water Cooled Condenser Data - 85°F EWT / 95°F LWT, 0% Glycol Solution (rated at 75°F DB/62.5°F WB EAT Cooling Performance) | | | | | | |
|--|-------------|--|------------|------------|-------------|-------------|
| Total Heat of Rej. | MBH (kW) | 17.7 (5.2) | 25.3 (7.4) | 30.6 (9.0) | 39.5 (11.6) | 45.6 (13.4) |
| Flow 85°F EWT | GPM (l/m) | 3.4 (12.9) | 4.7 (17.8) | 5.7 (21.6) | 6.8 (25.8) | 8.7 (33.0) |
| Fluid Pressure Drop | FT WG (kPa) | 7.6 (22.7) | 7.3 (21.8) | 7.3 (21.8) | 9.9 (29.5) | 9.5 (28.4) |
| Condenser Type | TXT | Coaxial | Coaxial | Coaxial | Coaxial | Coaxial |
| Water Reg. Valve | TXT | 2-Way, 150 psig - factory installed, (3-way & High Pressure Valves are Optional) | | | | |
| Valve Size, (Cv) | IN (NO) | 1/2 (4.7) | 1/2 (4.7) | 3/4 (7.4) | 3/4 (7.4) | 3/4 (7.4) |

WATER COOLED DX

DX - GLYCOL COOLED CONDENSER DATA

| Nominal Size | 4kW (1.0T) | 5kW (1.5T) | 7kW (2.0T) | 9kW (2.5T) | 11kW (3.0T) |
|--------------------------|------------|------------|------------|------------|-------------|
| DX - Glycol Cooled Model | MCG-004 | MCG-005 | MCG-007 | MCG-009 | MCG-011 |

| Glycol Cooled Condenser Data - 110°F EWT / 120°F LWT, 40% Glycol Solution (rated at 75°F DB/62.5°F WB EAT Cooling Performance) | | | | | | |
|--|-------------|--|-------------|------------|-------------|-------------|
| Total Heat of Rej. | MBH (kW) | 16.6 (4.9) | 23.9 (7.0) | 28.2 (8.3) | 36.9 (10.8) | 42.4 (12.4) |
| Flow 110°F EGT, 40% EG | GPM (l/m) | 3.4 (12.9) | 5.2 (19.7) | 5.7 (21.6) | 7.0 (26.5) | 8.7 (33.0) |
| Fluid Pressure Drop | FT WG (kPa) | 9.3 (28.9) | 10.7 (33.3) | 8.9 (27.7) | 12.8 (39.8) | 11.6 (36.1) |
| Condenser Type | TXT | Coaxial | Coaxial | Coaxial | Coaxial | Coaxial |
| Glycol Reg. Valve | TXT | 2-Way, 150 psig - factory installed, (3-way & High Pressure Valves are Optional) | | | | |
| Valve Size, (Cv) | IN (NO) | 1/2 (4.7) | 1/2 (4.7) | 3/4 (7.4) | 3/4 (7.4) | 3/4 (7.4) |

GLYCOL COOLED DX

Connection Data

| DX - Split Evaporators & Indoor Centrifugal Blower Remote Air Cooled Condensers - (MCE & CCX models) | | | | | | |
|--|-------|---------|---------|---------|---------|---------|
| Liquid Line | OD IN | (1) 3/8 | (1) 3/8 | (1) 3/8 | (1) 3/8 | (1) 3/8 |
| Hot Gas Line | OD IN | (1) 1/2 | (1) 1/2 | (1) 1/2 | (1) 1/2 | (1) 1/2 |
| DX - Outdoor, Axial Fan Remote Air Cooled Condensers/ing Units - (XP1 w/ Liq. & Hot Gas Lines and XPU w/ Liq. & Suction Lines) | | | | | | |
| Liquid Line | OD IN | (1) 3/8 | (1) 3/8 | (1) 3/8 | (1) 3/8 | (1) 3/8 |
| Suct. or HG Line | OD IN | (1) 3/4 | (1) 3/4 | (1) 3/4 | (1) 7/8 | (1) 7/8 |
| DX - Split Air Handling Units & Indoor, Centrifugal Blower Remote Air Cooled Condensing Units - (MCH & CCU models) | | | | | | |
| Liquid Line | OD IN | (1) 3/8 | (1) 3/8 | (1) 3/8 | (1) 3/8 | (1) 3/8 |
| Suction Line | OD IN | (1) 3/4 | (1) 3/4 | (1) 3/4 | (1) 7/8 | (1) 7/8 |
| DX - Water / Glycol Cooled | | | | | | |
| Condenser Water/Glycol IN/OUT | OD IN | 5/8 | 5/8 | 7/8 | 7/8 | 7/8 |

ALL DX SYSTEMS

Cooling Capacity Data - MC2x2, Chilled Water Systems (4-11kW, 1-3 Tons)

Chilled Water System, Cooling Capacities

| Nominal Size | | 4kW (1.0T) | 5kW (1.5T) | 7kW (2.0T) | 9kW (2.5T) | 11kW (3.0T) | |
|---|---|------------------------------------|---|---------------|---------------|---------------|---------------|
| Up-Flow Model: | | MCC-004-*-UF | MCC-005-*-UF | MCC-007-*-UF | MCC-009-*-UF | MCC-011-*-UF | |
| CHILLED WATER SYSTEMS 45°F EWT 55°F LWT UP-FLOW STD CFM | Std Airflow Rate | CFM (CMH) | 750 (1,274) | 1,050 (1,784) | 1,350 (2,294) | 1,650 (2,803) | 1,900 (3,228) |
| | Net Cooling Capacity MBH (kW) | | | | | | |
| | 85°F DB / 64.4°F WB, 52F DP, (29.4°C DB / 18°C WB) 32% RH | | | | | | |
| | Total | MBH (kW) | 23.5 (6.9) | 30.4 (8.9) | 36 (10.6) | 49.6 (14.5) | 54.7 (16.0) |
| | Sensible | MBH (kW) | 23.0 (6.7) | 30.4 (8.9) | 36 (10.6) | 49.6 (14.5) | 54.7 (16.0) |
| | Flow Rate, (Coil PD) | GPM / FT WG | 4.8 / 3.4 | 6.2 / 5.5 | 7.4 / 7.7 | 8.6 / 10.1 | 9.5 / 12.2 |
| | 75°F DB / 62.5°F WB, 55.1°F DP, (23.9°C DB / 16.9°C WB) 50% RH | | | | | | |
| | Total | MBH (kW) | 18.4 (5.4) | 23.2 (6.8) | 26.9 (7.9) | 37.9 (11.1) | --- |
| | Sensible | MBH (kW) | 15.7 (4.6) | 20.5 (6.0) | 24.4 (7.2) | 33.1 (9.7) | --- |
| | Flow Rate, (Coil PD) | GPM / FT WG | 3.8 / 2.2 | 4.7 / 3.3 | 5.6 / 4.6 | 6.4 / 5.9 | --- |
| | 72°F DB / 60°F WB, 52°F DP, (22.2°C DB / 15.6°C WB) 50% RH | | | | | | |
| | Total | MBH (kW) | 12.7 (3.7) | 18.9 (5.5) | 21.8 (6.4) | 30.6 (9.0) | --- |
| | Sensible | MBH (kW) | 12.7 (3.7) | 18.8 (5.5) | 21.8 (6.4) | 30.2 (8.9) | --- |
| | Flow Rate, (Coil PD) | GPM / FT WG | 2.6 / 1.1 | 3.9 / 2.3 | 4.6 / 3.2 | 5.3 / 4.1 | --- |
| | CHILLED WATER SYSTEMS 45°F EWT 55°F LWT UP-FLOW OPT CFM | Opt Airflow Rate | CFM (CMH) | 500 (850) | 750 (1,274) | 1,000 (1,699) | 1,250 (2,124) |
| Net Cooling Capacity MBH (kW) | | | | | | | |
| 75°F DB / 62.5°F WB, 55.1°F DP, (23.9°C DB / 16.9°C WB) 50% RH | | | | | | | |
| Total | | MBH (kW) | 11.5 (3.4) | 18.4 (5.4) | 22.5 (6.6) | 31.3 (9.2) | 37 (10.8) |
| Sensible | | MBH (kW) | 10.3 (3.0) | 15.7 (4.6) | 19.8 (5.8) | 26.5 (7.8) | 32.2 (9.4) |
| Flow Rate, (Coil PD) | | GPM / FT WG | 2.4 / 1.0 | 3.8 / 2.2 | 4.6 / 3.2 | 5.3 / 4.1 | 6.3 / 5.7 |
| 75°F DB / 61°F WB, 52°F DP, (23.9°C DB / 16.1°C WB) 44.6% RH | | | | | | | |
| Total | | MBH (kW) | 10.5 (3.1) | 16.7 (4.9) | 20.9 (6.1) | 28.7 (8.4) | 34.4 (10.1) |
| Sensible | | MBH (kW) | 10.5 (3.1) | 16.2 (4.7) | 20.8 (6.1) | 27.6 (8.1) | 33.9 (9.9) |
| Flow Rate, (Coil PD) | | GPM / FT WG | 2.2 / 0.8 | 3.4 / 1.8 | 4.3 / 2.8 | 5.0 / 3.7 | 5.9 / 5.0 |
| 72°F DB / 60°F WB, 52°F DP, (22.2°C DB / 15.6°C WB) 50% RH | | | | | | | |
| Total | | MBH (kW) | 9.1 (2.7) | 12.7 (3.7) | 18.1 (5.3) | 25.2 (7.4) | 30.2 (8.9) |
| Sensible | | MBH (kW) | 9.1 (2.7) | 12.7 (3.7) | 18.0 (5.3) | 24.0 (7.0) | 29.4 (8.6) |
| Flow Rate, (Coil PD) | | GPM / FT WG | 1.9 / 0.5 | 2.6 / 1.1 | 3.7 / 2.1 | 4.4 / 2.9 | 5.2 / 4.0 |
| CHILLED WATER SYSTEMS 45°F EWT 55°F LWT DOWN-FLOW STD CFM | | Down-Flow Model: | | MCC-004-*-DF | MCC-005-*-DF | MCC-007-*-DF | MCC-009-*-DF |
| | Std Airflow Rate | CFM (CMH) | 750 (1,274) | 1,050 (1,784) | 1,350 (2,294) | 1,650 (2,803) | 1,900 (3,228) |
| | Net Cooling Capacity MBH (kW) | | | | | | |
| | 85°F DB / 64.4°F WB, 52F DP, (29.4°C DB / 18°C WB) 32% RH | | | | | | |
| | Total | MBH (kW) | 23.6 (6.9) | 30.5 (8.9) | 36.0 (10.6) | 49.7 (14.6) | 54.9 (16.1) |
| | Sensible | MBH (kW) | 23.1 (6.8) | 30.5 (8.9) | 36.0 (10.6) | 49.7 (14.6) | 54.9 (16.1) |
| | Flow Rate, (Coil PD) | GPM / FT WG | 4.8 / 3.4 | 6.2 / 5.5 | 7.4 / 7.7 | 10.2 / 13.3 | 11.3 / 16.0 |
| | 75°F DB / 62.5°F WB, 55.1°F DP, (23.9°C DB / 16.9°C WB) 50% RH | | | | | | |
| | Total | MBH (kW) | 18.5 (5.4) | 23.3 (6.8) | 27.0 (7.9) | 38.0 (11.1) | --- |
| | Sensible | MBH (kW) | 15.8 (4.6) | 20.6 (6.0) | 24.5 (7.2) | 33.2 (9.7) | --- |
| | Flow Rate, (Coil PD) | GPM / FT WG | 3.8 / 2.2 | 4.7 / 3.3 | 5.6 / 4.6 | 7.9 / 8.2 | --- |
| | 72°F DB / 60°F WB, 52°F DP, (22.2°C DB / 15.6°C WB) 50% RH | | | | | | |
| | Total | MBH (kW) | 12.8 (3.8) | 19.0 (5.6) | 21.9 (6.4) | 30.7 (9.0) | --- |
| | Sensible | MBH (kW) | 12.8 (3.8) | 18.8 (5.5) | 21.9 (6.4) | 30.2 (8.9) | --- |
| | Flow Rate, (Coil PD) | GPM / FT WG | 2.6 / 1.1 | 3.9 / 2.3 | 4.6 / 3.2 | 6.4 / 5.6 | --- |
| CHILLED WATER SYSTEMS 45°F EWT 55°F LWT DOWN-FLOW OPT CFM | Opt Airflow Rate | CFM (CMH) | 500 (850) | 750 (1,274) | 1,000 (1,699) | 1,250 (2,124) | 1,600 (2,718) |
| | Net Cooling Capacity MBH (kW) | | | | | | |
| | 75°F DB / 62.5°F WB, 55.1°F DP, (23.9°C DB / 16.9°C WB) 50% RH | | | | | | |
| | Total | MBH (kW) | 11.6 (3.4) | 18.5 (5.4) | 22.6 (6.6) | 31.4 (9.2) | 37.1 (10.9) |
| | Sensible | MBH (kW) | 10.3 (3.0) | 15.8 (4.6) | 19.8 (5.8) | 26.5 (7.8) | 32.3 (9.5) |
| | Flow Rate, (Coil PD) | GPM / FT WG | 2.4 / 1.0 | 3.8 / 2.2 | 4.6 / 3.2 | 6.5 / 5.7 | 7.7 / 7.9 |
| | 75°F DB / 61°F WB, 52°F DP, (23.9°C DB / 16.1°C WB) 44.6% RH | | | | | | |
| | Total | MBH (kW) | 10.6 (3.1) | 16.8 (4.9) | 20.9 (6.1) | 28.8 (8.4) | 34.5 (10.1) |
| | Sensible | MBH (kW) | 10.6 (3.1) | 16.3 (4.8) | 20.8 (6.1) | 27.7 (8.1) | 34.0 (10.0) |
| | Flow Rate, (Coil PD) | GPM / FT WG | 2.2 / 0.8 | 3.4 / 1.8 | 4.3 / 2.8 | 6.0 / 4.9 | 7.2 / 6.9 |
| | 72°F DB / 60°F WB, 52°F DP, (22.2°C DB / 15.6°C WB) 50% RH | | | | | | |
| | Total | MBH (kW) | 9.2 (2.7) | 12.8 (3.8) | 18.2 (5.3) | 25.3 (7.4) | 30.2 (8.9) |
| | Sensible | MBH (kW) | 9.2 (2.7) | 12.8 (3.8) | 18.1 (5.3) | 24.1 (7.1) | 29.5 (8.6) |
| | Flow Rate, (Coil PD) | GPM / FT WG | 1.9 / 0.5 | 2.6 / 1.1 | 3.7 / 2.1 | 5.3 / 3.9 | 6.4 / 5.6 |
| | VALVE DATA | Chilled Water Control Valve | | | | | |
| Standard Valve | | TX | 2-Way (2-POS, ON/OFF) - Factory Installed | | | | |
| Valve Size, (Cv) | | IN (NO) | 1/2 (4.0) | 1/2 (4.0) | 3/4 (7.5) | 3/4 (7.5) | 3/4 (7.5) |
| Optional Valve | | TX | 3-Way (2-POS, ON/OFF), 2 or 3-Way Modulating (0-10 VDC) - Factory Installed | | | | |
| Chilled Water IN/OUT | | OD IN | 5/8 | 5/8 | 7/8 | 7/8 | 7/8 |

Performance Data

Physical Data - All Systems

| Nominal Size | | 4kW (1.0T) | 5kW (1.5T) | 7kW (2.0T) | 9kW (2.5T) | 11kW (3.0T) |
|--|---------------|--|------------------------------------|------------------------------------|------------------------------------|------------------------------------|
| MC 2x2 Model Size | | 004 | 005 | 007 | 009 | 011 |
| Reheat / Heat - Capacity includes evaporator motor heat, (Optional) | | | | | | |
| Electric Reheat / Heat - (Optional) | | | | | | |
| Capacity | MBH (kW) | 17,670 (5.2) | 18,245 (5.3) | 18,245 (5.3) | 18,820 (5.5) | 18,820 (5.5) |
| Stages Std / (Opt.) | NO / TXT | 1 / (SCR) | 1 / (SCR) | 1 / (SCR) | 1 / (SCR) | 1 / (SCR) |
| Hot Gas Reheat - (Optional - DX Compressorized Systems Only!) | | | | | | |
| Capacity | MBH (kW) | 16.7 (4.9) | 23.2 (6.8) | 29.7 (8.7) | 36.2 (10.6) | 41.7 (12.2) |
| Control Valve | TXT | 3-Way Diverting (2-POS, ON/OFF) - Factory Installed | | | | |
| Humidification - Electrode Steam Canister Humidifier with Adjustable Output - (Optional) | | | | | | |
| Steam Canister | lb/hr (kg/hr) | 5 (2.3) | 5 (2.3) | 5 (2.3) | 5 (2.3) | 5 (2.3) |
| Power Input | kW | 1.7 | 1.7 | 1.7 | 1.7 | 1.7 |
| Evaporator Fan / Motor - Direct-Drive, Backward-Inclined EC Plug Fan Impeller (Variable Speed Adjustable for Balancing) | | | | | | |
| Std Airflow Rate | CFM (CMH) | 750 (1,274) | 1,050 (1,784) | 1,350 (2,294) | 1,650 (2,803) | 1,900 (3,228) |
| Std Blower Motor | HP (kW) | 0.14 (0.11) | 0.16 (0.12) | 0.44 (0.33) | 0.57 (0.43) | 0.76 (0.57) |
| Opt Airflow Rate | CFM (CMH) | 500 (850) | 750 (1,274) | 1000 (1,699) | 1250 (2,124) | 1600 (2,718) |
| Opt Blower Motor | HP (kW) | 0.14 (0.11) | 0.16 (0.12) | 0.44 (0.33) | 0.57 (0.43) | 0.76 (0.57) |
| E.S.P. (UP-FLOW) | IN WG | 0.30 | 0.30 | 0.30 | 0.30 | 0.30 |
| E.S.P. (DOWN-FLOW) | IN WG | 0.20 | 0.20 | 0.20 | 0.20 | 0.20 |
| Evaporator Coil - Aluminum Fin, Copper Tube | | | | | | |
| DX Coil Rows / Face Area | NO / FT2 (m2) | 3 / 3.23 (0.30) | 3 / 3.23 (0.30) | 4 / 3.23 (0.30) | 4 / 3.23 (0.30) | 4 / 3.23 (0.30) |
| CW Coil Rows / Face Area | NO / FT2 (m2) | 3 / 3.23 (0.30) | 3 / 3.23 (0.30) | 3 / 3.23 (0.30) | 4 / 3.23 (0.30) | 4 / 3.23 (0.30) |
| Face Velocity (Std Airflow) | FPM (m/s) | 240 (1.22) | 336 (1.71) | 432 (2.19) | 528 (2.68) | 608 (3.09) |
| Face Velocity (Opt Airflow) | FPM (m/s) | 160 (0.81) | 240 (1.22) | 320 (1.63) | 400 (2.03) | 512 (2.6) |
| Filters - 2 in (51 mm), Merv-8 Efficient (... Optional Merv-11 or Merv-13 Filters Also Available) | | | | | | |
| Nom. Size (UP-FLOW) | IN (mm) | 18x24 (457x610) | 18x24 (457x610) | 18x24 (457x610) | 18x24 (457x610) | 18x24 (457x610) |
| Nom. Size (DOWN-FLOW) | IN (mm) | 18x24 (457x610) | 18x24 (457x610) | 18x24 (457x610) | 18x24 (457x610) | 18x24 (457x610) |
| Quantity | NO | One | One | One | One | One |
| Compressor - High Efficiency, Fixed Speed Scroll Standard | | | | | | |
| Type (Qty.) | TXT (NO) | Scroll (One) | Scroll (One) | Scroll (One) | Scroll (One) | Scroll (One) |
| 2-Speed or Digital Scroll | TXT | 2-Spd Optional | 2-Spd Optional | 2-Spd Optional | 2-Spd Optional | 2-Spd or Digital Opt |
| Refrigerant Charge - Base Unit w/o Receiver or Hot Gas Reheat Coil (consult factory for these values) | | | | | | |
| DX - Air Cooled | lb (kg) | 8.7 (4.0) | 7.5 (3.4) | 8.3 (3.8) | 10.1 (4.6) | 12.3 (5.6) |
| DX - Water Cooled | lb (kg) | 2.2 (1.0) | 2.4 (1.1) | 2.4 (1.1) | 2.4 (1.1) | 2.6 (1.2) |
| DX - Glycol Cooled | lb (kg) | 2.2 (1.0) | 2.4 (1.1) | 2.4 (1.1) | 2.4 (1.1) | 2.6 (1.2) |
| Connection Sizes | | | | | | |
| Cond. Drain w/ Pump | OD IN | 1/2 | 1/2 | 1/2 | 1/2 | 1/2 |
| Cond. Drain w/o Pump | PVC FPT IN | 3/4 | 3/4 | 3/4 | 3/4 | 3/4 |
| Humidifier Inlet | OD IN | 1/4 | 1/4 | 1/4 | 1/4 | 1/4 |
| DX Refrig & W/G Condenser | TXT | See Page for Table on Page 14 for Split DX Refrigerant & Water/Glycol Condenser Piping Connections | | | | |
| Chilled Water IN/OUT | OD IN | 5/8 | 5/8 | 7/8 | 7/8 | 7/8 |
| Dimensions - (Overall Nominal, For more information see detailed dimensional drawing section) | | | | | | |
| MC_UF (w/o Plenum, HxWxL) | IN (mm) | 76x24x24 (11930.4x609.6x609.6) | 76x24x24 (11930.4x609.6x609.6) | 76x24x24 (11930.4x609.6x609.6) | 76x24x24 (11930.4x609.6x609.6) | 76x24x24 (11930.4x609.6x609.6) |
| MC_UF (w/ Plenum, HxWxL) | IN (mm) | 91.5x24x24 (2324.1x609.6x609.6) | 91.5x24x24 (2324.1x609.6x609.6) | 91.5x24x24 (2324.1x609.6x609.6) | 91.5x24x24 (2324.1x609.6x609.6) | 91.5x24x24 (2324.1x609.6x609.6) |
| MC_DF (HxWxL) | IN (mm) | 81x24x24 (2057.4x609.6x609.6) | 81x24x24 (2057.4x609.6x609.6) | 81x24x24 (2057.4x609.6x609.6) | 81x24x24 (2057.4x609.6x609.6) | 81x24x24 (2057.4x609.6x609.6) |
| Weight - (Approx. - Typical Standard unit w/ Steam Humid, 5 KW RH/HT, Condensate Pump) | | | | | | |
| MCE-* | LBS (kg) | 450 (204) | 450 (204) | 450 (204) | 460 (209) | 460 (209) |
| MCH-* | LBS (kg) | 400 (181) | 400 (181) | 400 (181) | 410 (186) | 410 (186) |
| MCW or MCG-* | LBS (kg) | 480 (218) | 480 (218) | 480 (218) | 500 (227) | 500 (227) |
| MCC-* | LBS (kg) | 400 (181) | 400 (181) | 400 (181) | 410 (186) | 410 (186) |
| Plenum Box | LBS (kg) | 35 (16) | 35 (16) | 35 (16) | 35 (16) | 35 (16) |
| Shipping Pallet (add to above) | LBS (kg) | 70 (32) | 70 (32) | 70 (32) | 70 (32) | 70 (32) |

ALL SYSTEMS

ELECTRICAL COMPONENT DATA - MC2x2

| Unit Size (Tons) | MC2x2 Model | Main Power Supply | Compressor (Fixed Speed) | | | | Evap Fan Motor | | | | Electric Reheat/Heat (Optional) | | Steam Humidifier (Optional) | | |
|------------------|--------------|-------------------|--------------------------|------|-------|--------|----------------|-----|-------------|------|---------------------------------|------|-----------------------------|-----|-----|
| | | | Qty. | RLA | LRA | Type | Qty. | FLA | HP (kW) | Type | KW | FLA | LB/HR (kg/hr) | FLA | KW |
| 4kW (1.0 Ton) | MC_-004S-1-* | 208/1/60 | 1 | 9.0 | 46.0 | Scroll | 1 | 4.9 | 0.14 (0.11) | EC | 5.01 | 24.1 | 5 (2.3) | 8.2 | 1.7 |
| | MC_-004S-7-* | 277/1/60 | 1 | 6.7 | 34.5 | Scroll | 1 | 3.7 | 0.14 (0.11) | EC | 5.01 | 18.1 | 5 (2.3) | 6.2 | 1.7 |
| 5kW (1.5 Tons) | MC_-005S-1-* | 208/1/60 | 1 | 12.8 | 58.3 | Scroll | 1 | 4.9 | 0.44 (0.33) | EC | 5.01 | 24.1 | 5 (2.3) | 8.2 | 1.7 |
| | MC_-005S-7-* | 277/1/60 | 1 | 9.6 | 54.0 | Scroll | 1 | 3.7 | 0.44 (0.33) | EC | 5.01 | 18.1 | 5 (2.3) | 6.2 | 1.7 |
| | MC_-005S-3-* | 208/3/60 | 1 | 7.7 | 55.4 | Scroll | 1 | 4.5 | 0.44 (0.33) | EC | 5.01 | 13.9 | 5 (2.3) | 8.2 | 1.7 |
| | MC_-005S-4-* | 460/3/60 | 1 | 3.6 | 28.0 | Scroll | 1 | 2.2 | 0.44 (0.33) | EC | 5.01 | 6.3 | 5 (2.3) | 3.7 | 1.7 |
| 7kW (2.0 Tons) | MC_-007S-1-* | 208/1/60 | 1 | 12.8 | 64.0 | Scroll | 1 | 4.9 | 0.44 (0.33) | EC | 5.01 | 24.1 | 5 (2.3) | 8.2 | 1.7 |
| | MC_-007S-7-* | 277/1/60 | 1 | 10.9 | 60.0 | Scroll | 1 | 3.7 | 0.44 (0.33) | EC | 5.01 | 18.1 | 5 (2.3) | 6.2 | 1.7 |
| | MC_-007S-3-* | 208/3/60 | 1 | 8.3 | 58.0 | Scroll | 1 | 4.5 | 0.44 (0.33) | EC | 5.01 | 13.9 | 5 (2.3) | 8.2 | 1.7 |
| | MC_-007S-4-* | 460/3/60 | 1 | 5.1 | 28.0 | Scroll | 1 | 2.2 | 0.44 (0.33) | EC | 5.01 | 6.3 | 5 (2.3) | 3.7 | 1.7 |
| 9kW (2.5 Tons) | MC_-009S-1-* | 208/1/60 | 1 | 16.7 | 79.0 | Scroll | 1 | 4.9 | 0.57 (0.43) | EC | 5.01 | 24.1 | 5 (2.3) | 8.2 | 1.7 |
| | MC_-009S-7-* | 277/1/60 | 1 | 13.5 | 72.0 | Scroll | 1 | 3.7 | 0.57 (0.43) | EC | 5.01 | 18.1 | 5 (2.3) | 6.2 | 1.7 |
| | MC_-009S-3-* | 208/3/60 | 1 | 10.4 | 73.0 | Scroll | 1 | 4.5 | 0.57 (0.43) | EC | 5.01 | 13.9 | 5 (2.3) | 8.2 | 1.7 |
| | MC_-009S-4-* | 460/3/60 | 1 | 5.8 | 38.0 | Scroll | 1 | 2.2 | 0.57 (0.43) | EC | 5.01 | 6.3 | 5 (2.3) | 3.7 | 1.7 |
| 11kW (3.0 Tons) | MC_-011S-1-* | 208/1/60 | 1 | 17.9 | 112.0 | Scroll | 1 | 4.9 | 0.76 (0.57) | EC | 5.01 | 24.1 | 5 (2.3) | 8.2 | 1.7 |
| | MC_-011S-7-* | 277/1/60 | 1 | 16.0 | 87.0 | Scroll | 1 | 3.7 | 0.76 (0.57) | EC | 5.01 | 18.1 | 5 (2.3) | 6.2 | 1.7 |
| | MC_-011S-3-* | 208/3/60 | 1 | 13.5 | 88.0 | Scroll | 1 | 4.5 | 0.76 (0.57) | EC | 5.01 | 13.9 | 5 (2.3) | 8.2 | 1.7 |
| | MC_-011S-4-* | 460/3/60 | 1 | 6.0 | 44.0 | Scroll | 1 | 2.2 | 0.76 (0.57) | EC | 5.01 | 6.3 | 5 (2.3) | 3.7 | 1.7 |

DX - DX Split Evap & Water/Glycol Cooled Self-Contained

| MODEL | MCE, MCW & MCG-004 | | MCE, MCW & MCG-005 | | MCE, MCW & MCG-007 | | | | MCE, MCW & MCG-009 | | | | MCE, MCW & MCG-011 | | | |
|--|--------------------|----------|--------------------|----------|--------------------|----------|----------|----------|--------------------|----------|----------|----------|--------------------|----------|----------|----------|
| Power Supply | 208/1/60 | 277/1/60 | 208/1/60 | 277/1/60 | 208/1/60 | 277/1/60 | 208/3/60 | 460/3/60 | 208/1/60 | 277/1/60 | 208/3/60 | 460/3/60 | 208/1/60 | 277/1/60 | 208/3/60 | 460/3/60 |
| Cooling Only (or Cooling with Hot Gas Reheat, Hot Water or Steam Reheat/Heat) | | | | | | | | | | | | | | | | |
| FLA | 13.9 | 10.8 | 17.7 | 13.3 | 17.7 | 14.6 | 12.9 | 7.3 | 21.5 | 17.1 | 15.0 | 7.9 | 22.8 | 19.7 | 18.1 | 8.1 |
| MCA | 16.1 | 12.5 | 20.9 | 15.7 | 20.9 | 17.3 | 15.0 | 8.6 | 25.7 | 20.5 | 17.6 | 9.4 | 27.3 | 23.7 | 21.4 | 9.6 |
| MOP | 25 | 15 | 30 | 25 | 30 | 25 | 20 | 15 | 40 | 30 | 25 | 15 | 45 | 35 | 30 | 15 |
| with Electric Heat (No Electric Reheat or Humidifier) | | | | | | | | | | | | | | | | |
| FLA | 29.0 | 21.7 | 29.0 | 21.7 | 29.0 | 21.7 | 18.4 | 8.4 | 29.0 | 21.7 | 18.4 | 8.4 | 29.0 | 21.7 | 18.4 | 8.4 |
| MCA | 36.2 | 27.2 | 36.2 | 27.2 | 36.2 | 27.2 | 23.1 | 10.6 | 36.2 | 27.2 | 23.1 | 10.6 | 36.2 | 27.2 | 23.1 | 10.6 |
| MOP | 40 | 30 | 40 | 30 | 40 | 30 | 25 | 15 | 40 | 30 | 25 | 15 | 45 | 35 | 30 | 15 |
| with Electric Reheat/Heat (No Humidifier) | | | | | | | | | | | | | | | | |
| FLA | 38.0 | 28.8 | 41.8 | 31.4 | 41.8 | 32.6 | 26.8 | 13.6 | 45.6 | 35.2 | 28.9 | 14.2 | 46.9 | 37.8 | 32.0 | 14.4 |
| MCA | 46.2 | 35.1 | 51.0 | 38.3 | 51.0 | 39.9 | 32.3 | 16.4 | 55.8 | 43.1 | 35.0 | 17.2 | 57.4 | 46.3 | 38.8 | 17.5 |
| MOP | 50 | 40 | 60 | 40 | 60 | 45 | 35 | 20 | 60 | 50 | 40 | 20 | 60 | 50 | 45 | 20 |
| with Humidifier with or without Hot Gas Reheat, Hot Water/Steam Reheat/Heat (No Electric Reheat/Heat) | | | | | | | | | | | | | | | | |
| FLA | 22.1 | 17.0 | 25.9 | 19.5 | 25.9 | 20.8 | 21.1 | 11.0 | 29.7 | 23.3 | 23.2 | 11.6 | 31.0 | 25.9 | 26.3 | 11.8 |
| MCA | 24.3 | 18.7 | 29.1 | 21.9 | 29.1 | 23.5 | 23.2 | 12.3 | 33.9 | 26.7 | 25.8 | 13.1 | 35.5 | 29.9 | 29.6 | 13.3 |
| MOP | 30 | 25 | 40 | 30 | 40 | 30 | 30 | 15 | 50 | 40 | 35 | 15 | 50 | 45 | 40 | 15 |
| with Electric Heat (No Electric Reheat) & Humidifier | | | | | | | | | | | | | | | | |
| FLA | 37.2 | 27.9 | 37.2 | 27.9 | 37.2 | 27.9 | 26.6 | 12.1 | 37.2 | 27.9 | 26.6 | 12.1 | 37.2 | 27.9 | 26.6 | 12.1 |
| MCA | 44.4 | 33.4 | 44.4 | 33.4 | 44.4 | 33.4 | 31.3 | 14.3 | 44.4 | 33.4 | 31.3 | 14.3 | 44.4 | 33.4 | 31.3 | 14.3 |
| MOP | 45 | 35 | 45 | 35 | 45 | 35 | 35 | 15 | 50 | 40 | 35 | 15 | 50 | 45 | 40 | 15 |
| with Electric Reheat/Heat & Humidifier | | | | | | | | | | | | | | | | |
| FLA | 38.0 | 28.8 | 41.8 | 31.4 | 41.8 | 32.6 | 26.8 | 13.6 | 45.6 | 35.2 | 28.9 | 14.2 | 46.9 | 37.8 | 32.0 | 14.4 |
| MCA | 46.2 | 35.1 | 51.0 | 38.3 | 51.0 | 39.9 | 32.3 | 16.4 | 55.8 | 43.1 | 35.0 | 17.2 | 57.4 | 46.3 | 38.8 | 17.5 |
| MOP | 50 | 40 | 60 | 40 | 60 | 45 | 35 | 20 | 60 | 50 | 40 | 20 | 60 | 50 | 45 | 20 |

DX Split and Chilled Water - Air Handling Units

| MODEL | MCC & MCH-004, 005, 007, 009 & 011 | | | |
|--|------------------------------------|----------|----------|----------|
| Power Supply | 208/1/60 | 277/1/60 | 208/3/60 | 460/3/60 |
| Cooling Only (or Cooling with Hot Water or Steam Reheat/Heat) | | | | |
| FLA | 4.9 | 3.7 | 4.5 | 2.2 |
| MCA | 6.1 | 4.6 | 5.7 | 2.7 |
| MOP | 15 | 15 | 15 | 15 |
| with Electric Heat or Reheat/Heat (No Humidifier) | | | | |
| FLA | 29.0 | 21.7 | 18.4 | 8.4 |
| MCA | 36.2 | 27.2 | 23.1 | 10.6 |
| MOP | 40 | 30 | 25 | 15 |
| with Electric Reheat/Heat (No Humidification) | | | | |
| FLA | 29.0 | 21.7 | 18.4 | 8.4 |
| MCA | 36.2 | 27.2 | 23.1 | 10.6 |
| MOP | 40 | 30 | 25 | 15 |
| with Humidifier with or without Hot Water/Steam Reheat/Heat (No Electric Reheat/Heat) | | | | |
| FLA | 13.1 | 9.9 | 12.7 | 5.9 |
| MCA | 14.3 | 10.8 | 13.9 | 6.4 |
| MOP | 15 | 15 | 15 | 15 |
| with Electric Heat (No Electric Reheat) & Humidifier | | | | |
| FLA | 37.2 | 27.9 | 26.6 | 12.1 |
| MCA | 44.4 | 33.4 | 31.3 | 14.3 |
| MOP | 45 | 35 | 35 | 15 |
| with Electric Heat or Electric Reheat/Heat & Humidifier | | | | |
| FLA | 37.2 | 27.9 | 26.6 | 12.1 |
| MCA | 44.4 | 33.4 | 31.3 | 14.3 |
| MOP | 45 | 35 | 35 | 15 |

Notes:

- 1) FLA = Full Load Amps; MCA = Min Circuit Amps; MOP = Max Overcurrent Protection (Max Fuse Size)
- 2) 277/1/60 systems may require factory provided field installed step-down transformer.
- 3) - - - - Consult local AboveAir Sales Representative for non-cataloged system power supply information.

DX - AIR & WATER / GLYCOL COOLED REMOTE CONDENSERS & CONDENSING UNITS

| Unit Size (Nominal) | Condenser / Cond Unit Model | Main Power Supply | Type | Compressor (Fixed Speed) | | | | Cond Fan Motor | | | | Unit Nameplate Data | | |
|---------------------|-----------------------------|--------------------|----------------------|--------------------------|------|--------|--------|----------------|------------|-----|------|---------------------|------|-----|
| | | | | Qty. | RLA | LRA | Type | Qty. | HP (kW) | FLA | Type | FLA | MCA | MOP |
| 4kW (1.0 Ton) | XP1-012S-1* | 208/1/60 | Outdoor Pad/Roof Mtd | --- | --- | --- | --- | 1 | 1/6 (0.12) | 1.1 | PSC | 1.1 | 1.4 | 15 |
| | XP1-012S-7* | 277/1/60 | Outdoor Pad/Roof Mtd | --- | --- | --- | --- | 1 | 1/6 (0.12) | 0.8 | PSC | 0.8 | 1.0 | 15 |
| | XPU-004S-1* | 208/1/60 | Outdoor Pad/Roof Mtd | 1 | 9.0 | 48.0 | Scroll | 1 | 1/6 (0.12) | 1.1 | PSC | 10.1 | 12.4 | 20 |
| | XPU-004S-7* | 277/1/60 | Outdoor Pad/Roof Mtd | 1 | 7.1 | 43.0 | Scroll | 1 | 1/6 (0.12) | 0.8 | PSC | 7.9 | 9.7 | 15 |
| | CCX-004S-1* | 208/1/60 | Indoor Ceiling Mtd | --- | --- | --- | --- | 1 | 1/2 (0.37) | 4.0 | PSC | 4.0 | 5.0 | 15 |
| | CCX-004S-7* | 277/1/60 | Indoor Ceiling Mtd | --- | --- | --- | --- | 1 | 1/2 (0.37) | 2.2 | PSC | 2.2 | 2.8 | 15 |
| | CCU-004S-1* | 208/1/60 | Indoor Ceiling Mtd | 1 | 9.0 | 48.0 | Scroll | 1 | 1/2 (0.37) | 4.0 | PSC | 13.0 | 15.3 | 20 |
| | CCU-004S-7* | 277/1/60 | Indoor Ceiling Mtd | 1 | 7.1 | 43.0 | Scroll | 1 | 1/2 (0.37) | 2.2 | PSC | 9.3 | 11.1 | 15 |
| | CWU/CGU-004S-1* | 208/1/60 | Indoor Ceiling Mtd | 1 | 9.0 | 48.0 | Scroll | --- | --- | --- | --- | 9.0 | 11.3 | 20 |
| | CWU/CGU-004S-7* | 277/1/60 | Indoor Ceiling Mtd | 1 | 7.1 | 43.0 | Scroll | --- | --- | --- | --- | 7.1 | 8.9 | 15 |
| 5kW (1.5 Tons) | XP1-018S-1* | 208/1/60 | Outdoor Pad/Roof Mtd | --- | --- | --- | --- | 1 | 1/6 (0.12) | 1.1 | PSC | 1.1 | 1.4 | 15 |
| | XP1-018S-7* | 277/1/60 | Outdoor Pad/Roof Mtd | --- | --- | --- | --- | 1 | 1/6 (0.12) | 0.8 | PSC | 0.8 | 1.0 | 15 |
| | XPU-005S-1* | 208/1/60 | Outdoor Pad/Roof Mtd | 1 | 9.0 | 48.0 | Scroll | 1 | 1/6 (0.12) | 1.1 | PSC | 10.1 | 12.4 | 20 |
| | XPU-005S-7* | 277/1/60 | Outdoor Pad/Roof Mtd | 1 | 7.1 | 43.0 | Scroll | 1 | 1/6 (0.12) | 0.8 | PSC | 7.9 | 9.7 | 15 |
| | CCX-005S-1* | 208/1/60 | Indoor Ceiling Mtd | --- | --- | --- | --- | 1 | 1/2 (0.37) | 4.0 | PSC | 4.0 | 5.0 | 15 |
| | CCX-005S-7* | 277/1/60 | Indoor Ceiling Mtd | --- | --- | --- | --- | 1 | 1/2 (0.37) | 2.2 | PSC | 2.2 | 2.8 | 15 |
| | CCU-005S-1* | 208/1/60 | Indoor Ceiling Mtd | 1 | 9.0 | 48.0 | Scroll | 1 | 1/2 (0.37) | 4.0 | PSC | 13.0 | 15.3 | 20 |
| | CCU-005S-7* | 277/1/60 | Indoor Ceiling Mtd | 1 | 7.1 | 43.0 | Scroll | 1 | 1/2 (0.37) | 2.2 | PSC | 9.3 | 11.1 | 15 |
| | CWU/CGU-005S-1* | 208/1/60 | Indoor Ceiling Mtd | 1 | 9.0 | 48.0 | Scroll | --- | --- | --- | --- | 9.0 | 11.3 | 20 |
| | CWU/CGU-005S-7* | 277/1/60 | Indoor Ceiling Mtd | 1 | 7.1 | 43.0 | Scroll | --- | --- | --- | --- | 7.1 | 8.9 | 15 |
| 7kW (2.0 Tons) | XP1-024S-1* | 208/1/60 | Outdoor Pad/Roof Mtd | --- | --- | --- | --- | 1 | 1/6 (0.12) | 1.1 | PSC | 1.1 | 1.4 | 15 |
| | XP1-024S-7* | 277/1/60 | Outdoor Pad/Roof Mtd | --- | --- | --- | --- | 1 | 1/6 (0.12) | 0.8 | PSC | 0.8 | 1.0 | 15 |
| | XP1-024S-3* | 208/3/60 | N/A | | | | | | | | | | | |
| | XP1-024S-8* | 460/1/60 | Outdoor Pad/Roof Mtd | --- | --- | --- | --- | 1 | 1/4 (0.19) | 1.0 | PSC | 1.0 | 1.3 | 15 |
| | XPU-007S-1* | 208/1/60 | Outdoor Pad/Roof Mtd | 1 | 10.9 | 62.9 | Scroll | 1 | 1/6 (0.12) | 1.1 | PSC | 12.0 | 14.7 | 25 |
| | XPU-007S-7* | 277/1/60 | Outdoor Pad/Roof Mtd | 1 | 8.2 | 47.2 | Scroll | 1 | 1/6 (0.12) | 0.8 | PSC | 9.0 | 11.1 | 15 |
| | XPU-007S-3* | 208/3/60 | Outdoor Pad/Roof Mtd | 1 | 7.7 | 55.4 | Scroll | 1 | 1/6 (0.12) | 1.1 | PSC | 8.8 | 10.7 | 15 |
| | XPU-007S-4* | 460/3/60 | Outdoor Pad/Roof Mtd | 1 | 3.6 | 28.0 | Scroll | 1 | 1/4 (0.19) | 1.0 | PSC | 4.6 | 5.5 | 15 |
| | CCX-007S-1* | 208/1/60 | Indoor Ceiling Mtd | --- | --- | --- | --- | 1 | 3/4 (0.56) | 5.4 | PSC | 5.4 | 6.8 | 15 |
| | CCX-007S-7* | 277/1/60 | Indoor Ceiling Mtd | --- | --- | --- | --- | 1 | 3/4 (0.56) | 3.9 | PSC | 3.9 | 4.9 | 15 |
| | CCX-007S-3* | 208/3/60 | N/A | | | | | | | | | | | |
| | CCX-007S-8* | 460/1/60 | Indoor Ceiling Mtd | --- | --- | --- | --- | 1 | 3/4 (0.56) | 2.8 | PSC | 2.8 | 3.5 | 15 |
| | CCU-007S-1* | 208/1/60 | Indoor Ceiling Mtd | 1 | 12.8 | 58.3 | Scroll | 1 | 3/4 (0.56) | 5.4 | PSC | 18.2 | 21.4 | 30 |
| | CCU-007S-7* | 277/1/60 | Indoor Ceiling Mtd | 1 | 9.6 | 54.0 | Scroll | 1 | 3/4 (0.56) | 3.9 | PSC | 13.5 | 15.9 | 25 |
| | CCU-007S-3* | 208/3/60 | Indoor Ceiling Mtd | 1 | 7.7 | 55.4 | Scroll | 1 | 3/4 (0.56) | 5.4 | PSC | 13.1 | 15.0 | 20 |
| | CCU-007S-3* | 460/3/60 | Indoor Ceiling Mtd | 1 | 3.6 | 28.0 | Scroll | 1 | 3/4 (0.56) | 2.8 | PSC | 6.4 | 7.3 | 15 |
| | CWU/CGU-007S-1* | 208/1/60 | Indoor Ceiling Mtd | 1 | 12.8 | 58.3 | Scroll | --- | --- | --- | --- | 12.8 | 16.0 | 25 |
| | CWU/CGU-007S-7* | 277/1/60 | Indoor Ceiling Mtd | 1 | 10.9 | 60.0 | Scroll | --- | --- | --- | --- | 10.9 | 13.6 | 20 |
| CWU/CGU-007S-3* | 208/3/60 | Indoor Ceiling Mtd | 1 | 7.7 | 55.4 | Scroll | --- | --- | --- | --- | 7.7 | 9.6 | 15 | |
| CWU/CGU-007S-4* | 460/3/60 | Indoor Ceiling Mtd | 1 | 3.6 | 28.0 | Scroll | --- | --- | --- | --- | 3.6 | 4.5 | 15 | |

Notes:

- 1) FLA = Full Load Amps; MCA = Min Circuit Amps; MOP = Max Overcurrent Protection (Max Fuse Size)
- 2) 277/1/60 systems may require factory provided field installed step-down transformer.
- 3) --- Consult local AboveAir Sales Representative for non-cataloged system power supply information.

DX - AIR & WATER / GLYCOL COOLED REMOTE CONDENSERS & CONDENSING UNITS ... Continued from Page 19

| Unit Size (Nominal) | Condenser / Cond Unit Model | Main Power Supply | Type | Compressor (Fixed Speed) | | | | Cond Fan Motor | | | | Unit Nameplate Data | | |
|----------------------------|-----------------------------|--------------------|----------------------|--------------------------|------|--------|--------|----------------|------------|-----|------|---------------------|------|-----|
| | | | | Qty. | RLA | LRA | Type | Qty. | HP (kW) | FLA | Type | FLA | MCA | MOP |
| 9kW (2.5 Tons) | XP1-030S-1* | 208/1/60 | Outdoor Pad/Roof Mtd | --- | --- | --- | --- | 1 | 1/4 (0.19) | 2.0 | PSC | 2.0 | 2.5 | 15 |
| | XP1-030S-7* | 277/1/60 | Outdoor Pad/Roof Mtd | --- | --- | --- | --- | 1 | 1/4 (0.19) | 1.5 | PSC | 1.5 | 1.9 | 15 |
| | XP1-030S-3* | 208/3/60 | N/A | | | | | | | | | | | |
| | XP1-030S-8* | 460/1/60 | Outdoor Pad/Roof Mtd | --- | --- | --- | --- | 1 | 1/4 (0.19) | 1.0 | PSC | 1.0 | 1.3 | 15 |
| | XPU-009S-1* | 208/1/60 | Outdoor Pad/Roof Mtd | 1 | 12.8 | 64.0 | Scroll | 1 | 1/4 (0.19) | 2.0 | PSC | 14.8 | 18.0 | 30 |
| | XPU-009S-7* | 277/1/60 | Outdoor Pad/Roof Mtd | 1 | 9.6 | 48.1 | Scroll | 1 | 1/4 (0.19) | 1.5 | PSC | 11.1 | 13.5 | 20 |
| | XPU-009S-3* | 208/3/60 | Outdoor Pad/Roof Mtd | 1 | 8.3 | 58.0 | Scroll | 1 | 1/4 (0.19) | 2.0 | PSC | 10.3 | 12.4 | 20 |
| | XPU-009S-4* | 460/3/60 | Outdoor Pad/Roof Mtd | 1 | 5.1 | 28.0 | Scroll | 1 | 1/4 (0.19) | 1.0 | PSC | 6.1 | 7.4 | 15 |
| | CCX-009S-1* | 208/1/60 | Indoor Ceiling Mtd | --- | --- | --- | --- | 1 | 3/4 (0.56) | 5.4 | PSC | 5.4 | 6.8 | 15 |
| | CCX-009S-7* | 277/1/60 | Indoor Ceiling Mtd | --- | --- | --- | --- | 1 | 3/4 (0.56) | 3.9 | PSC | 3.9 | 4.9 | 15 |
| | CCX-009S-3* | 208/3/60 | N/A | | | | | | | | | | | |
| | CCX-009S-8* | 460/1/60 | Indoor Ceiling Mtd | --- | --- | --- | --- | 1 | 3/4 (0.56) | 2.8 | PSC | 2.8 | 3.5 | 15 |
| | CCU-009S-1* | 208/1/60 | Indoor Ceiling Mtd | 1 | 12.8 | 64.0 | Scroll | 1 | 3/4 (0.56) | 5.4 | PSC | 18.2 | 21.4 | 30 |
| | CCU-009S-7* | 277/1/60 | Indoor Ceiling Mtd | 1 | 10.9 | 60.0 | Scroll | 1 | 3/4 (0.56) | 3.9 | PSC | 14.8 | 17.5 | 25 |
| | CCU-009S-3* | 208/3/60 | Indoor Ceiling Mtd | 1 | 8.3 | 58.0 | Scroll | 1 | 3/4 (0.56) | 5.4 | PSC | 13.7 | 15.8 | 20 |
| | CCU-009S-4* | 460/3/60 | Indoor Ceiling Mtd | 1 | 5.1 | 28.0 | Scroll | 1 | 3/4 (0.56) | 2.8 | PSC | 7.9 | 9.2 | 15 |
| | CWU/CGU-009S-1* | 208/1/60 | Indoor Ceiling Mtd | 1 | 12.8 | 64.0 | Scroll | --- | --- | --- | --- | 12.8 | 16.0 | 25 |
| | CWU/CGU-009S-7* | 277/1/60 | Indoor Ceiling Mtd | 1 | 10.9 | 60.0 | Scroll | --- | --- | --- | --- | 10.9 | 13.6 | 20 |
| CWU/CGU-009S-3* | 208/3/60 | Indoor Ceiling Mtd | 1 | 8.3 | 58.0 | Scroll | --- | --- | --- | --- | 8.3 | 10.4 | 15 | |
| CWU/CGU-009S-4* | 460/3/60 | Indoor Ceiling Mtd | 1 | 5.1 | 28.0 | Scroll | --- | --- | --- | --- | 5.1 | 6.4 | 15 | |
| 11kW (3.0 Tons) | XP1-036S-1* | 208/1/60 | Outdoor Pad/Roof Mtd | --- | --- | --- | --- | 1 | 1/4 (0.19) | 2.0 | PSC | 2.0 | 2.5 | 15 |
| | XP1-036S-7* | 277/1/60 | Outdoor Pad/Roof Mtd | --- | --- | --- | --- | 1 | 1/4 (0.19) | 1.5 | PSC | 1.5 | 1.9 | 15 |
| | XP1-036S-3* | 208/3/60 | N/A | | | | | | | | | | | |
| | XP1-036S-8* | 460/1/60 | Outdoor Pad/Roof Mtd | --- | --- | --- | --- | 1 | 1/4 (0.19) | 1.0 | PSC | 1.0 | 1.3 | 15 |
| | XPU-011S-1* | 208/1/60 | Outdoor Pad/Roof Mtd | 1 | 16.7 | 79.0 | Scroll | 1 | 1/4 (0.19) | 2.0 | PSC | 18.7 | 22.9 | 35 |
| | XPU-011S-7* | 277/1/60 | Outdoor Pad/Roof Mtd | 1 | 12.5 | 59.3 | Scroll | 1 | 1/4 (0.19) | 1.5 | PSC | 14.0 | 17.2 | 25 |
| | XPU-011S-3* | 208/3/60 | Outdoor Pad/Roof Mtd | 1 | 10.4 | 73.0 | Scroll | 1 | 1/4 (0.19) | 2.0 | PSC | 12.4 | 15.0 | 25 |
| | XPU-011S-4* | 460/3/60 | Outdoor Pad/Roof Mtd | 1 | 5.8 | 38.0 | Scroll | 1 | 1/4 (0.19) | 1.0 | PSC | 6.8 | 8.3 | 15 |
| | CCX-011S-1* | 208/1/60 | Indoor Ceiling Mtd | --- | --- | --- | --- | 1 | 3/4 (0.56) | 5.4 | PSC | 5.4 | 6.8 | 15 |
| | CCX-011S-7* | 277/1/60 | Indoor Ceiling Mtd | --- | --- | --- | --- | 1 | 3/4 (0.56) | 3.9 | PSC | 3.9 | 4.9 | 15 |
| | CCX-011S-3* | 208/3/60 | N/A | | | | | | | | | | | |
| | CCX-011S-8* | 460/1/60 | Indoor Ceiling Mtd | --- | --- | --- | --- | 1 | 3/4 (0.56) | 2.8 | PSC | 2.8 | 3.5 | 15 |
| | CCU-011S-1* | 208/1/60 | Indoor Ceiling Mtd | 1 | 16.7 | 79.0 | Scroll | 1 | 3/4 (0.56) | 5.4 | PSC | 22.1 | 26.3 | 40 |
| | CCU-011S-7* | 277/1/60 | Indoor Ceiling Mtd | 1 | 13.5 | 72.0 | Scroll | 1 | 3/4 (0.56) | 3.9 | PSC | 17.4 | 20.8 | 30 |
| | CCU-011S-3* | 208/3/60 | Indoor Ceiling Mtd | 1 | 10.4 | 73.0 | Scroll | 1 | 3/4 (0.56) | 5.4 | PSC | 15.8 | 18.4 | 25 |
| | CCU-011S-4* | 460/3/60 | Indoor Ceiling Mtd | 1 | 5.8 | 38.0 | Scroll | 1 | 3/4 (0.56) | 2.8 | PSC | 8.6 | 10.1 | 15 |
| | CWU/CGU-011S-1* | 208/1/60 | Indoor Ceiling Mtd | 1 | 16.7 | 79.0 | Scroll | --- | --- | --- | --- | 16.7 | 20.9 | 35 |
| | CWU/CGU-011S-7* | 277/1/60 | Indoor Ceiling Mtd | 1 | 13.5 | 72.0 | Scroll | --- | --- | --- | --- | 13.5 | 16.9 | 30 |
| CWU/CGU-011S-3* | 208/3/60 | Indoor Ceiling Mtd | 1 | 10.4 | 73.0 | Scroll | --- | --- | --- | --- | 10.4 | 13.0 | 20 | |
| CWU/CGU-011S-4* | 460/3/60 | Indoor Ceiling Mtd | 1 | 5.8 | 38.0 | Scroll | --- | --- | --- | --- | 5.8 | 7.3 | 15 | |

Notes:

- 1) FLA = Full Load Amps; MCA = Min Circuit Amps; MOP = Max Overcurrent Protection (Max Fuse Size)
- 2) 277/1/60 systems may require factory provided field installed step-down transformer.
- 3) ---- Consult local AboveAir Sales Representative for non-cataloged system power supply information.

UP-FLOW: 4 to 11kW (1-3 Tons)

(MCE, MCH, MCW, MCG & MCC-004 thru 011-_-__-UF_)

100% Front Access Only
(side panels also removable)

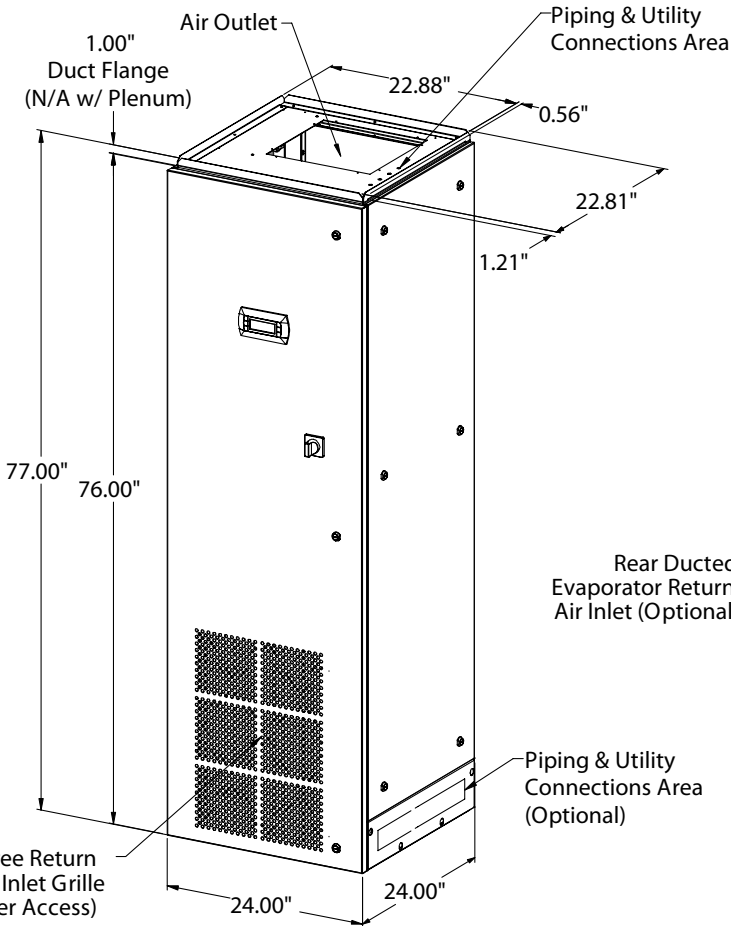
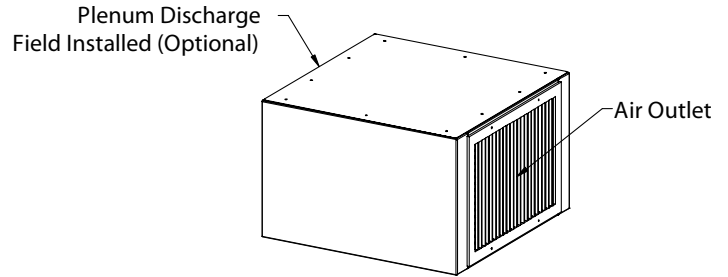
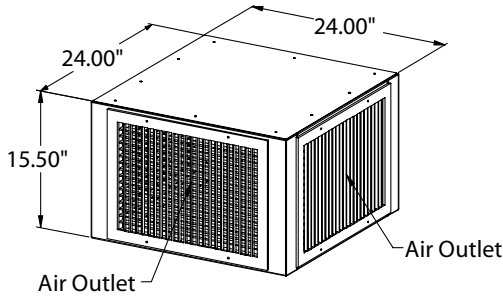

Front / Right / Top

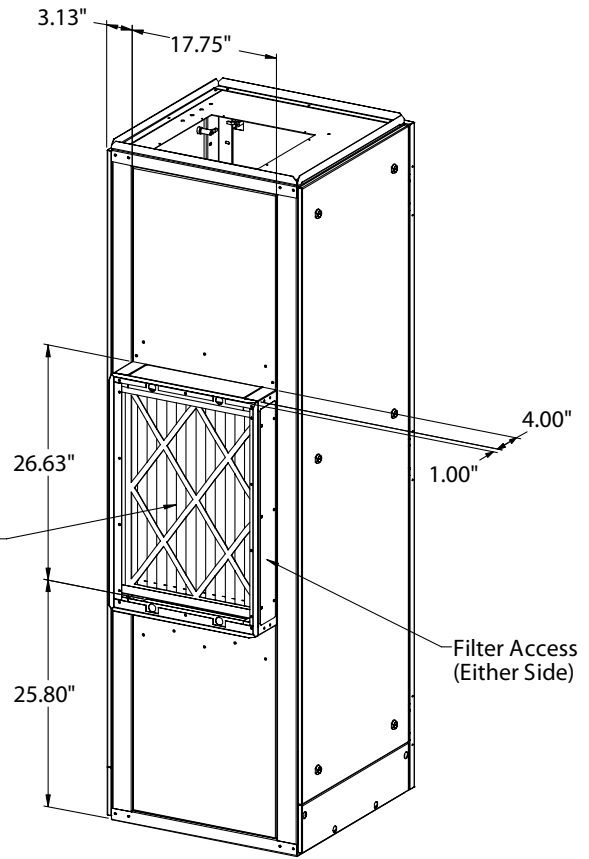

Rear / Left / Top

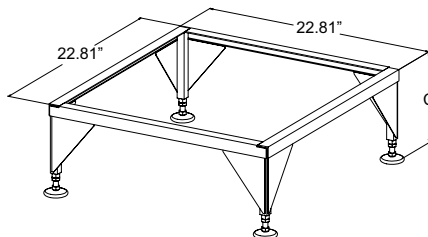

| Floor Stand Model | Nominal Height "C" |
|-------------------|----------------------------|
| FS22-04 | 4.0" (3.75"-4.75" Adj.) |
| FS22-05 | 5.0" (4.25"-5.38" Adj.) |
| FS22-06 | 6.0" (5.25"-8.25" Adj.) |
| FS22-09 | 9.0" (8.25"-11.25" Adj.) |
| FS22-12 | 12.0" (11.25"-14.25" Adj.) |
| FS22-15 | 15.0" (14.25"-17.25" Adj.) |
| FS22-18 | 18.0" (17.25"-20.25" Adj.) |
| FS22-24 | 24.0" (23.25"-26.25" Adj.) |

Dimensional Data

DOWN-FLOW: 4 to 11kW (1-3 Tons)

(MCE, MCH, MCW, MCG & MCC-004 thru 011-_-_-DF_)

100% Front Access Only
(side panels also removable)

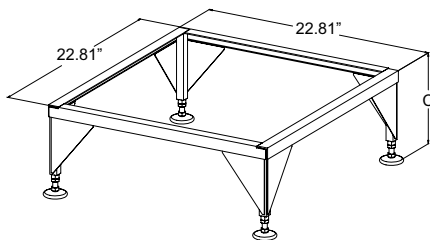
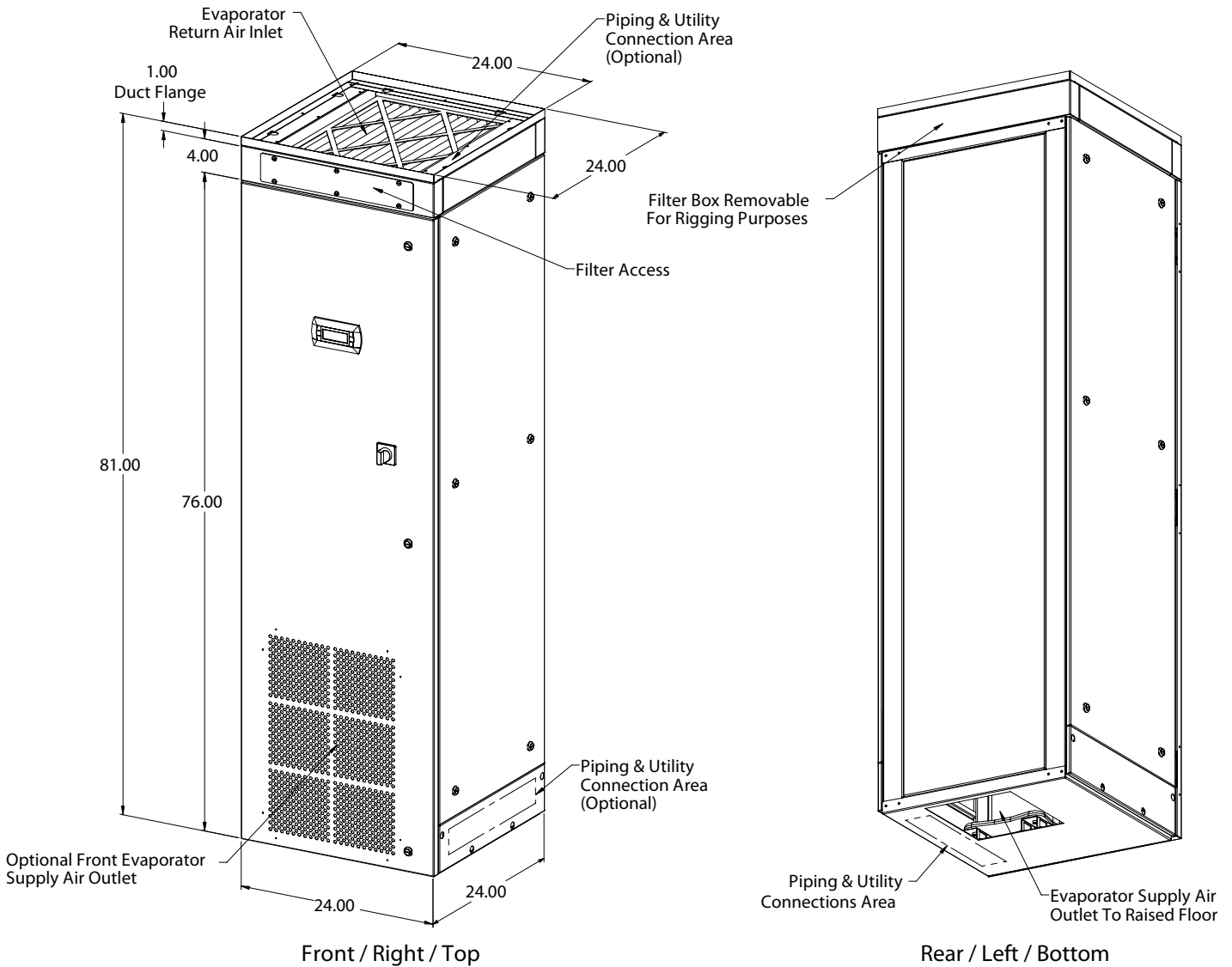

| Floor Stand Model | Nominal Height "C" |
|-------------------|----------------------------|
| FS22-06 | 6.0" (5.25"-8.25" Adj.) |
| FS22-09 | 9.0" (8.25"-11.25" Adj.) |
| FS22-12 | 12.0" (11.25"-14.25" Adj.) |
| FS22-15 | 15.0" (14.25"-17.25" Adj.) |
| FS22-18 | 18.0" (17.25"-20.25" Adj.) |
| FS22-24 | 24.0" (23.25"-26.25" Adj.) |

Note: Turning Vanes, Seismic Rated and Custom Height Floor Stands are optionally available.

Dimensional Data - Remote Air Cooled Condensers

4-11kW (1-3T), Outdoor, DX - Air Cooled Propeller Fan, Remote Condensing Units & Condensers Models: XPU & XP1-004 thru 011

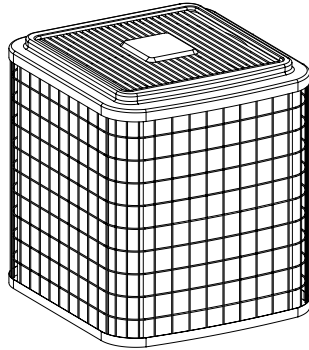

FRONT / LEFT / TOP

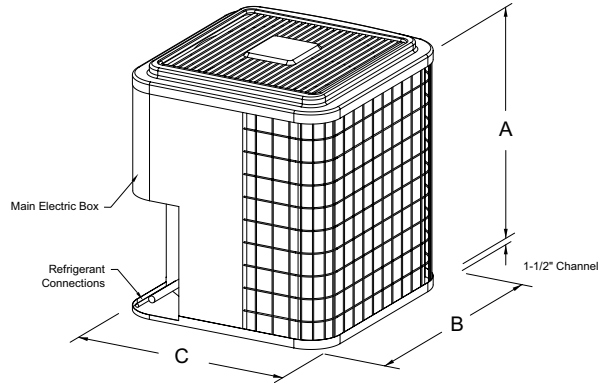

REAR / LEFT / TOP

| XP1 & XPU-() Model No. | Unit Size (Nominal) | DIMENSIONS (inches) | | |
|----------------------------|------------------------|---------------------|---------|---------|
| | | A | B | C |
| XP1/XPU-004 | 4kW (1T) | 24-13/16 | 23-1/8 | 23-1/8 |
| XP1/XPU-005 | 5kW (1.5T) | 25 | 25-3/4 | 25-3/4 |
| XP1/XPU-007 | 7kW (2T) | 28-11/16 | 23-1/8 | 23-1/8 |
| XP1/XPU-009 | 9kW (2.5T) | 31-3/16 | 25-3/4 | 25-3/4 |
| XP1/XPU-011 | 11kW (3T) | 32-5/16 | 31-3/16 | 31-3/16 |

4-11kW (1-3 Tons), Indoor Ceiling Mounted, Remote Centrifugal Blower DX - Air Cooled Condensing Units & Condensers “Same-Face (standard) or Optional Straight-Thru & “90° L” Air Patterns” Models: CCU & CCX-005 thru 011

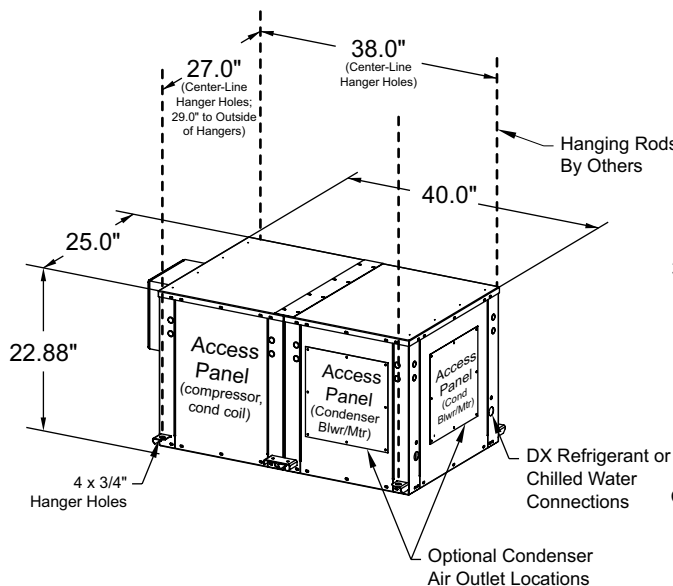

Front / Right / Top

3-Side Access:
18"-24" on Front, Left & Right Sides!

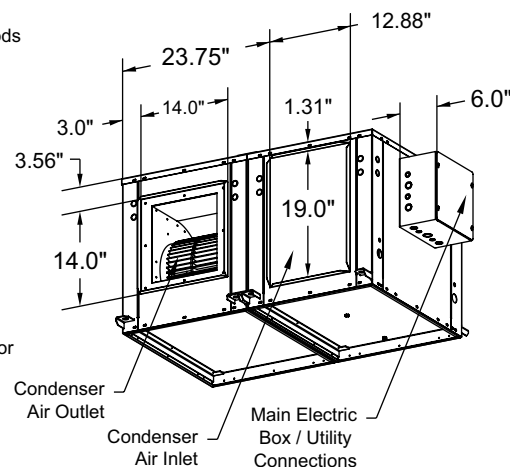

Rear / Left / Bottom

Dimensional Data

Innovative HVAC Solutions

MissionCritical Units - Precision A/C's



**SC-2x4 SpotCool
Ceiling Mounted A/C's**
(4-11kW, 1-3 Tons)



**HK Horizontal Ducted
Ceiling Mounted A/C's**
(4-70kW, 1-20 Tons)



**MC Vertical Floor Mtd A/C's
Up-Flow & Down-Flow**
(4-1080kW, 1-307 Tons)



**WC Wall-Cassette and
FC Floor-Console Mtd A/C's**
(4-18kW, 1-5 Tons)

Outdoor-Air Units - IAQ High Percent (20%-100% OA)



HK-OA Horizontal Ceiling Mtd
(1-30 Tons)



VK-OA Vertical Floor Mtd
(1-50 Tons)

Specialty Units - A/C's & Water Source Heat Pumps



**SC-2x4 SpotCool
Ceiling Mtd A/C's**
(4-11kW, 1-3 Tons)



**HK Horizontal Packaged
& Split Ceiling Mtd A/C's**
(4-70kW, 1-20 Tons)



**VK Vertical Packaged &
Split Floor Mtd A/C's**
(4-105kW, 1-30 Tons)

Remote Heat Rejection Units



**Remote Air Cooled
Condensers, Condensing Units &
Glycol Drycoolers**

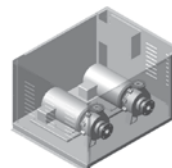

**Single, Dual & Triplex
Glycol Pump Packages**
(1/2 to 50 HP, VFD Optional)